

1915 CATALOGUE BAND INSTRUMENTS



Sherman,  Clay & Co.

KEARNY & SUTTER STS.

SAN FRANCISCO

Dealers in Musical Merchandise of Every Description

ML 155

1915

COPYRIGHT 1914 BY SHERMAN, CLAY & CO.

If You Do Not Find In This Catalogue Information Regarding the
Instruments or Goods in Which You Are Interested,
Send a Postal Request for Our

1915 General Catalogue *for Musicians*

Containing Descriptions and Illustrations of Our
Complete Assortment of

Banjos, Banjo-Mandolins, Guitars, Guitar-
Mandolins, Mandolins, Mandolas, Ukuleles,
Violins, Violas, Violoncellos, Double Basses,
Together With Their Cases, Strings and
Accessories of Every Description

AS WELL AS

Accordions, Concertinas, Harmonicas, Zithers of All Kinds, Music Wrappers
and Bags, Toy Pianos, Music Boxes, Metronomes, and
Musical Merchandise of Every Character

We Also Issue Numerous Catalogues of

*Pianos, Organs, Player Pianos and Player Music, Talking
Machines and Records, Sheet Music and Music Books,
Band and Orchestra Music*

Any of Which Will be Mailed Free Upon Receipt of Postal Card Request

A Catalogue for Band Musicians

BEING A GUIDE TO PURCHASERS OF

Band Instruments

of Every Description

INCLUDING

Clarinets, Saxophones, Flutes, Piccolos, Bassoons,
Oboes, Drums

AND EVERYTHING NECESSARY FOR THE EQUIPMENT OF

Bands and Drum Corps

WITH EXPLANATION OF OUR OFFER OF

FREE TRIAL ON ALL INSTRUMENTS AND EASY MONTHLY
PAYMENT TERMS

Sherman,  Clay & Co.

Kearny and Sutter Sts., San Francisco

INDEX

A		Page		Page	
Altos	18, 19, 33, 42	Chinese Wood Drums	93	Music Bags and Cases	109
Artillery Trumpets	74	Clarinets, Jean Marbeau	59	Blank Books, Paper and Cards	106
B		Couesnon & Cie. 20th Century	60-62	Clips	106
Bags, Band Instruments	49	Couesnon & Cie. American Perfection	62	Desks	104
Drums	85	Buffet, Crampon & Co.	63 64	Folios	107
Band Books and Cards	106	Clarinet Cases	65	Peus	107
Band Constitution and By-Laws	7	Clarinet Furnishings	65-67	Racks	104-105
Band Drums	78, 80	Clips, Music	106	Repair Paper and Linen	106
Band Folios	107	Coaching Horns	74	Stands	104-105
Band Formations for Marching	8	Concert Horns	34, 42	Stand Cases	105
Band, Instrumentation of	9	Concert Flutes	69	Mutes for Band Instruments	52
Band Instruments—		Conductors' Batons	110	O	
Brisson & Cie.	11 to 13	Conductors' Music Stands	105	Oboes (Hautbois) and Reeds	68
Jean Marbeau	14 to 23	Cornets	10 13, 14 18, 28 32, 40-41	Ocarinas	107
Couesnon & Cie. 20th Century	24 to 38	Cornet Cases	49	Officers' Bugles	74
Couesnon & Cie., American Perfection	39 to 47	Cornet Outfits	10	Oils	53
Band Instrument Bags	49	Couesnon & Cie. Band Instruments	24-47	Orchestra Bells	101
Band Instrument Cases	49 51	Cymbals	94	Hammers	103
Band Instrument Furnishings	52-53	Cymbal Beaters	83, 95	Orchestra Drums	76, 78, 79, 80
Band Instrument Mouthpieces	53	Cymbal Holders	95	Orchestra Effects	89-93
Band Instrument Mutes	52	Cymbal Pouch	94	Outfits, Cornet	10
Band Instrument Plating	112	D		P	
Band Instrument Polish	53	Drums, Band	78, 80	Persian Cymbals	94
Band Instrument Racks	53	Bass	81, 92	Piccolos	71-72
Band Lamps	53	Corps	77	Cases and Furnishings	72
Band Music Bags and Cases	109	Kettle	82	Piccolo Flageolets	73
Band Music Clips	106	Snare	76-80	Pitch Pipes	110
Baritones	21, 36, 45	Toy and Youths	75	Plating	112
Bass Drums	81-82	Drum Bags	85	Polish, Metal	53
Bass Drum and Cymbal Beaters	83	Cases	85	Position Indicator, Trombone	53
Bass Drum Heads	86	Drum and Cymbal Beaters	83	Post Horns	74
Bass Drum Music Racks	84	Drum Furnishings	86 88	Program Numbers	107
Bass Drum Slings	85	Heads	86	S	
Bass Drum Spurs	88	Music Racks	84	Saxophones	54-57
Bass Drum Sticks	88	Slings	85	Cases	58
Basses	21-23, 37 38, 46 47	Spurs	88	Furnishings	58
Bassoons	58	Stands	84	Second-hand Band Instruments	112
Bassoon Reeds	58	Drummers' Traps	89 93	Shanks and Slides for Band Instruments	52
Batons, Directors'	110	E		T	
Batons, Drum Majors'	74	Elmwood Band Folios	107	Tally Ho Horns	74
Beaters, Drum and Cymbal	83	F		Tambourines	96
Bells, Cow	92	Fales' Band Folios	107	Tenors	19, 36, 44
Bells, Orchestra and Band	101	Fifes	73	Tom Toms	90, 93
Bells, Parsifal	102	Flageolets	73	Triangles	94
Big Ben Music Binders	108	Flutes	68 70	Triangle Holders	95
Bones and Clappers	96	Flute Cases and Furnishings	70	Trombones	20, 35, 43
Books, Blank Music	106	Folios for Music	107	Trombone Oil	53
Brisson & Cie. Cornets	11 13	French Horns and Cases	48	Trombone Position Indicator	53
Bugles and Trumpets	74	G		Trumpets	41, 74
Bugle Cords	74	Gongs, Chinese	94	Tubas	22, 38, 46
Bugle Mouthpieces	53	Gummed Repair Paper and Linen	106	Tube-phones	97
C		H		Tuning Forks	110
Calfskin Heads	86	Helicon Bases	23	Tuning Pipes	110
Care of Wood Wind Instruments	59	Horns, Coaching	74	Turkish Cymbals	94
Cases, Band Instrument	49 51	French	48	Tympanies	82
Band Music	109	Hunting	74	V	
Clarinet	65	Horn Racks	53	Valve Oil	53
Clarinet Reed	67	I		Springs	52
Cornet	49	Indian Drums	90	W	
Cymbals	94	Infantry Bugles	74	Wood Drums, Chinese	93
Drum	85	K		X	
Flute	70	Kettle Drums and Sticks	82	Xylophones	98 99
Music Stand	105	M		Xylophone Hammers	103
Piccolo	72	Marimbaphones	100	Z	
Saxophone	58	Mallets	103	Zobos and Sonophones	111
Castanets	96	Mellophones	34, 42		
Cathedral Chimes	102	Metal Polish	53		
Cavalry Trumpets	74	Mouthpieces for Band Instruments	53		
Chinese Cymbals	94				
Chinese Gongs	94				
Chinese Oboes	93				
Chinese Drum or Tom Tom	93				

C. 3A377794

AUG 19 1914

Hc 1

all 1914

Information About Ordering, Free Trial, Length of Trial, Opening an Account, Etc.

OUR RELIABILITY

We have had a successful business career of more than forty years, and most of those who will receive this catalogue know our reputation for fair dealing and reliability. If you are unacquainted with us, ask any of your local banks or business houses regarding us or inquire of the Dun or Bradstreet mercantile agencies.

PRICES AND DISCOUNTS

The prices in this catalogue are strictly net on single instruments. Special prices will be made on complete sets or when goods are purchased in large quantities.

FREE TRIAL

It is as safe for you to purchase from us by mail as to come into our store and personally try and select the articles you wish. We realize that a dissatisfied purchaser is a lost customer, and to prevent any possibility of dissatisfaction all instruments are sent on Free Trial, with the understanding that you are not under any obligation to keep them if they do not please you. Not only are they to be exactly as represented, but they must be satisfactory in every particular or you are at liberty to return them at our expense and your money will be cheerfully refunded. You are to be the judge and jury—we shall accept your verdict without question.

LENGTH OF TRIAL

On all Band Instruments we allow ten days trial, whether you order a complete set or only a single instrument. On Wood Wind Instruments, viz: Clarinets, Flutes, Piccolos, Oboes, Bassoons, also Drums, we allow three days trial.

The transportation charges back to San Francisco are always at our expense if the instruments are not acceptable.

We allow this Free Trial no matter how you purchase: whether you send all cash with your order or make only a small payment.

IF YOU HAVE NO ACCOUNT WITH US

If you have no regular charge account with us, then fill out the "Application for Credit" form you receive with this catalogue and send it in with your order. When giving references, while it is better to give the names of merchants here or in your own town with whom you have traded, these are not absolutely necessary, as references from your Postmaster, Banker, Express Agent or other prominent persons, will be acceptable. If you prefer to have goods sent by Express or by Parcel Post C. O. D., please send enough cash on account to cover the transportation charges. This money will be deducted from the amount of the C. O. D., and the entire sum will be returned to you should the articles not be kept. If shipment is made by Express, we can allow you the trial privilege in accordance with our Free Trial offer, but this cannot be done by Parcel Post as the regulations do not at present permit of it.

HOW TO SEND MONEY

Remit by post-office money order, express money order, bank draft or cash in registered letter. We also accept postage stamps for small amounts.

SHIPPING INSTRUCTIONS

In ordering goods, mention the article and its catalogue number only. Do not cut out illustrations or descriptions. The method of shipment should be precisely stated, but in the absence of such instructions we will always ship the cheapest way.

About Easy Monthly Payments, Allowances for Old Instruments Against New Ones, Our Guarantee, Etc.

EASY MONTHLY PAYMENTS

We accept easy monthly payments on all instruments priced at \$15 upward, or on all single orders amounting to \$15 or more. The small increase of 5% is made in the price to cover interest on the money, the added bookkeeping expense, extra postage on statements and receipts for payments, etc. The size of the monthly payments will depend upon the total amount of the purchase and also upon the cash payment, but our requirements are always most reasonable and will suit any purse. We usually receive about one-quarter of the amount cash down, but are always willing to consider any reasonable basis of payment. When you have selected the article you wish, write and let us know just how it is convenient for you to pay for it. Amounts of less than \$15 are not payable in monthly installments.

EASY PAYMENT PLAN ON COMPLETE BAND SETS

We make very easy terms on complete sets of band instruments and no band need hesitate to purchase its outfit from us on such a basis. The payment that each member would be required to make would be very small indeed. The set would be sold at the regular cash prices and interest charged on the deferred payments at the rate of 8% per annum. The terms would vary somewhat, according to the size of the purchase, but the total cash payment would in no case exceed 20% of the entire amount while it would usually not be more than about 15%. The balance would be divided up into from ten to fifteen monthly payments, or even more. Always write us for special offers on complete band sets.

WE ACCEPT OLD INSTRUMENTS AS PART PAYMENT ON NEW ONES

If you have one to offer, ask for a description blank. From the information you give us thereon we shall be able to appraise the instrument without your going to the expense of sending it to us. You can then decide whether or not you wish to exchange. We do not seek to make a profit on used instruments, so our allowances for them are always exactly what we expect to sell them for again, less only the cost of what cleaning and repair work may be necessary and the expense of advertising them in our lists of second-hand instruments. It is obvious that on this basis our allowances are liberal. When you send an old instrument to us as part payment for a new one, always prepay the transportation charges upon it. Read article about second-hand instruments on page 112.

YOUR GUARANTEE WHEN DEALING WITH US — INSURANCE AGAINST DISSATISFACTION

We absolutely guarantee all goods in this catalogue to be exactly as represented. We have tried to describe them accurately, completely and honestly, and no transaction with us will be considered completed unless satisfaction results therefrom. We are ready at all times to cheerfully refund the entire amount paid and to stand the return transportation charges on any goods that do not realize your expectations or come up to our specifications. Cheaper grades of goods do not, of course, produce results or offer substantiability equal to the higher qualities, so it is not possible to give a sweeping or exact guarantee as to the length of wear or service. We do, however, guarantee that all goods will give satisfactory service in proportion to their cost or they will be replaced at our expense.

PARCEL POST RATES FROM SAN FRANCISCO

WEIGHTS AND INFORMATION

YOUR POSTMASTER WILL TELL YOU THE PARCEL POST ZONE IN WHICH YOUR POSTOFFICE IS LOCATED, MEASURING FROM SAN FRANCISCO, IF YOU DO NOT KNOW IT.

All merchandise shipped by mail now takes parcel post rates. Packages up to 4 ounces in weight are carried at the rate of 1 cent an ounce, regardless of distance. Packages over 4 ounces are charged for by the pound. The rate per pound varies according to the distance, which is measured by the Government zone system, each zone covering a certain number of miles from the point of shipment. Distances and rates are shown in the table below. Packages carried by parcel post are handled just like any other mail matter. They are delivered to your box by your rural mail carrier if you live on a rural route, or delivered to your door if you live in a city where there is a carrier service, or delivered to your local postoffice if you live where there is no carrier service.

NEW POSTAGE RATE TABLE FOR PARCEL POST SHIPMENTS, IN EFFECT JANUARY 1, 1914

This table shows the amount of postage by parcel post, according to the weight of the package and according to distance by zones

WEIGHT OF PACKAGE	AMOUNT OF POSTAGE REQUIRED							
	LOCAL ZONE	ZONES 1 AND 2	ZONE 3	ZONE 4	ZONE 5	ZONE 6	ZONE 7	ZONE 8
	For Shipments from our Store in San Francisco to Customers within San Francisco and those served by the San Francisco Postoffice	Not over 150 miles from San Francisco	151 to 300 miles from San Francisco	301 to 600 miles from San Francisco	601 to 1000 miles from San Francisco	1001 to 1400 miles from San Francisco	1401 to 1800 miles from San Francisco	Over 1800 miles from San Francisco
Over 4 ozs. up to 1 lb	\$0.05	\$0.05	\$0.06	\$0.07	\$0.08	\$0.09	\$0.11	\$0.12
Over 1 lb. up to 2 lbs.	.06	.06	.08	.11	.14	.17	.21	.24
Over 2 lbs. up to 3 lbs.	.06	.07	.10	.15	.20	.25	.31	.36
Over 3 lbs. up to 4 lbs.	.07	.08	.12	.19	.26	.33	.41	.48
Over 4 lbs. up to 5 lbs.	.07	.09	.14	.23	.32	.41	.51	.60
Over 5 lbs. up to 6 lbs.	.08	.10	.16	.27	.38	.49	.61	.72
Over 6 lbs. up to 7 lbs.	.08	.11	.18	.31	.44	.57	.71	.84
Over 7 lbs. up to 8 lbs.	.09	.12	.20	.35	.50	.65	.81	.96
Over 8 lbs. up to 9 lbs.	.09	.13	.22	.39	.56	.73	.91	1.08
Over 9 lbs. up to 10 lbs.	.10	.14	.24	.43	.62	.81	1.01	1.20
Over 10 lbs. up to 11 lbs.	.10	.15	.26	.47	.68	.89	1.11	1.32
Over 11 lbs. up to 12 lbs.	.11	.16	.28	.51	.74	.97	1.21	1.44
Over 12 lbs. up to 13 lbs.	.11	.17	.30	.55	.80	1.05	1.31	1.56
Over 13 lbs. up to 14 lbs.	.12	.18	.32	.59	.86	1.13	1.41	1.68
Over 14 lbs. up to 15 lbs.	.12	.19	.34	.63	.92	1.21	1.51	1.80
Over 15 lbs. up to 16 lbs.	.13	.20	.36	.67	.98	1.29	1.61	1.92
Over 16 lbs. up to 17 lbs.	.13	.21	.38	.71	1.04	1.37	1.71	2.04
Over 17 lbs. up to 18 lbs.	.14	.22	.40	.75	1.10	1.45	1.81	2.16
Over 18 lbs. up to 19 lbs.	.14	.23	.42	.79	1.16	1.53	1.91	2.28
Over 19 lbs. up to 20 lbs.	.15	.24	.44	.83	1.22	1.61	2.01	2.40
Over 20 lbs. up to 21 lbs.	.15	.25						
Over 21 lbs. up to 22 lbs.	.16	.26						
Over 22 lbs. up to 23 lbs.	.16	.27						
Over 23 lbs. up to 24 lbs.	.17	.28						
Over 24 lbs. up to 25 lbs.	.17	.29						
Over 25 lbs. up to 26 lbs.	.18	.30						
Over 26 lbs. up to 27 lbs.	.18	.31						
Over 27 lbs. up to 28 lbs.	.19	.32						
Over 28 lbs. up to 29 lbs.	.19	.33						
Over 29 lbs. up to 30 lbs.	.20	.34						
Over 30 lbs. up to 31 lbs.	.20	.35						
Over 31 lbs. up to 32 lbs.	.21	.36						
Over 32 lbs. up to 33 lbs.	.21	.37						
Over 33 lbs. up to 34 lbs.	.22	.38						
Over 34 lbs. up to 35 lbs.	.22	.39						
Over 35 lbs. up to 36 lbs.	.23	.40						
Over 36 lbs. up to 37 lbs.	.23	.41						
Over 37 lbs. up to 38 lbs.	.24	.42						
Over 38 lbs. up to 39 lbs.	.24	.43						
Over 39 lbs. up to 40 lbs.	.25	.44						
Over 40 lbs. up to 41 lbs.	.25	.45						
Over 41 lbs. up to 42 lbs.	.26	.46						
Over 42 lbs. up to 43 lbs.	.26	.47						
Over 43 lbs. up to 44 lbs.	.27	.48						
Over 44 lbs. up to 45 lbs.	.27	.49						
Over 45 lbs. up to 46 lbs.	.28	.50						
Over 46 lbs. up to 47 lbs.	.28	.51						
Over 47 lbs. up to 48 lbs.	.29	.52						
Over 48 lbs. up to 49 lbs.	.29	.53						
Over 49 lbs. up to 50 lbs.	.30	.54						

Within local zone and zones 1 and 2, packages up to 50 pounds in weight are carried. The limit of weight for all other zones is 20 pounds.

No article can be shipped by parcel post which is more than 36 inches long or which exceeds the size limit of 72 inches in length and girth combined. A list of the articles in this catalogue which are unmailable will be found on the following page.

RATE ON MUSIC BOOKS AND MUSIC WRITING PAPER

Packages of Music Writing Books and Paper up to and including 8 ounces in weight will be carried at the rate of 1 cent for 2 ounces to any part of the United States, regardless of distance. Packages over 8 ounces take the regular parcel post rates according to rate and zone.

C. O. D. PARCEL POST SERVICE

If you wish goods shipped by parcel post Collect on Delivery, add 10 cents to the regular postage. Goods cannot be sent by this method when they exceed \$100 in value. The parcel post regulations do not permit of the contents of a C. O. D. package being examined by the person to whom it is addressed until it has been receipted for and all charges paid.

INSURED PARCEL POST

Merchandise is shipped by parcel post at the customer's risk unless the package is insured. Insurance will be effected only upon request. Packages in value up to \$25 will be insured for a fee of 2½ cents; over \$25, but not exceeding \$50, for a fee of 5 cents.

CAUTION—When Obligated to Return Goods to Us by Parcel Post

If for any reason you find it necessary to return goods to us by parcel post, do not under any circumstances put a letter or money in the package. The Government will not carry packages containing letters at parcel post rates. Such enclosures change the rate to first-class postage. We will not be responsible for letters or money sent in the same package with the goods. When returning goods by parcel post, send the bill or any other papers relating to the order in a separate letter.

On the following page you will find the shipping weights of all articles in this catalogue that can be sent by parcel post.

Please remember that an amount sufficient to pay postage must be included with your order, as it must be paid in advance. The Government has not provided for the collection of postage on delivery. If in doubt as to how much postage is required for any package you are perfectly safe in enclosing even more than you think necessary, for we will ship by the most economical method and will return to you any amount that is left over.

SHIPPING WEIGHT OF GOODS IN THIS CATALOGUE THAT CAN BE SHIPPED BY PARCEL POST

Where the weight is four ounces or less, the postage is given alongside the article

PAGE	ARTICLE	WEIGHT Lbs.	PAGE	ARTICLE	WEIGHT LBS.	PAGE	ARTICLE	WEIGHT LBS.
10	Nos. R0 $\frac{1}{2}$ -R0 $\frac{1}{2}$ S, R01-R01S, R010-R010S, Cornet outfits.	6		Nos. R25, R26, R28, R39 Snare Drums.	8	94	No. R1 Cymbals.	1
11-12-13-15-16-17-18	All Cornets.	4		No. R27 Snare Drums.	7		Nos. R2, R2 $\frac{1}{2}$ Cymbals.	2
18	Nos. R206-R206SB Altos.	7	78	No. R81 Snare Drums.	8		Nos. R3, R4, R5, R6 Cymbals.	4
19	Nos. R204-R204SB Altos.	8		Nos. R82, R83, R87 Snare Drums.	10		Nos. R50, R8 Cymbals.	5
28-29-30-31-32	All Cornets.	4	79	Nos. R90, R95 Snare Drums.	14		Nos. R60, R10 Cymbals.	6
33	Nos. R352-R352C Altos.	7		No. R51 Snare Drums.	10		No. R12 Cymbals.	9
	Nos. R350-R350C Altos.	8		Nos. R53, R55, R57 Snare Drums.	11	94	Nos. R11, R13, R15 Chinese Cymbal, single.	2
40	Nos. R819-R819D, R821-R821D Cornets.	4	80	Nos. R77, R79 Snare Drums.	8		No. R17 Chinese Cymbal, single.	3
41	Nos. R825-R825D Cornets.	4		Nos. R5, R127, R210 Snare Drums.	10		No. R19 Chinese Cymbal, single.	4
	Nos. R829-R829D Trumpets.	5		No. R228 Snare Drums.	8		No. R21 Chinese Cymbal, single.	5
42	Nos. R835-R835D Altos.	8	83	No. R7 Pedal.	8		No. R23 Chinese Cymbal, single.	6
49	Nos. R72, R73, R75, R76 Cornet cases.	3		No. R8 Pedal.	11		No. R35 Chinese Gong.	5
	Nos. R1, R4, R5, R6, R164 Cornet cases.	6	84	Nos. R4, R5 Pedals.	4		No. R37 Chinese Gong.	6
50	No. R22 Alto case.	5		Nos. R8, R10, R11 Snare Drum stands.	3		No. R39 Chinese Gong.	9
	No. R25 Alto case.	5		No. R12 Drum and Music stand.	5	97	No. R8 Cymbal Sack.	2
51	No. R125 Alto case.	6	85	No. R3 Drum bag.	2		No. R2 Tubephone.	5
54	No. R100 $\frac{1}{2}$ Saxophone.	7		Nos. R10, R11 Drum cases.	7		No. R4 Tubephone.	12
	No. R101 $\frac{1}{2}$ Saxophone.	10		Nos. R5, R12 Drum cases.	6		No. R2 Xylophone.	5
56	Nos. R0-R0 $\frac{1}{2}$ Saxophone.	7		No. R14 Drum cases.	7		No. R5 Xylophone.	8
	Nos. R1-R1 $\frac{1}{2}$ Saxophone.	10		Nos. R8, R9 Drum cases.	6		No. R6 Xylophone.	18
57	Nos. R10-R10 $\frac{1}{2}$ Saxophone.	6	88	No. R135 Locomotive Bell.	4	102	No. R13 Orchestra Bell stand.	3
	Nos. R11-R11 $\frac{1}{2}$ Saxophone.	10		No. R139 Silent Drum.	2	103	No. R15 Orchestra Bell stand.	3
	Nos. R2-R4 Bassoons.	7	89	No. R101 Anvil.	1		No. R17 Xylophone stand.	5
59-62-64	All Clarinets.	3		No. R103 Anvil.	7	104-105	Nos. R1, R3, R6N, R31, R33, R35, R15, R14, R22, R29 Music Stands.	3
66	Nos. R0, R1, R2, R3 Clarinet cases.	2	90	No. R197 Cyclone Horn.	4		No. R.X Music Desk.	1
	Nos. R5, R4, R40, R50 Clarinet cases.	6		No. R173 Indian Drum.	3		Nos. R1, R4, R24 Music Stand cases.	1
	No. R10 Clarinet cases.	4		No. R133 Bell Plate.	3	107	No. R118 Eagle Folios, dozen.	2
	No. R6 Clarinet cases.	7		No. R135 Locomotive Bell.	4		No. R119 Eagle Folios, dozen.	3
	No. R5 Clarinet cases.	8	91	No. R183 Poppun.	2		No. R101 Elmwood Folios, dozen.	2
68	Nos. R3-R3 $\frac{1}{2}$, R5-R5 $\frac{1}{2}$ Oboes.	3		No. R182 Rattle.	2		No. R103 Elmwood Folios, dozen.	4
	All Flutes.	2		No. R181 Rattle.	1		No. R1 Fales Folios, dozen.	2
69	All Flutes.	3		No. R187 Slap Stick.	1		No. R2 Fales Folios, dozen.	4
70	Nos. R7 $\frac{1}{2}$ and R8 $\frac{1}{2}$ Flutes.	3		No. R189 Sleigh Bells.	2		No. R2 $\frac{1}{2}$ Fales Folios, dozen.	5
	Nos. R330-R333 Flute cases.	2		No. R191 Sleigh Bells.	3		No. R3 Fales Folios, dozen.	7
71-72	All Piccolos.	1	92	No. R24 Sleigh Bells.	2	108	No. R301 Big Ben Binder.	1
74	Nos. R90-R90N, R91, R93-R93N, R93 $\frac{1}{2}$ -R93 $\frac{1}{2}$ N Bugles.	1		No. R33 Sleigh Bells.	3		No. R303 Big Ben Binder.	2
	Nos. R94-R94N Bugles.	2	93	No. R160 Surf and Rain effect.	7		Nos. R305, R308 Big Ben Binder.	2
	Nos. R95-R95N, R96-R96N Trumpets.	3		No. 198 Comedy Whistle.	1		Nos. R201, R215, R238, R227, Folios.	3
75	Nos. R4 $\frac{1}{2}$, R5 $\frac{1}{4}$, R6 $\frac{1}{2}$, R7 $\frac{1}{2}$ Toy Drums.	7		No. R27 Whistle.	1		Nos. R30 $\frac{1}{2}$, R31, R50 Folios.	2
	No. R8 $\frac{1}{2}$ Youth's Drum.	8		No. R14 Whistle.	2	109	Nos. R1464, R1466, R1476, R1484, R1488 Music Satchels.	3
76	Nos. R19, R20 Snare Drums.	8		No. R193 Whistle.	1		No. R1497 Music case.	4
	Nos. R22, R23 Snare Drums.	9		No. R194 Whistle.	1		No. R1499 Music case.	3
				No. R195 Whistle.	2	111	No. R59 Zoboophone.	1
				No. R199 Whistle.	2		No. R102 Zobo Cornetto.	1
				No. R175 Wood Drum.	2		Nos. R3, R4 Zobo Cornets.	3
				No. R176 Wood Drum.	3		No. R5 Zobo Saxophone.	4
				No. R177 Tom Tom.	4		No. R6 Zobo Slide Trombone.	4
				No. R21 Tom Tom holder.	1		No. R7 Zobo Bass Horn.	4
				No. R22 Wood Block holder.	1		Nos. R8, R9 Zobo Prof. Cornets.	3
				No. R24 Wood Block and Squawker holder.	1		No. R8, R9, R10 Sonophones.	1
				No. R179 Oboe.	1		No. R11 Sonophone Cornet.	2
				No. R180 Oboe.	2		No. R12 Sonophone Slide Trombone.	4
							No. R13 Sonophone Bass Horn.	3

GOODS WHICH CANNOT BE SHIPPED BY PARCEL POST

The following goods are either too heavy for Parcel Post shipment (except in the 1st and 2nd zones), or they exceed the length or the girth limits that have been established:

Band Instruments—All Mellophones, Tenors, Valve and Slide Trombones, Baritones, Basses, French Horns, Tenor and Baritone Saxophones; also all cases for these instruments except Bags.

Drums All Bass Drums and Tympanies, also all Corps Drums Nos. R1, R61, R63, R65, R67 and Band Drum No. R84.

Bells, Xylophones, etc.—All Orchestra Bells, Parsifal Bells (except Nos. R11 $\frac{1}{2}$, R13 $\frac{1}{2}$, R14 $\frac{1}{2}$, R15 $\frac{1}{2}$, R22 $\frac{1}{2}$ in 1st and 2nd zones), Cathedral Chimes, Tubephone No. R6 and Xylophones Nos. R7, R14, R14 $\frac{1}{2}$, R16, R16 $\frac{1}{2}$ (except in the 1st and 2nd zones), R117 $\frac{1}{2}$, R118 $\frac{1}{2}$, R119 $\frac{1}{2}$, R120 $\frac{1}{2}$, R121 $\frac{1}{2}$.

Miscellaneous Tally Ho Horn No. R99, all Drum Major's Batons, Music Stands Nos. R410, R440, R25 and R26.

CONSTITUTION AND BY-LAWS FOR THE GOVERNMENT OF A BAND

Without proper organization and systematic methods, no band can hope to be a permanent success. Methods must be adopted to insure regular and prompt attendance at rehearsals, to secure and promote earnest co-operation among the members, to devise ways and means of obtaining the financial support of the merchants and municipal authorities, etc. The first steps looking toward permanent and proper organization are the adoption of a Constitution and By-Laws, of which the following will serve as a model:

CONSTITUTION

- ARTICLE I. This organization shall be known as the.....Band.
- ARTICLE II. Meetings shall be held Tuesday and Friday night, of each week, beginning at 7:30 from October 1st to April 1st, and at 8:00 o'clock from April 1st to October 1st.
- ARTICLE III. The officers of this organization shall consist of a president, vice-president, secretary, treasurer and librarian, of which the first four shall be elected annually and the last shall be appointed by the president.
- ARTICLE IV. It shall be the duty of the president to preside at all business meetings (excepting the rehearsals and performances) of the organization, to appoint all committees, to preserve order and decorum and to decide all questions when a tie vote occurs. He shall be entitled to vote at no other time.
- ARTICLE V. It shall be the duty of the vice-president, in the absence of the president, to perform the duties of the president.
- ARTICLE VI. It shall be the duty of the secretary to keep a record of the proceedings at all meetings and to attend to all correspondence. (Note: The offices of secretary and treasurer may be combined in the same person.)
- ARTICLE VII. It shall be the duty of the treasurer to keep a correct account of all moneys received for dues and from other sources, to pay all accounts when requested to do so by written order of the organization signed by the president and secretary. He shall also make out bills and collect the amounts due the organization as dues and for services rendered, making reports quarterly (or semi-annually) or whenever called upon to do so by a vote of the organization at a regular meeting.
- ARTICLE VIII. It shall be the duty of the librarian to take charge of all music and other property of the organization.
- ARTICLE IX. It shall be the duty of every active member to attend all regular meetings for business or rehearsal and all special meetings when properly advised of the same. If he fails to attend he must pay the penalty imposed for such offense, unless excused by a majority vote of the band.
- ARTICLE X. A majority vote of the members of the organization shall elect any elective officer of the organization.

BY-LAWS

- ARTICLE I. Section 1. There shall be an annual election of officers at the first regular meeting of the organization in the month of.....
- Sec. 2. Candidates for office shall be voted for by ballot and must receive a majority of the votes cast to entitle them to election.
- Sec. 3. All officers so elected shall assume their duties on the.....next ensuing their election, and shall continue for the term of one year thereafter, unless otherwise provided for.
- ARTICLE II. Each member of the organization shall pay.....cents a week for dues.
- ARTICLE III. Any member who shall be absent from a rehearsal or shall leave the rehearsal room without permission of the leader or musical director, shall be fined.....cents for each offense, and in the case of a member's continual absence from rehearsals he shall be expelled.
- ARTICLE IV. No fine shall be remitted except by a majority vote of the organization.
- ARTICLE V. Applications for membership shall be presented in writing and action deferred for one week. A majority vote will elect.
- ARTICLE VI. Each member shall be held responsible for the organization's property in his possession, and in case of loss or damage (ordinary wear excepted) he must pay said loss or damage or be expelled from the organization.
- ARTICLE VII. Any member may resign from the organization by handing his resignation in writing to the secretary. By so doing he shall forfeit all rights or claims to any of the organization's property and must surrender same in good order to the librarian before his resignation can be accepted.
- ARTICLE VIII. Expulsions from the organization shall be by a two-thirds vote of the entire membership of the organization. Any member expelled shall forfeit all rights or claims to any of the property of the organization.
- ARTICLE IX. Should any member desire to have these by-laws revised or amended, he shall present his resolution in writing, which shall be read at two regular meetings of the organization, and after the second reading shall be passed if approved by a two-thirds vote of the organization.

MARCHING FORMATIONS

Band of 8 Pieces

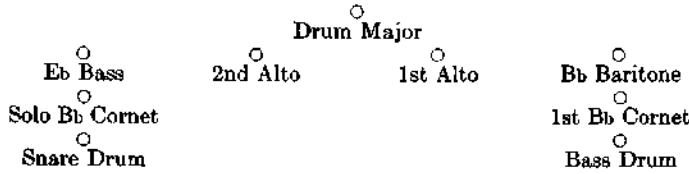

Band of 10 Pieces

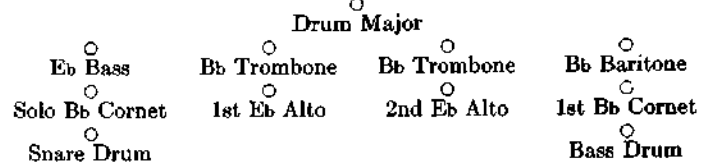

Band of 12 Pieces

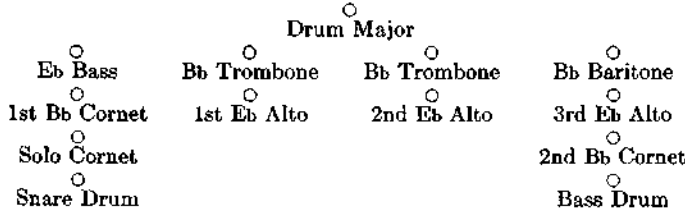

Band of 13 Pieces

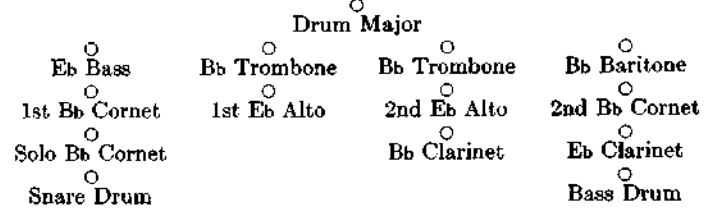

Band of 14 Pieces

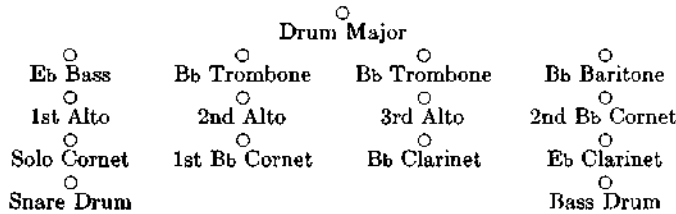

Band of 15 Pieces

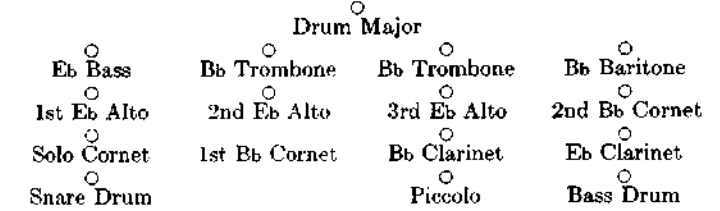

Band of 16 Pieces

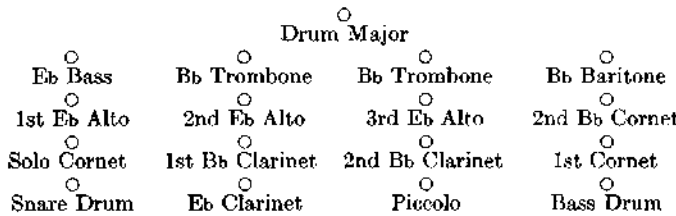

Band of 17 Pieces

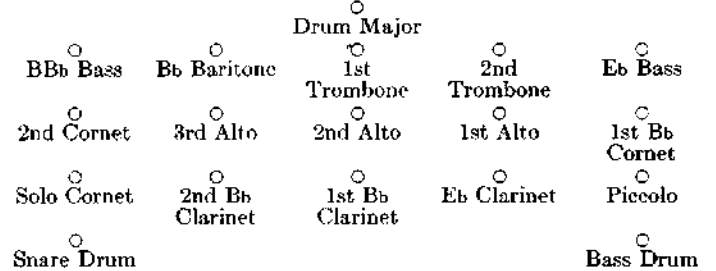

Band of 20 Pieces

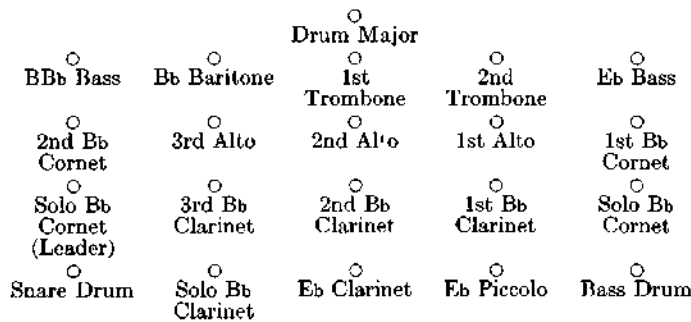

Band of 26 Pieces

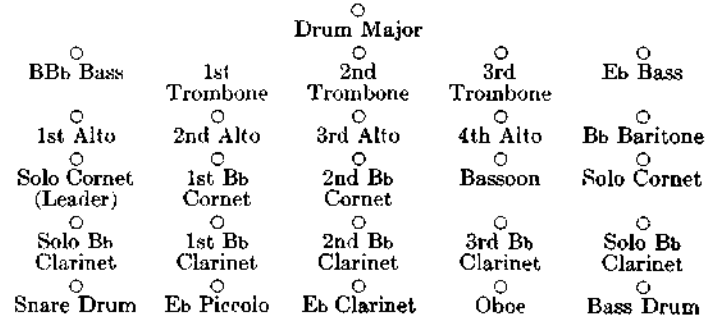

Band of 30 Pieces

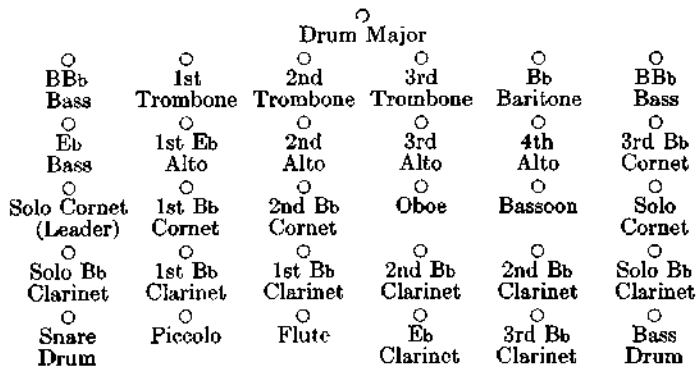

Band of 35 Pieces



INSTRUMENTATION OF BANDS

In the formation of Brass Bands we recommend the following combinations of instruments as being the best to produce power, variety of tone, harmony and well balanced effect:

Band of Eight	Band of Ten	Band of Twelve	Band of Thirteen
2 B \flat Cornets. (or 1 E \flat Clarinet and 1 B \flat Cornet.)	2 B \flat Cornets. (or 1 E \flat Clarinet and 1 B \flat Cornet.)	3 B \flat Cornets. (or 1 E \flat and B \flat Clarinet and 1 Cornet.)	1 E \flat Clarinet. 1 B \flat Clarinet } or 2 Clarinets 3 B \flat Cornets } and 2 Cornets
2 E \flat Altos or Mellophones.	2 E \flat Altos or Mellophones.	3 E \flat Altos or Mellophones.	2 E \flat Altos or Mellophones.
1 B \flat Baritone.	2 B \flat Trombones.	2 B \flat Trombones.	2 B \flat Trombones.
1 E \flat Bass.	1 B \flat Baritone.	1 F \flat Baritone.	1 B \flat Baritone.
1 Snare Drum.	1 E \flat Bass.	1 E \flat Bass.	1 E \flat Bass.
1 Bass Drum.	1 Snare Drum.	1 Snare Drum.	1 Snare Drum.
	1 Bass Drum.	1 Bass Drum.	1 Bass Drum.
Band of Fourteen	Band of Fifteen	Band of Sixteen	Band of Seventeen
1 E \flat Clarinet.	1 Piccolo.	1 Piccolo.	1 Piccolo.
1 B \flat Clarinet } or 2 Clarinets	1 E \flat Clarinet.	1 E \flat Clarinet.	1 E \flat Clarinet.
3 B \flat Cornets } and 2 Cornets.	1 B \flat Clarinet } or 2 Clarinets	2 B \flat Clarinets.	2 B \flat Clarinets.
3 E \flat Altos or Mellophones.	3 B \flat Cornets } and 2 Cornets.	3 E \flat Cornets.	3 E \flat Cornets.
2 B \flat Trombones.	3 E \flat Altos or Mellophones.	3 E \flat Altos or Mellophones.	3 E \flat Altos or Mellophones.
1 B \flat Baritone.	2 B \flat Trombones.	3 B \flat Trombones.	2 B \flat Trombones.
1 E \flat Bass.	1 B \flat Baritone.	1 B \flat Baritone.	1 B \flat Baritone.
1 Snare Drum.	1 E \flat Bass.	1 E \flat Bass.	1 E \flat Bass.
1 Bass Drum.	1 Snare Drum.	1 Snare Drum.	1 BB \flat Bass.
	1 Bass Drum.	1 Bass Drum.	1 Snare Drum.
			1 Bass Drum.
Band of Twenty	Band of Twenty-five	Band of Thirty	Band of Thirty-five
1 Piccolo.	1 Piccolo.	1 Piccolo.	1 Piccolo.
1 E \flat Clarinet.	1 Oboe (or Clarinet).	1 Flute.	1 Flute.
4 B \flat Clarinets } or 5 Clarinets	1 E \flat Clarinet.	1 Oboe.	1 Oboe.
4 B \flat Cornets } and 3 Cornets.	5 B \flat Clarinets.	1 E \flat Clarinet.	1 E \flat Clarinet.
3 E \flat Altos or Mellophones.	1 Bassoon (or Saxophone).	7 B \flat Clarinets.	9 B \flat Clarinets.
2 B \flat Trombones.	4 B \flat Cornets.	1 Bassoon (or Saxophone).	1 Bassoon or Clarinet.
1 Baritone.	4 E \flat Altos or Mellophones.	5 B \flat Cornets.	1 Alto Saxophone.
1 E \flat Bass.	3 Trombones.	4 E \flat Altos.	1 Tenor Saxophone.
1 BB \flat Bass.	1 Baritone.	3 B \flat Trombones.	1 Baritone Saxophone.
1 Snare Drum.	1 E \flat Bass. } or 2 BB \flat Basses.	1 Baritone.	5 B \flat Cornets.
1 Bass Drum.	1 BB \flat Bass. }	1 E \flat Bass.	4 E \flat Altos.
	1 Snare Drum.	2 BB \flat Basses.	3 B \flat Trombones.
	1 Bass Drum.	1 Snare Drum.	1 Baritone.
		1 Bass Drum.	1 E \flat Bass.
			2 BB \flat Basses.
			1 Snare Drum.
			1 Bass Drum.

Tenors may be substituted for Trombones if preferred. Also Clarinet for Oboe and Saxophone for Bassoon.

Correspondence is invited from new bands which are not yet completely organized. We have experienced bandmen in our employ who are thoroughly conversant with all matters relative to formation, equipment, best instrumentation and all other details attendant upon correct and expeditious organization, and their helpful suggestions and knowledge are at your service.

ATTRACTIVE CORNET OUTFITS FOR BEGINNERS

BRISSON & CIE.

Inexpensive but well made and substantial instruments. Manufactured especially for us after the best American models. Greatly superior to the very cheaply constructed cornets sold at similar prices by Eastern mail order concerns and department stores. Not toys, but serviceable, practical instruments, easy to blow, with free acting pistons and well in tune.

THE "BEGINNER'S" CORNET OUTFIT

Includes a Brisson & Cie. Cornet with light piston valves, B \flat and A shanks, mouthpiece, music rack, Eclipse Self-Instructor and imitation leather case.

No.	Each
R0 $\frac{1}{2}$ —Brass, highly polished.....	\$ 9.75
R0 $\frac{1}{2}$ N—Same, nickel plated	11.75
R0 $\frac{1}{2}$ S—Same, silver plated, satin finish.....	16.25



THE "STUDENT" CORNET OUTFIT

This outfit consists of a Brisson & Cie. Light Piston Valve B \flat Cornet in high and low pitch, furnished with German silver mouthpiece, B \flat and A shanks, music rack, water key; good, black pebbled leather satchel, hand sewed and lined with fleeced flannel, and an Eclipse Self-Instructor. This Cornet can be used for either band or orchestra.

No.	Each
R01—Brass, highly polished, a higher grade Cornet and better case than No. R0 $\frac{1}{2}$	\$12.50
R01N—Same, nickel plated.....	14.50
R01S—Same, silver plated, satin finish.....	19.00

Cornet Outfits Nos. R0 $\frac{1}{2}$ —R0 $\frac{1}{2}$ S and R01—R01S



THE "STUDENT" SPECIAL CORNET OUTFIT

This outfit includes a handsomely engraved Brisson & Cie. Light Piston Valve B \flat Cornet in high and low pitch, with German silver mouthpiece, B \flat and A shanks, music rack and water key; good, black pebbled leather satchel, hand sewed and lined with fleeced flannel, and an Eclipse Self-Instructor.

Cornet can be used in either band or orchestra.

No.	Each
R010—Brass, handsomely engraved and highly polished.....	\$15.50
R010N—Same, nickel plated.....	17.50
R010S—Same, silver plated, satin finish.....	22.00

Cornet Outfits Nos. R010—R010S

Any of the above instruments will be accepted at any time as part payment on a Jean Marbeau, Couesmon & Cie. or other Cornet of better grade.

Sold on the Easy Monthly Payment Plan. See page 4 for explanation of terms.

LOW PRICED CORNETS FOR BEGINNERS

BRISSON & CIE.

No Better Instruments Made for the Money

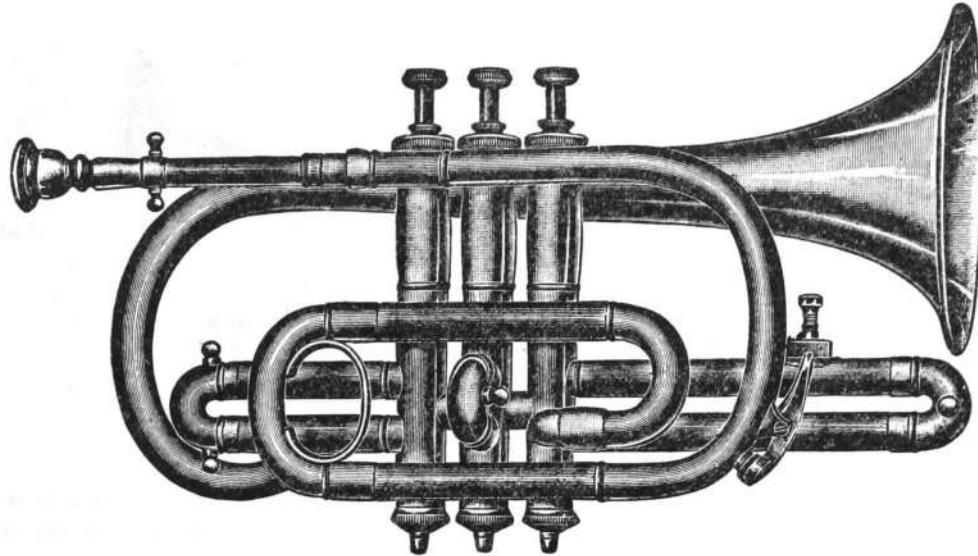

Although low priced this instrument is well made throughout, has a light piston action and a good free air passage. It is of up-to-date medium length model and comes equipped with B \flat and A shanks, German silver mouthpiece and music rack. Built in high pitch with tuning slide sufficiently long to draw to low pitch.

No.	Each
R0 —Brass, highly polished.....	\$ 8.00
R0N—Same, nickel plated.....	10.00

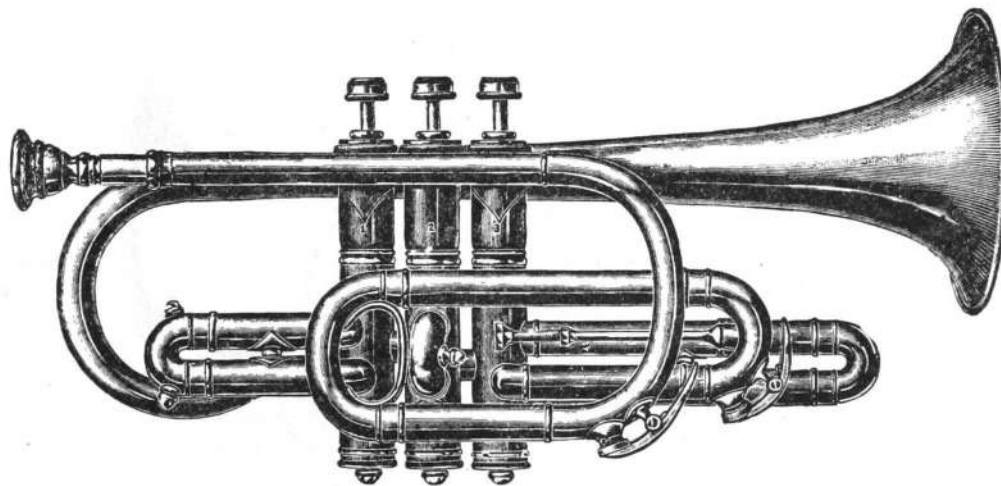

Another inexpensive Cornet in which we offer wonderful value for the money. The instrument is built on graceful lines with continuous mouthpipe avoiding the use of shanks, is free and easy blowing, has improved short action German silver light valves and is equipped with the quick change to A attachment so necessary for orchestra work. The valve buttons are German silver inlaid with pearl. Built in High Pitch with an extra Low Pitch tuning slide. Furnished with German silver mouthpiece and a music lyre.

No.	Each
R3 —Brass, highly polished.....	\$12.00
R3N—Same, nickel plated.....	14.00

CORNETS AT POPULAR PRICES

BRISSON & CIE.

Suitable for Young Bands and Students

B \flat and A
Cornet

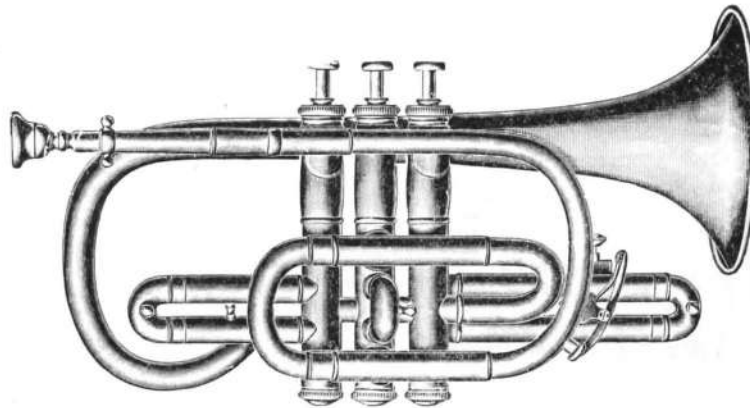

High and Low
Pitch

A Besson model Cornet of correct scale and surprising blowing qualities for its price. Short action, light French piston valves well fitted. Equipped with a tuning slide long enough to draw to low pitch, B \flat and A shanks, German silver mouthpiece and music lyre.

No.	Each
R1 —Brass, highly polished.....	\$10.00
R1N—Same, nickel plated.....	12.00

B \flat and A
Cornet

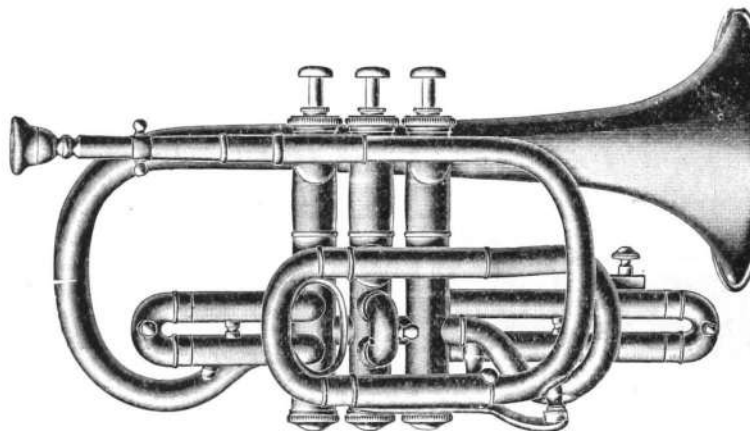

High and Low
Pitch

This Brisson Cornet is built on the lines of the Courtois, a make which was for many years regarded as the world's standard. It has a double water key, is of large, free bore, easy blowing and well in tune. The tuning slide is of sufficient length to draw to low pitch. Furnished with B \flat and A shanks, German silver mouthpiece and music lyre.

No.	Each
R2 —Brass, highly polished.....	\$11.50
R2N—Same, nickel plated.....	13.50

A green felt bag to fit any of the above cornets, \$0.60. Imitation leather satchel, \$1.60. Genuine leather, \$2.50 and \$3.50. See Page 49.

See Page 6 for shipping weights.

ATTRACTIVELY DECORATED CORNETS

BRISSON & CIE.

B \flat AND A

HIGH AND LOW PITCH

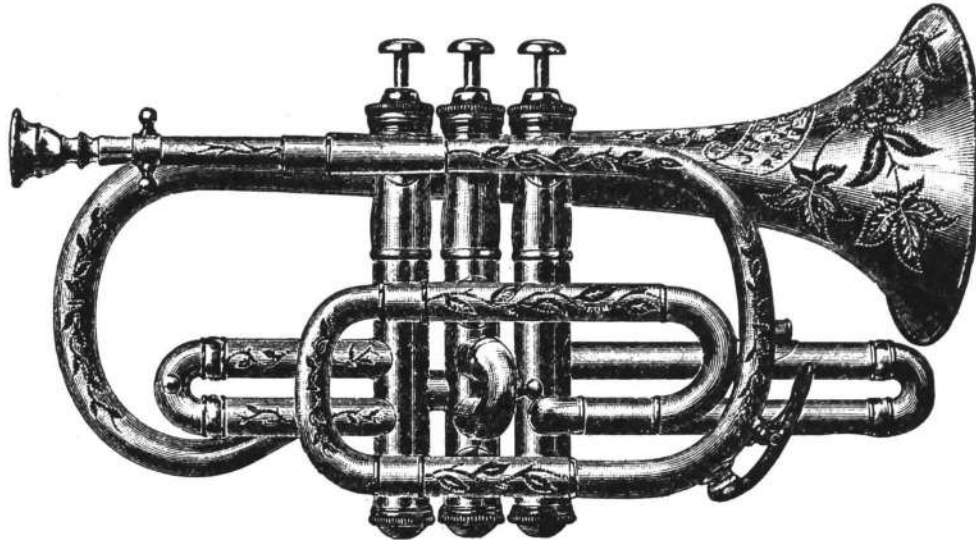

Besson model, handsomely engraved, light action German silver French piston valves. Tuning slide made sufficiently long to draw to low pitch. Furnished with B \flat and A shanks, German silver mouthpiece and music rack.

No.	Each
R10 —Brass, highly polished.....	\$13.00
R10N—Same, nickel plated.....	15.00
R10S—Same, silver plated, satin finish.....	19.50

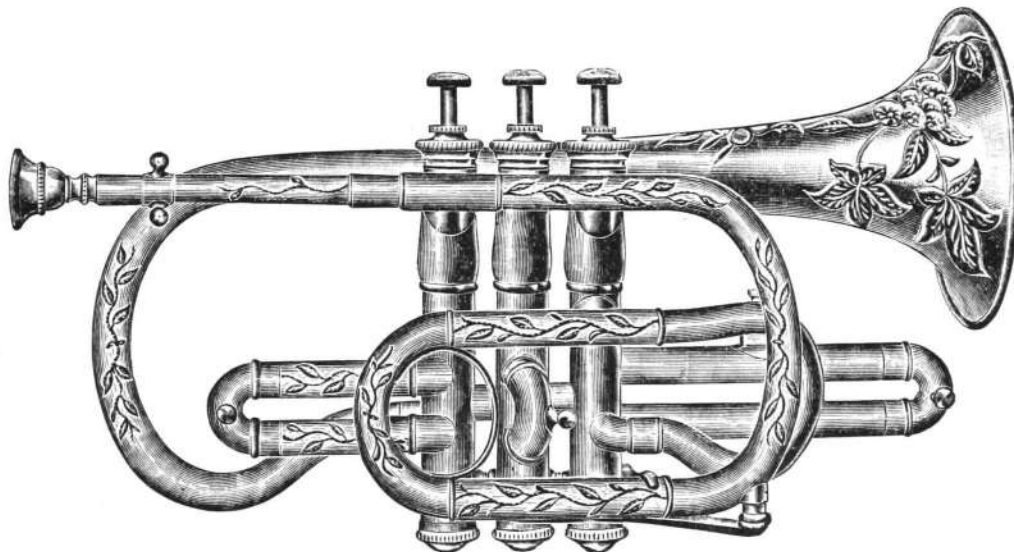

Courtois model, double water key, handsomely engraved, light action German silver French piston valves. Tuning slide draws to low pitch. Furnished with B \flat and A shanks, German silver mouthpiece and music rack.

No.	Each
R20 —Brass, highly polished.....	\$15.00
R20N—Same, nickel plated.....	17.00
R20S—Same, silver plated, satin finish.....	21.50

JEAN MARBEAU BAND INSTRUMENTS

PATTERNED ON THE FINEST AMERICAN MODELS. THOROUGHLY SUBSTANTIAL. LIGHT, SHORT ACTION. EASY BLOWING. WELL IN TUNE

Unapproached by any other instruments sold at similar prices

We have been equipping bands with Jean Marbeau instruments for almost a quarter of a century, invariably with complete satisfaction, and we unhesitatingly assert that their equal cannot be had elsewhere for anything like the low prices at which we offer them. There are no secrets connected with their excellence—the explanation of their superiority is a very simple one. Nothing but the finest material is used and none but adult workmen are engaged in their manufacture, even for the least important details of construction. Children are employed very largely in the manufacture of most other European makes of low and medium priced band instruments, with the result that it is impossible to reach the high standard of workmanship maintained in this factory. Only the best makers to be had are employed—none is retained who fails to come up to the standard.

As a result the Jean Marbeau instruments are superior in every respect, and a horn is produced which stands far more use, blows more freely and is much more accurate in its scale than all others similarly priced. The metal is of the best quality and of adequate weight, and the bores are liberally large, producing a full round quality of sound, not the thin piping tone of the numerous, small bore, cheaply made, light-weight instruments sold by Eastern mail order houses, department stores and others. The valves are correctly and carefully made, cleanly soldered, carefully fitted and accurately ground into the tubing, so that they have that lightness and decisiveness of action so indispensable for good execution. All slides are accurately fitted, so that they can be drawn quickly and easily. The bracings are strong and substantial, and the instruments are modeled on the lines of the best and most popular American makes.

All Marbeaus are equipped with rod and button low-pitch device, so that the horn can be used in a band playing in either high or low pitch.

Every instrument is furnished with music rack, German-silver mouthpiece and water key.

SPECIAL PRICES ON COMPLETE OUTFITS

WRITE FOR QUOTATIONS

JEAN MARBEAU SILVER PISTON BAND INSTRUMENTS

HIGH AND LOW PITCH

Latest American Models. Short, Light Action. Easy Blowing. Correct Scale.

E^b CORNET

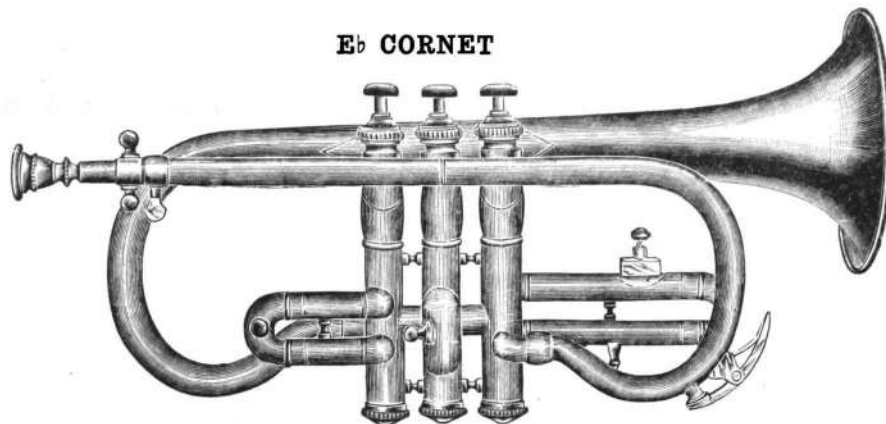

Nos. R200—R200SB

Each instrument supplied with mouthpiece, music lyre and shank for low pitch.

No.	Each
R200 —Best quality brass, highly polished.....	\$ 9.50
R200N —Same, nickel plated	11.50
R200SF—Same, triple silver plated, rich satin finish, inside of bell highly burnished	16.00
R200SB—Same, triple silver plated, highly burnished throughout.....	17.50

Burnished gold plating inside of bell, \$3.00 extra.

B^b CORNET

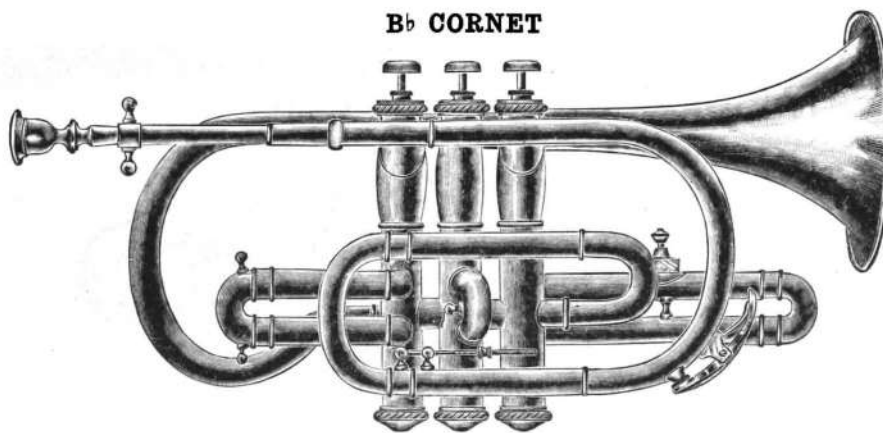

One of our most popular Cornets with young bands.

Easy Blowing, Correct Scale, Fine Tone Quality.

Nos. R202—R202SB.

THE BEST AND MOST SERVICEABLE CORNET MANUFACTURED AT THE PRICE

Fitted with Low Pitch Rod and Button Device located where it is out of the way of the fingers when playing. Each instrument furnished with B^b and A shanks, mouthpiece and music lyre.

No.	Each
R202—Best quality brass, highly polished.....	\$12.00
R202N—Same, nickel plated.....	14.00
R202SF—Same, triple silver plated, rich satin finish, inside of bell highly burnished	18.50
R202SB—Same, triple silver plated, highly burnished throughout.....	20.00

Burnished gold plating inside of bell, \$3.00 extra.

A C crook can be fitted to the above instrument at an extra cost of \$6.00 in brass, \$6.50 nickel plated, \$7.00 silver plated satin finish, \$7.50 silver plated burnished finish.

Purchase a case when you get your Cornet, and save additional transportation charges. A nice satchel for any of the above Cornets, \$2.50; solid sole leather, \$3.50; an elegant leather case, silk and plush lined, \$8.00. See page 49.

JEAN MARBEAU SILVER PISTON BAND INSTRUMENTS

Latest American Models. Short, Light Action. Easy Blowing. Correct Scale
HIGH AND LOW PITCH

C CORNET

To play with piano in C or B_b in band. Equally well in tune in both C and B_b

Each instrument fitted with Rod and Button Low Pitch Attachment and furnished with C shank, B_b crook, mouthpiece and music lyre.

No.	Each
R203 —Best quality brass, highly polished.....	\$12.00
R203N —Same, nickel plated	14.00
R203SF —Same, triple silver plated, rich satin finish, inside of bell highly burnished	18.50
R203SB —Same, triple silver plated, highly burnished throughout.....	20.00

Burnished gold plating inside of bell, \$3.00 extra.

American Trumpet Style or Long Model Cornet

B_b AND A HIGH AND LOW PITCH

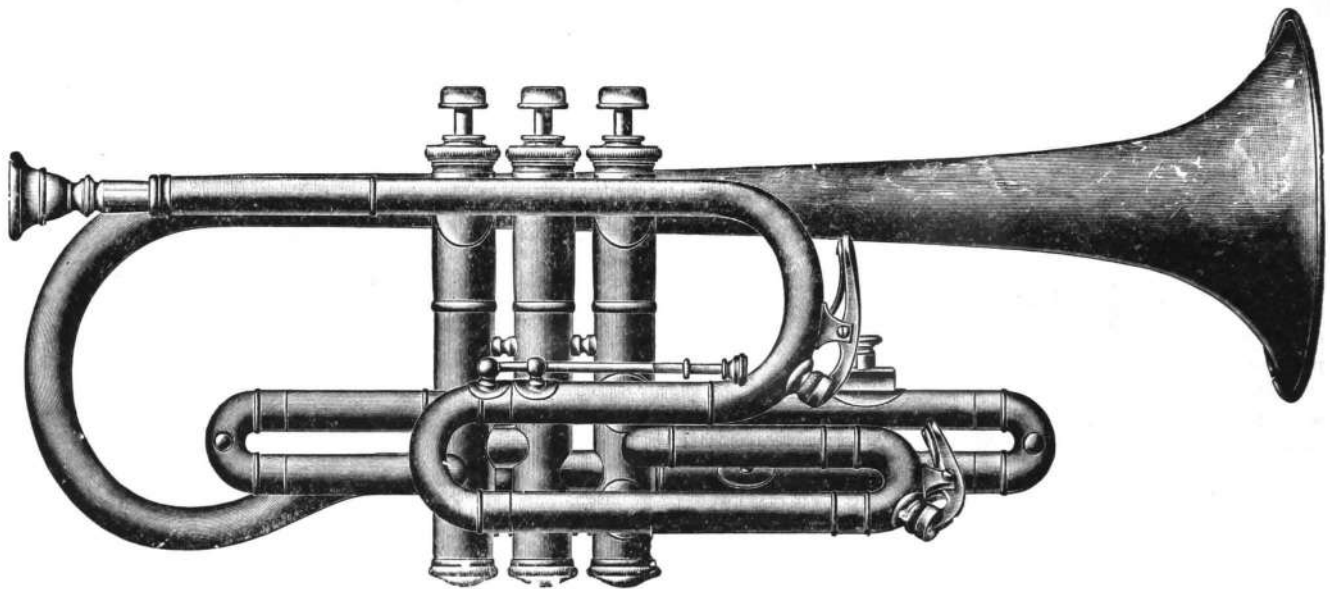

Nos. R260-R260SB

In this instrument we offer a high-grade Cornet of the latest design at a very moderate price. It is splendidly balanced, has a good valve action and is equipped with a quick change attachment from B_b to A. Note the continuous mouthpipe branch—no shanks required. Large bore. Free blowing. Pearl inlaid finger buttons. Furnished with mouthpiece and music lyre.

No.	Each
R260 —Best quality brass, highly polished.....	\$14.00
R260N —Same, nickel plated	16.00
R260SF —Same, triple silver plated, rich satin finish, inside of bell highly burnished	20.50
R260SB —Same, triple silver plated, highly burnished throughout.....	22.00

Burnished gold plating inside of bell \$3.00 extra.

Black or russet solid sole leather satchel, nicely embossed, flannel lined, for the above cornet, \$4.00. Green felt bag, \$0.60.

JEAN MARBEAU SILVER PISTON BAND INSTRUMENTS

Latest American Models. Short, Light Action. Easy Blowing. Correct Scale

HIGH AND LOW PITCH

B \flat CORNET

COURTOIS MODEL

DOUBLE WATER KEY

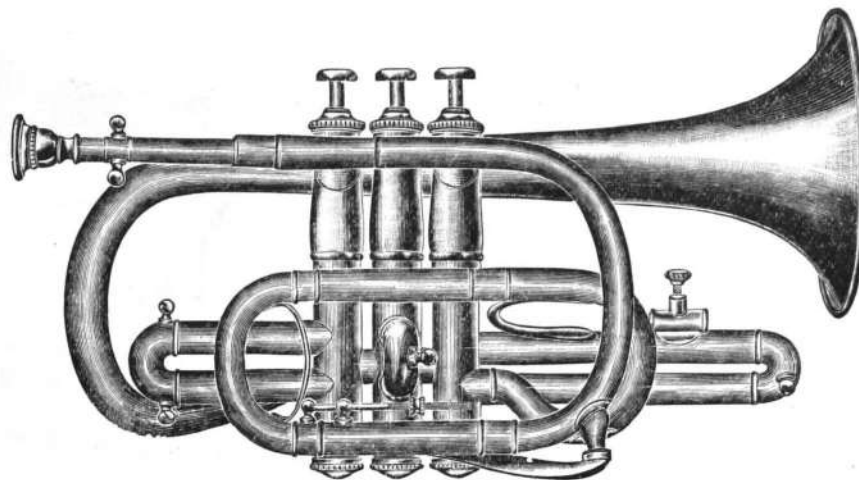

Nos. R220-R220SB

This popularly priced high-grade Courtois Model Cornet is fitted with Rod and Button Low Pitch Device located where it is out of the way of the fingers when playing.

Free air passage of liberal bore, making an easy-blowing, full-toned Cornet.

Each instrument furnished with B \flat and A shanks, mouthpiece and music lyre.

No.	Each
R220 —Best quality brass, highly polished.....	\$14.00
R220N —Same, nickel plated	16.00
R220SF—Same, triple silver plated, rich satin finish, inside of bell highly burnished	20.50
R220SB—Same, triple silver plated, highly burnished throughout	22.00

Burnished gold plating inside of bell \$3.00 extra.

B \flat CORNET, HANDSOMELY ENGRAVED COURTOIS "PROFESSIONAL" MODEL

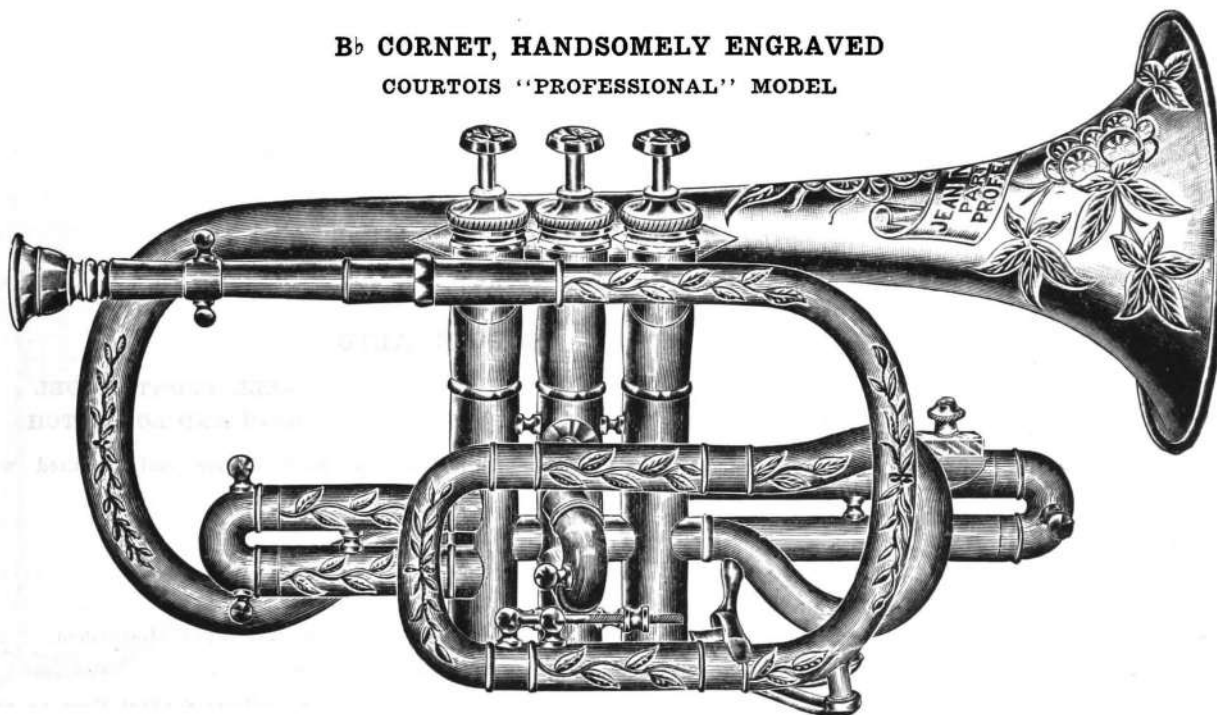

Nos. R221—R221SB

Furnished with attachment for Low Pitch, B \flat and A shanks, mouthpiece and music lyre

No.	Each
R221 —Best quality brass, highly polished and handsomely engraved	\$20.00
R221N —Same, nickel plated, handsomely engraved.....	22.00
R221SF—Same, triple silver plated, rich satin finish, handsomely engraved, inside of bell highly burnished.....	26.50
R221SB—Same, triple silver plated, highly burnished throughout, handsomely engraved	28.00

Burnished gold plating inside of bell, \$3.00 extra

JEAN MARBEAU SILVER PISTON BAND INSTRUMENTS

Latest American Models. Short, Light Action. Easy Blowing. Correct Scale.

HIGH AND LOW PITCH

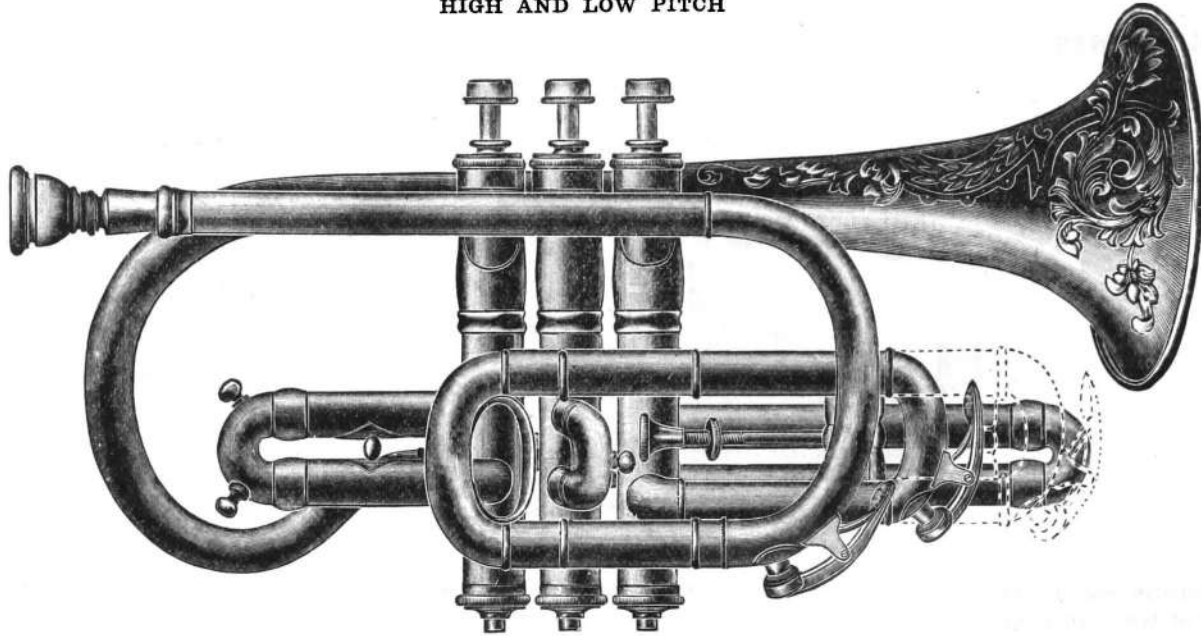

B_b AND A CORNET

JEAN MARBEAU "ARTIST" MODEL

Sole leather Satchel to fit, \$3.75

A splendid leather, silk and plush lined case, \$8.50

This is a superior instrument, of perfect scale and fine valve action. It has a beautifully engraved bell and is equipped with an instantaneous change attachment from B_b to A or vice versa. No shanks are required, the continuous mouthpipe branch obviating the necessity for these. The finger buttons have milled edges and are inlaid with pearl. A beautiful model, very easy blowing, and one of our most popular instruments. An extra slide is included for Low Pitch, also a silver-plated mouthpiece and a music lyre.

No.		Each
R250	—Best quality brass, highly polished, beautifully engraved bell	\$24.00
R250N	—Same, nickel plated, beautifully engraved bell.....	26.00
R250SF	—Same, triple silver plated, rich satin finish, bell beautifully engraved and highly burnished inside.....	30.50
R250SB	—Same, triple silver plated, highly burnished throughout, bell beautifully engraved	32.00

Burnished gold plating inside of bell, \$3.00 extra

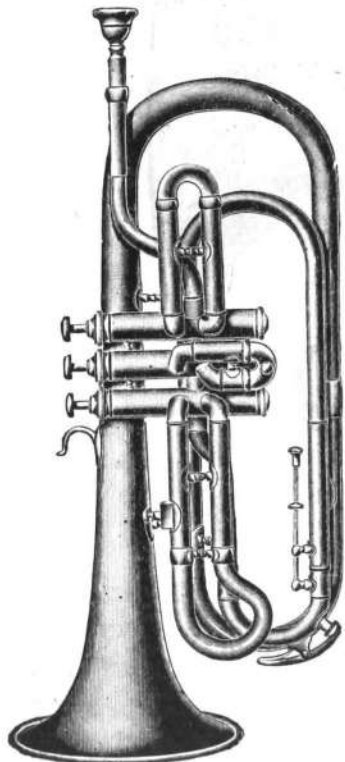

Nos. R206—R206SB
Solo E_b Alto

SOLO E_b ALTO

CORNET SHAPE
NEW AMERICAN MODEL

BELL FRONT MODEL
HIGH AND LOW PITCH

Each instrument equipped with rod and button low pitch device and supplied with music rack and mouthpiece.

No.		Each
R206	—Best quality brass, highly polished.....	\$17.50
R206N	—Same, nickel plated	21.00
R206SF	—Same, triple silver plated, rich satin finish, inside of bell highly burnished.....	26.00
R206SB	—Same, triple silver plated, highly burnished throughout	28.50

Burnished gold plating inside of bell, \$4.00 extra Fine Sole Leather Satchel Case to fit, \$4.50

Write for Special Offer on Complete Sets of Jean Marbeau Band Instruments.
See page 6 for shipping weights.

JEAN MARBEAU SILVER PISTON BAND INSTRUMENTS

Latest American Models. Short, Light Action. Easy Blowing. Correct Scale
HIGH AND LOW PITCH

E_b ALTO—UPRIGHT PATTERN

New American Model. High and Low Pitch

A compactly and gracefully built Alto with a good big clear bore, considerably larger than most other Altos of similar price. The action is short and light, the German-silver pistons being accurately fitted, and the tone is full, rich and round and very easily produced. The tuning slide draws to Low Pitch and is equipped with substantial rod and button device for the purpose. Furnished with mouthpiece and music lyre.

No.	Each
R204 —Best quality brass, highly polished.....	\$17.50
R204N —Same, nickel plated	21.00
R204SF—Same, triple silver plated, rich satin finish, inside of bell highly burnished	26.00
R204SB—Same, triple silver plated, highly burnished throughout.....	28.50

Burnished gold plating inside of bell, \$4.00 extra

Green Felt Bag to fit, \$1.00 Sole Leather End Opening Case, \$9.00

Splendid Plush-lined Side-opening Seal Grain Leather Case, \$12.50

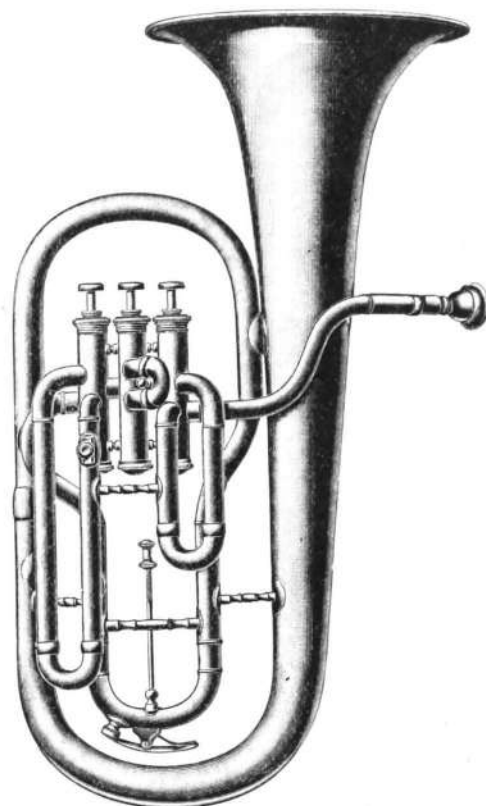

Nos. R204—R204SB E_b Altos



Nos. R208—R208SB B_b Tenors

B_b TENOR

New American Model High and Low Pitch

Furnished with mouthpiece and music lyre. Tuning slide of sufficient length to draw to Low Pitch and equipped with substantial rod and button device. A Tenor of liberal bore possessing the real tenor quality of tone. Very substantially made throughout—observe the numerous braces.

No.	Each
R208 —Best quality brass, highly polished.....	\$20.00
R208N —Same, nickel plated	24.50
R208SF—Same, triple silver plated, rich satin finish, inside of bell highly burnished	30.00
R208SB—Same, triple silver plated, highly burnished throughout.....	32.50

Burnished gold plating inside of bell, \$5.00 extra

Green Felt Bag to fit, \$1.10 Fine Sole Leather Case, \$9.50

JEAN MARBEAU SILVER PISTON BAND INSTRUMENTS

Latest American Models. Short, Light Action. Easy Blowing. Correct Scale
HIGH AND LOW PITCH

B \flat TENOR VALVE TROMBONE

LONG PATTERN

New American Model High and Low Pitch

The best low-priced Valve Trombone on the market. The model is the latest up-to-date long pattern used by the best American makers and the playing qualities will be an agreeable surprise. It has a 7½-inch bell (the cut is a little out of proportion), German silver pistons accurately ground into the casings, is of strikingly big tone and very correct in intonation. The tuning slide draws to Low Pitch and is equipped with the rod and button device used on all Marbeau instruments. Furnished with mouthpiece and music lyre.

No.	Each
R209 —Best quality brass, highly polished.....	\$20.00
R209N —Same, nickel plated	25.00
R209SF—Same, triple silver plated, rich satin finish, inside of bell highly burnished.....	31.00
R209SB—Same, triple silver plated, highly burnished throughout	34.00
Burnished gold plating inside of bell, \$4.00 extra	
Green Felt Bag to fit, \$1.25	Sole Leather End-opening Case, \$9.00
Fine Side-opening, Plush-lined Seal Grain Leather Case, \$12.50	



Nos. R209—R209SB
B \flat Tenor Valve
Trombones

B \flat TENOR SLIDE TROMBONE

New American Model High and Low Pitch

A well-balanced Trombone with the best slide action of any instrument on the market at the price. The German silver stockings are the same length as in the finest American makes, giving plenty of bearing surface, thereby decreasing the wear and adding to the smoothness of operation. The bell is 7½ inches in diameter. The instrument is medium large bore producing a big, snappy tone. Built in High Pitch with slide drawing to Low Pitch. Mouthpiece and music lyre included.

No.	Each
R207 —Best quality brass, highly polished.....	\$16.00
R207N —Same, nickel plated	19.00
R207SF—Same, triple silver plated, rich satin finish, inside of bell highly burnished.....	23.50
R207SB—Same, triple silver plated, highly burnished throughout	26.00
Burnished gold plating inside of bell, \$4.00 extra	
Green Felt Bag to fit, \$1.35	Sole Leather End-opening Case, \$8.50
Fine Side-opening Plush-lined Seal Grain Leather Case, \$12.00	

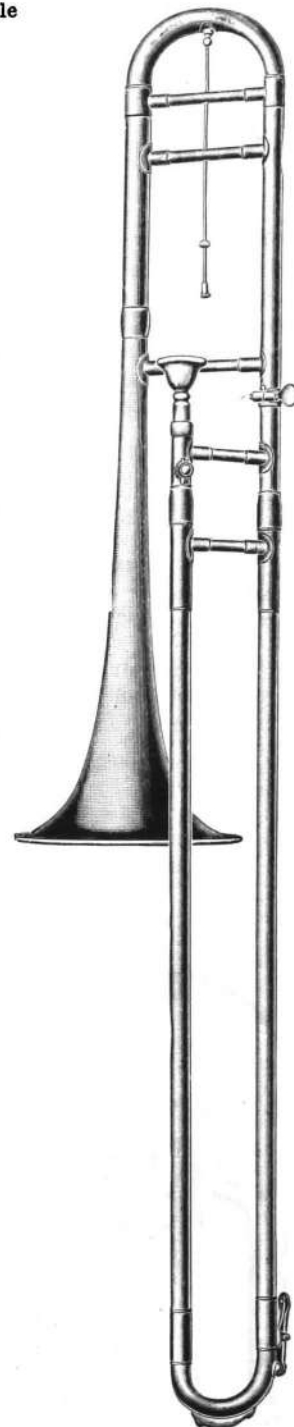

Nos. R207—R207SB
B \flat Tenor Slide
Trombones

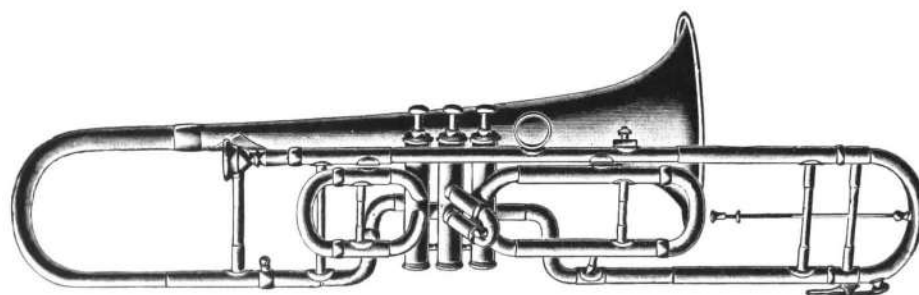

Nos. R205—R205SB E \flat Alto Valve Trombones

E \flat ALTO VALVE TROMBONE

New American Model Graceful Design
High and Low Pitch

No.	Each
R205 —Best quality brass, highly polished	\$17.50
R205N —Same, nickel plated.....	21.00
R205SF—Same, triple silver plated, rich satin finish, inside of bell highly burnished	26.00
R205SB—Same, triple silver plated, highly burnished throughout	28.50
Burnished gold plating inside of bell, \$4.00 extra. Sole Leather End-opening Case, \$9.00	

JEAN MARBEAU SILVER PISTON BAND INSTRUMENTS

Latest American Models. Short, Light Action. Easy Blowing. Correct Scale
HIGH AND LOW PITCH

B \flat BARITONE

New American Model High and Low Pitch

A compactly modeled Baritone of large bore and substantial construction which is guaranteed to give satisfaction at the price. The tone is full and round and easily produced, the scale well in tune. Light, short action German silver pistons. Tuning slide draws to Low Pitch and is provided with rod and button device. Mouthpiece and music lyre are included.

No.	Each
R210 —Best quality brass, highly polished.....	\$25.00
R210N —Same, nickel plated	30.00
R210SF—Same, triple silver plated, rich satin finish, inside of bell highly burnished	37.50
R210SB—Same, triple silver plated, highly burnished throughout....	41.50
Burnished gold plating inside of bell, \$5.00 extra	
Green Felt Bag to fit, \$1.25	End-opening Sole Leather Case, \$11.00
Fine Side-opening Plush-lined Seal Grain Leather Case, \$15.00	



Nos. R210—R210SB B \flat
Baritones



Nos. R212—R212SB B \flat Basses

B \flat BASS

New American Model High and Low Pitch

Of the same general model and description as the Baritone, this Horn is built in a larger size and heavier bore, resulting in a greater volume of tone. It can, in fact, be used as a Baritone with excellent effect in the larger organizations where a heavier, bigger tone is required. As in all other Marbeau instruments the tuning slide pulls to Low Pitch and is equipped with rod and button device. Mouthpiece and music rack are included.

No.	Each
R212 —Best quality brass, highly polished.....	\$27.50
R212N —Same, nickel plated	33.50
R212SF—Same, triple silver plated, rich satin finish, inside of bell highly burnished	45.00
R212SB—Same, triple silver plated, highly burnished throughout...	50.00
Burnished gold plating inside of bell, \$6.00 extra	
Green Felt Bag to fit, \$1.40	End-opening Sole Leather Case, \$12.00

JEAN MARBEAU SILVER PISTON BAND INSTRUMENTS

Latest American Models. Short, Light Action. Easy Blowing. Correct Scale. High and Low Pitch

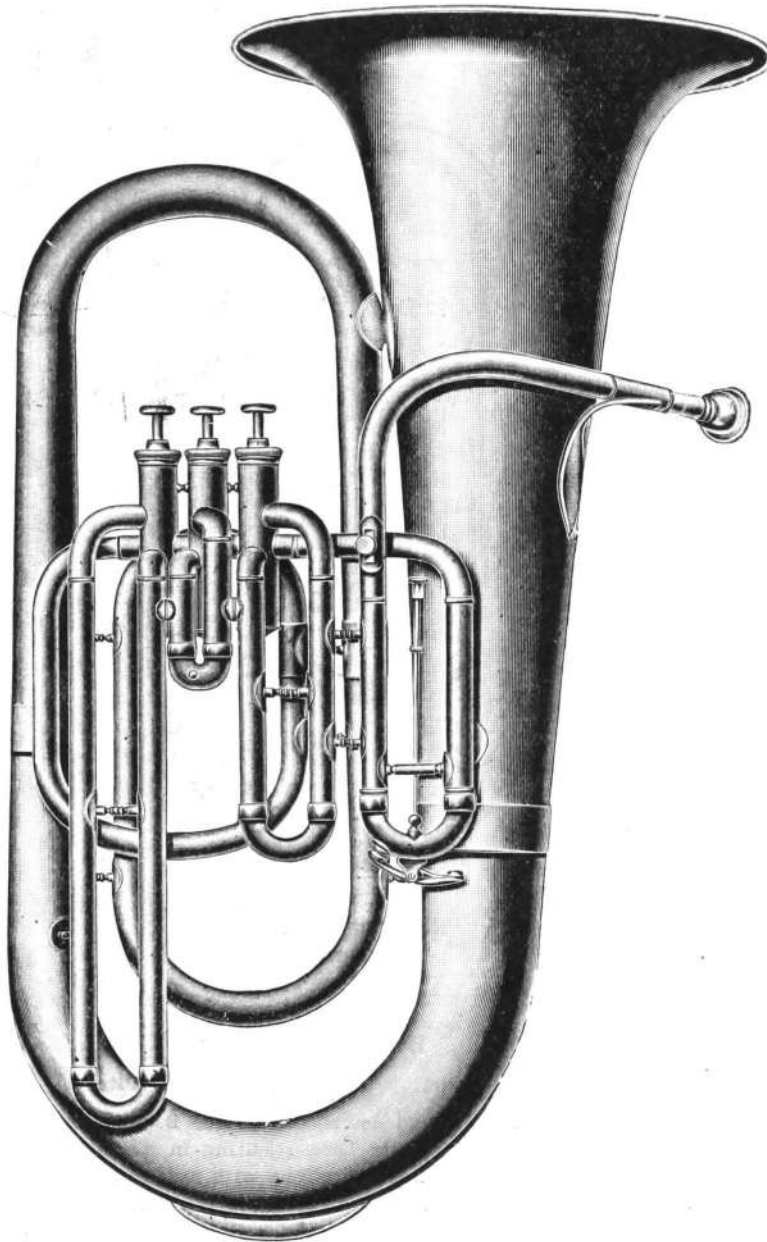

Nos. R214—R214SB E♭ Basses

E♭ BASS
Upright Pattern

NEW AMERICAN MODEL
High and Low Pitch

A strongly and compactly built Bass of large bore which will stand a lot of hard treatment and give splendid satisfaction at the price. Big, sonorous tone easily produced. Tuning slide long enough for Low Pitch. Mouthpiece and music lyre included.

No.	Each
R214 —Best quality brass, highly polished.....	\$36.00
R214N —Same, nickel plated	43.50
R214SF—Same, triple silver plated, rich satin finish, inside of bell highly burnished	56.00
R214SB—Same, triple silver plated, highly burnished throughout.....	62.00
Burnished gold plating inside of bell, \$8.00 extra	
Green Felt Bag to fit, \$1.50	End-opening Sole Leather Case, \$17.50

For nearly a quarter of a century we have been equipping bands with Jean Marbeau Instruments, always with the greatest satisfaction, and during all that time this renowned make has been kept abreast of the times and ahead of competitors by a progressive policy in adopting all that is best and up to date in band instrument construction.

JEAN MARBEAU SILVER PISTON BAND INSTRUMENTS

Latest American Models. Short, Light Action. Easy Blowing. Correct Scale. High and Low Pitch



Notice how substantially all Jean Marbeau instruments are braced. In many other makes sold at similar prices, the instruments are merely held together by soldering one part of the tubing to another.

Nos. R215—R215SB E_b Bases, Helicon Model

In the Jean Marbeau Helicon Bass we offer an instrument of immense tone power, easy of production because of the lack of twists and turns in the tubing. Its graceful circular shape makes it particularly easy to handle in street work, as it fits nicely around the body of the player and is carried practically without effort. The action is light, short and conveniently located. Furnished with a set of extra Low Pitch tubes, mouthpiece and music lyre.

No.	Each
R215 —Best quality brass, highly polished.....	\$55.00
R215N —Same, nickel plated	62.50
R215SF—Same, triple silver plated, rich satin finish, inside of bell highly burnished	75.00
R215SB—Same, triple silver plated, highly burnished throughout.....	81.00

Burnished gold plating inside of bell, \$7.00 extra

Write for Special Offer on Complete Sets of Jean Marbeau Band Instruments. Ten days trial allowed on all Band Instruments. Your money cheerfully refunded if not satisfactory.

COUESNON & CIE. BAND INSTRUMENTS

Manufactured by
COUESNON & CIE.

No. 94 Rue d'Angouleme

Paris, France

Purveyors by appointment to the famous band of the Republican Guard.
Purveyors by appointment to the War and Navy offices of France.
Purveyors by appointment to the Department of Fine Arts of France.
1893—Paris. Knight of the Legion of Honour.
1900—Paris, Universal Exposition—Hors Concours, Member of the Jury of Awards.

1844—Paris National Exposition, silver medal.
1849—Paris National Exposition, silver medal.
1851—London International Exposition, silver medal.
1855—Paris Universal Exposition, gold medal.
1855—Paris Universal Exposition, silver medal.
1865—Porto International Exposition, gold medal.

1867—Paris Universal Exposition, gold medal.
1869—Amsterdam International Exposition, gold medal.
1873—Vienna Universal Exposition, medal for progress.
1882—Lille International Exposition, prize medal.
1887—Hanoi National Exposition, prize medal.
1889—Paris Universal Exposition, gold medal.

Medals and
Honors
received
by
Couesnon
& Cie.,
successors
to
Gautrot, Ainé
& Cie.



Couesnon
& Cie.
recently
secured
a contract
to supply
the French
army with
3672
instruments.

**COUESNON INSTRUMENTS OFFER THE GREATEST VALUES IN THE WORLD FOR THE
LEAST MONEY. THERE ARE THREE GOOD REASONS:**

- 1—Couesnon & Cie. have been making Band Instruments for upwards of a hundred years. They have forgotten more than most other manufacturers know about the industry.
- 2—A stupendous production drives their manufacturing costs down to the lowest possible figure. One thousand workmen, the best obtainable, are employed in their three factories.
- 3—Unlike the smaller makers, who must ask a large margin of profit on a small output, they can well afford to be content with an exceedingly small percentage over cost, and the enormous volume of their business brings them adequate returns.

**THE RESULT IS THAT COUESNON BAND INSTRUMENTS ARE SOLD TO THE CONSUMER
AT 25 PER CENT LESS THAN THE PRICES OF OTHER MAKES OF SIMILAR QUALITY**

See Historical Sketch of the House of Couesnon on page 60.

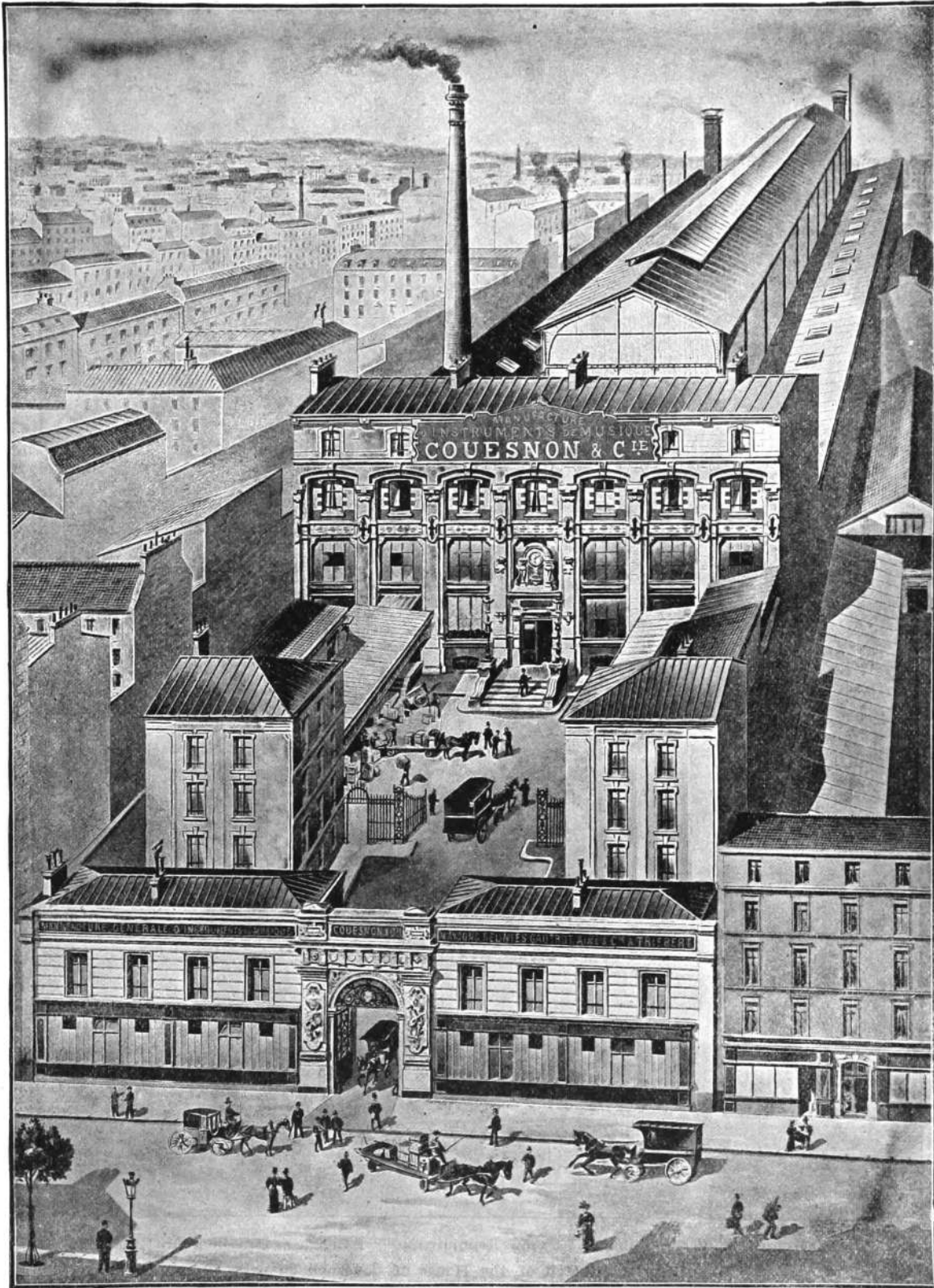
COUESNON & CIE. BAND INSTRUMENTS

Couesnon & Cie. maintain factories at Paris, Chateau-Thierry and Garennes, in which they employ almost a thousand workmen. The above is a general view of the Paris plant.

COUESNON & CIE. BAND INSTRUMENTS

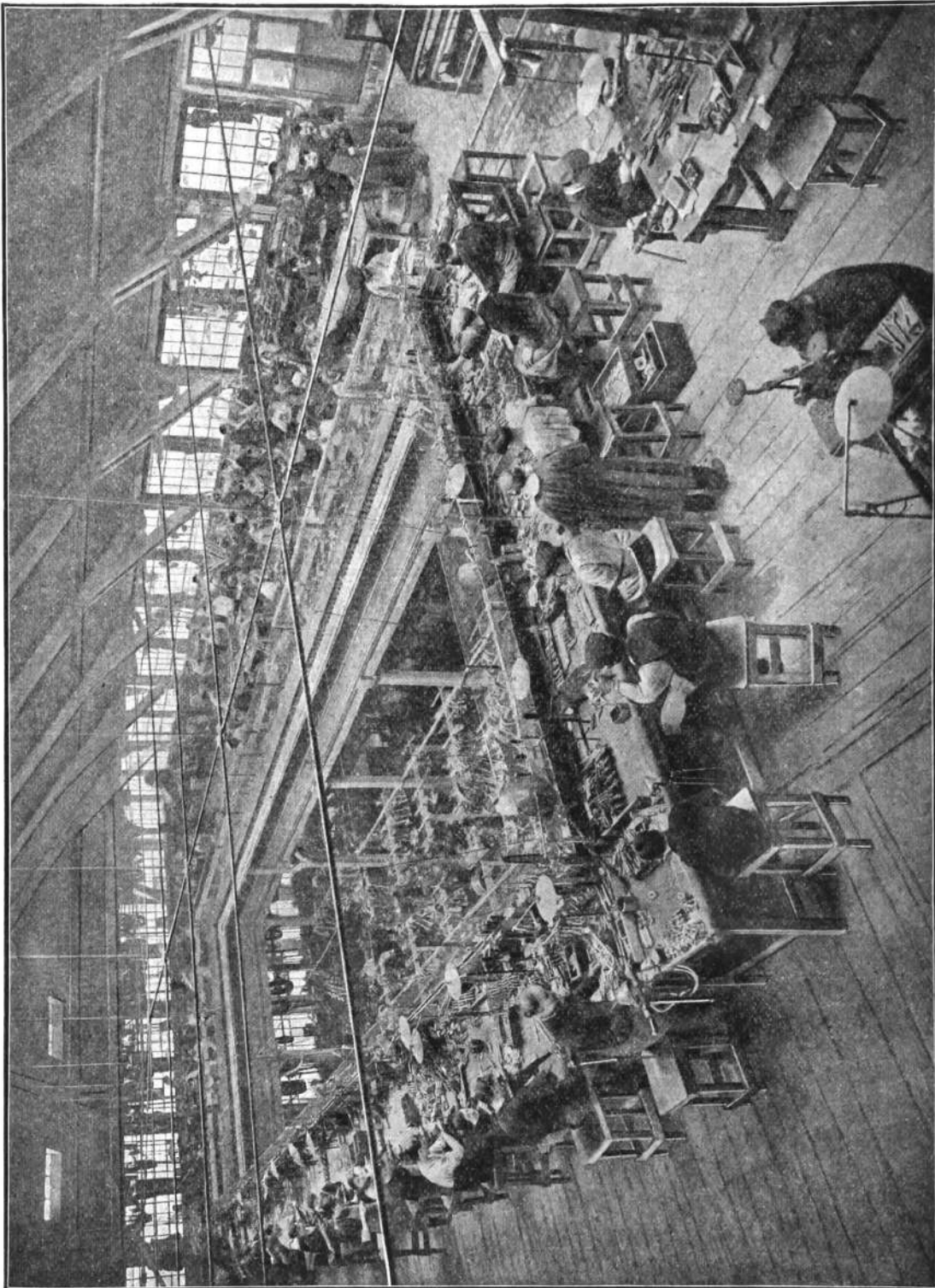

General view of the upper floor and a portion of the lower floor of the Chateau-Thierry factory.

All the Soloists of the famous "Garde Republicaine" Band use Couesnon Instruments.
See Historical Sketch of the House of Couesnon on page 60.

COUESNON & CIE. BAND INSTRUMENTS

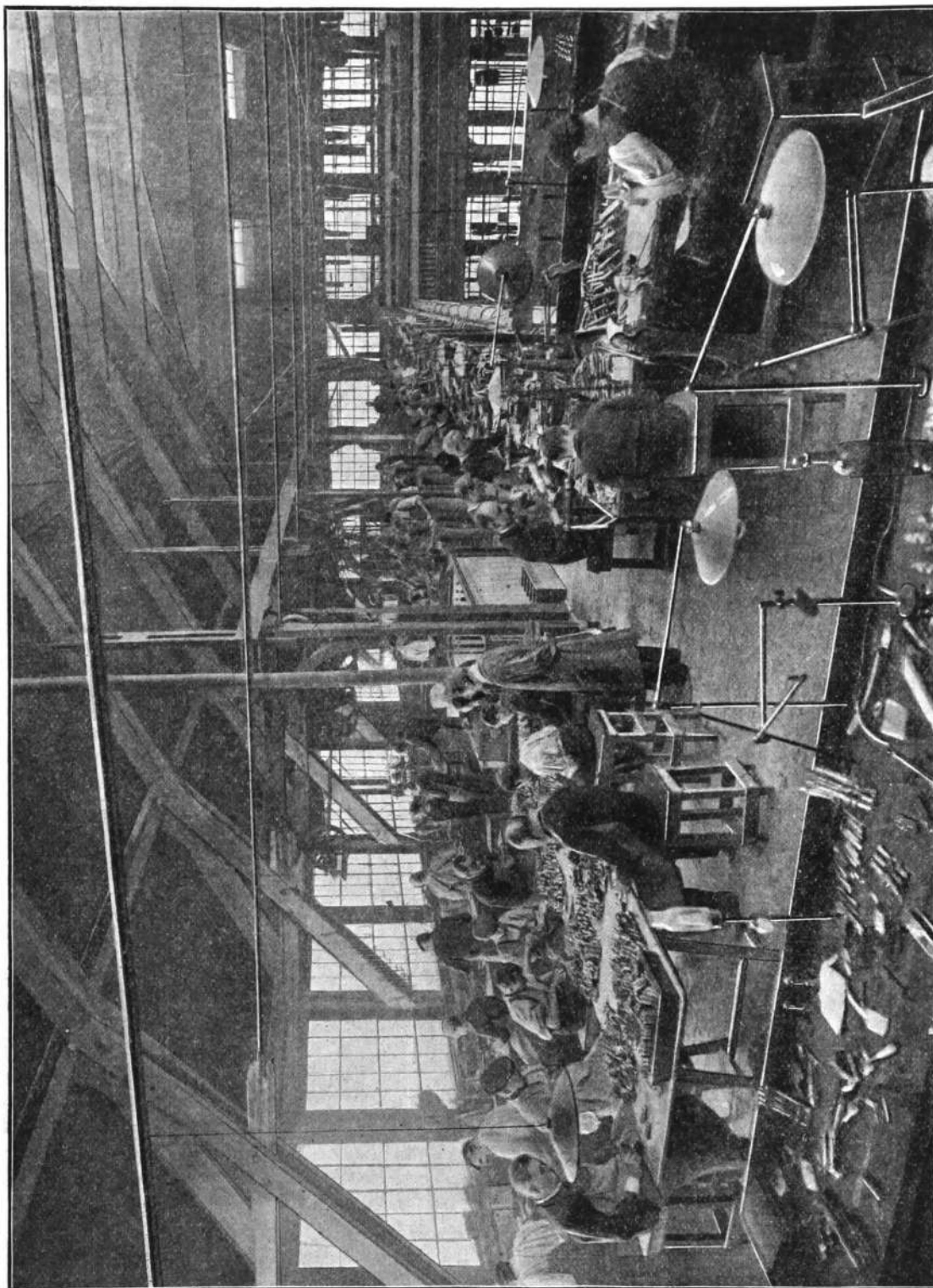

View of valve-making department in Couesnon & Cie.'s Chateau-Thierry factory.

Couesnon & Cie. were recently awarded a contract to supply the French army with 3672 instruments.

COUESNON & CIE. 20th CENTURY BAND INSTRUMENTS

IMMEASURABLY SUPERIOR TO ALL OTHERS AT SIMILAR PRICES

EVERY COUESNON INSTRUMENT IS EQUIPPED WITH PEARL TOP KEY BUTTONS, AND IS FURNISHED WITH LOW PITCH ATTACHMENT, SILVER PLATED MOUTHPIECE AND MUSIC RACK

E^b CORNET

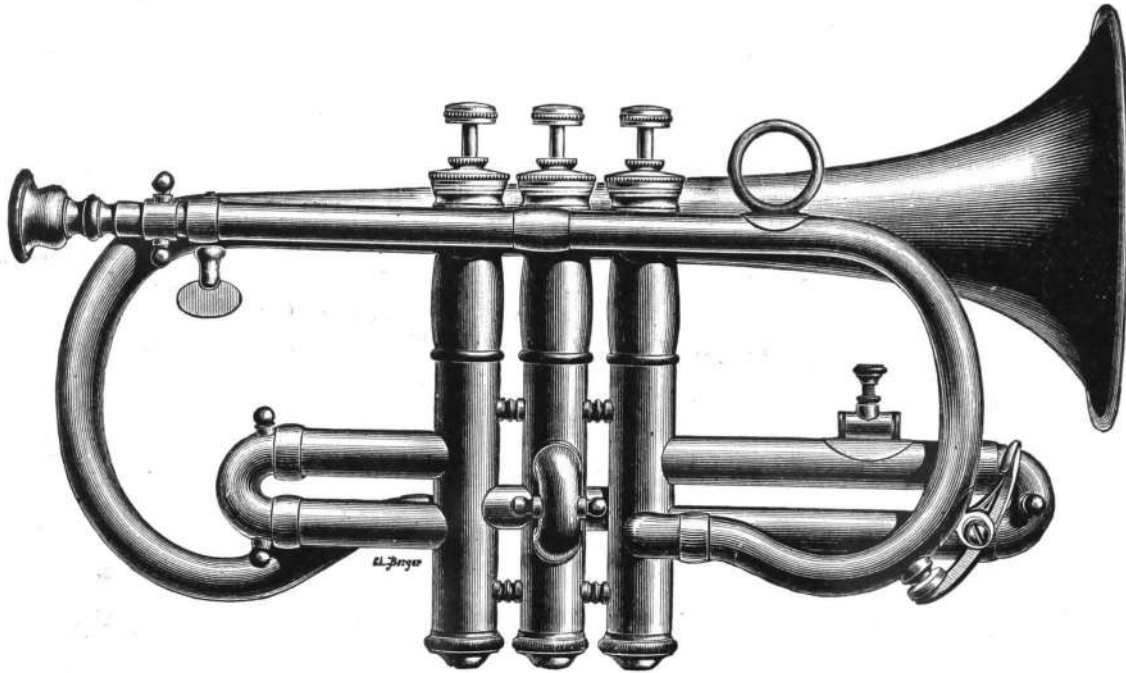

No.	Each
R340 —Best quality brass, highly polished.....	\$12.50
R340N—Same, nickel plated	14.50
R340B—Same, triple silver plated, rich satin finish, inside of bell highly burnished	19.00
R340C—Same, triple silver plated, highly burnished throughout.....	20.50

Burnished gold plating inside of bell, \$3.00 extra.

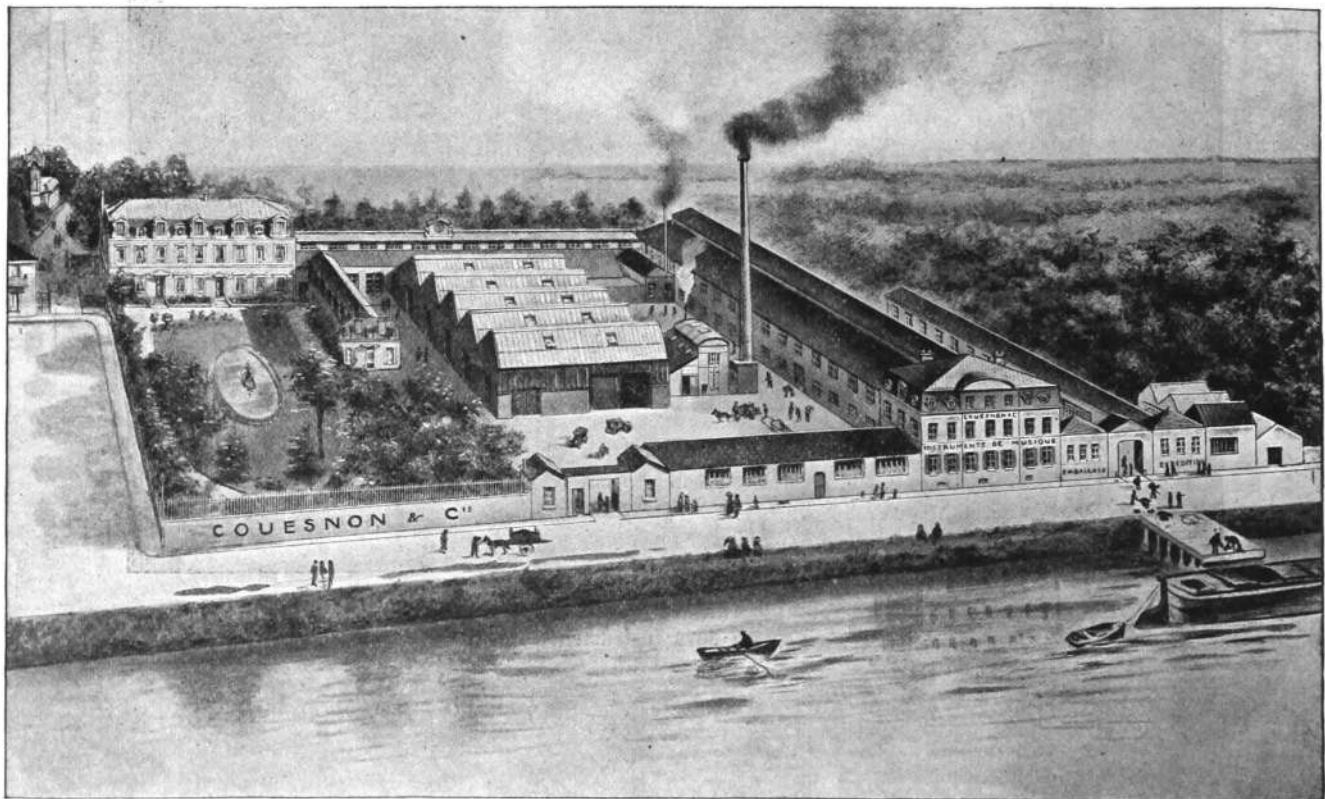

The Couesnon & Cie. factory at Chateau-Thierry.

COUESNON & CIE. 20th CENTURY BAND INSTRUMENTS

IMMEASURABLY SUPERIOR TO ALL OTHERS AT SIMILAR PRICES

New Graceful Models. Easy Blowing. Accurate Scale. Light Free Action. Excellent Tone. Pearl Top Finger Buttons. Silver Plated Mouthpiece.

B \flat CORNET

High and Low Pitch.

Single Water Key.

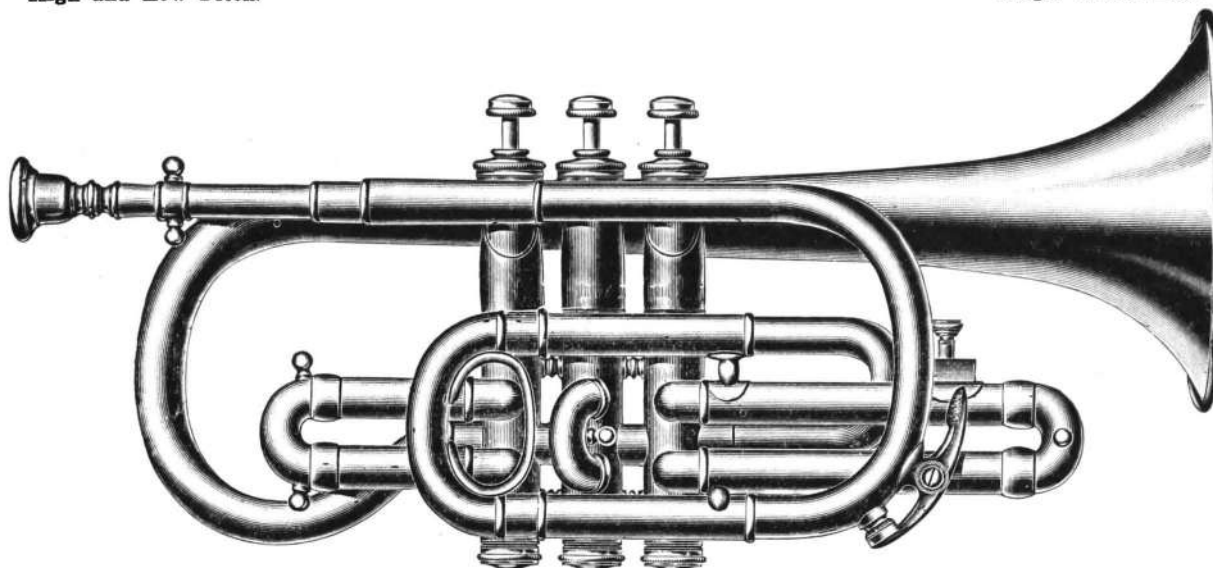

Furnished with B \flat and A Set Pieces, Silver Plated Mouthpiece and Music Lyre. Pearl Top Finger Buttons.

No.	Each
R342 —Best quality brass, highly polished.....	\$15.00
R342N—Same, nickel plated	17.00
R342E—Same, triple silver plated, rich satin finish, inside of bell highly burnished	21.50
R342C—Same, triple silver plated, highly burnished throughout.....	23.00

Burnished gold plating inside of bell, \$3.00 extra.

B \flat CORNET—LONG MODEL OR TRUMPET FORM

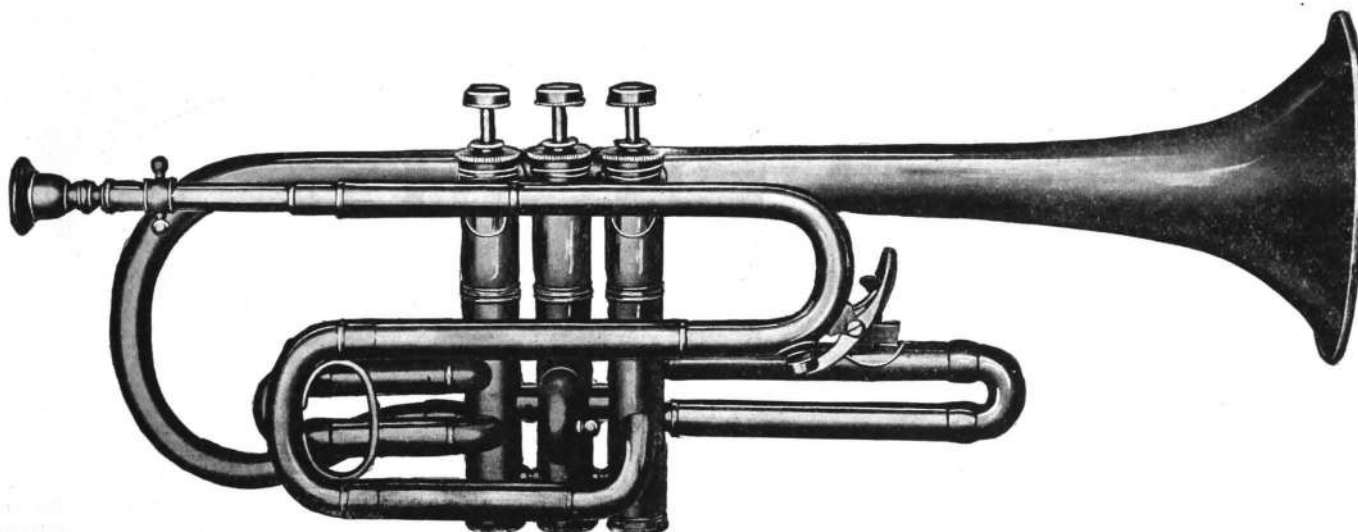

Equipped with slide for quick change to A at first turn of mouthpipe tubing. Low pitch slide has set screw to fasten in correct position. Furnished with silver plated mouthpiece and music lyre. Pearl top finger buttons.

No.	Each
R343 —Best quality brass, highly polished.....	\$17.50
R343N—Same, nickel plated	19.50
R343E—Same, triple silver plated, rich satin finish, inside of bell highly burnished	24.00
R343C—Same, triple silver plated, highly burnished throughout.....	25.50

Burnished gold plating inside of bell, \$3.00 extra.

COUESNON & CIE. 20th CENTURY BAND INSTRUMENTS

IMMEASURABLY SUPERIOR TO ALL OTHERS AT SIMILAR PRICES

New Graceful Models. Easy Blowing. Accurate Scale. Light Free Action. Excellent Tone. Pearl Top Finger Buttons. Silver Plated Mouthpiece.

B^b CORNET

Courtois Model. Double Water Key.

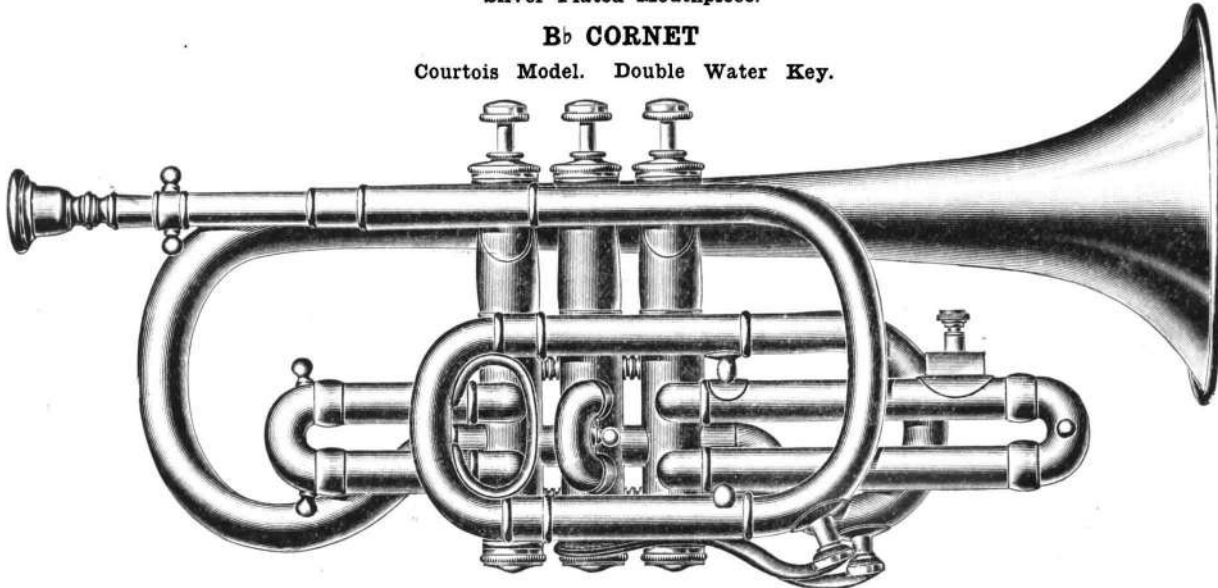

Furnished with B^b and A Set Pieces, Silver Plated Mouthpiece and Music Lyre. Pearl Top Key Buttons.

No.		Each
R344	—Best quality brass, highly polished.....	\$20.00
R344N	—Same, nickel plated	22.00
R344B	—Same, triple silver plated, rich satin finish, inside of bell highly burnished	26.50
R344C	—Same, triple silver plated, highly burnished throughout.....	28.00

Burnished gold plating inside of bell, \$3.00 extra.

PROFESSIONAL MODEL B^b CORNET

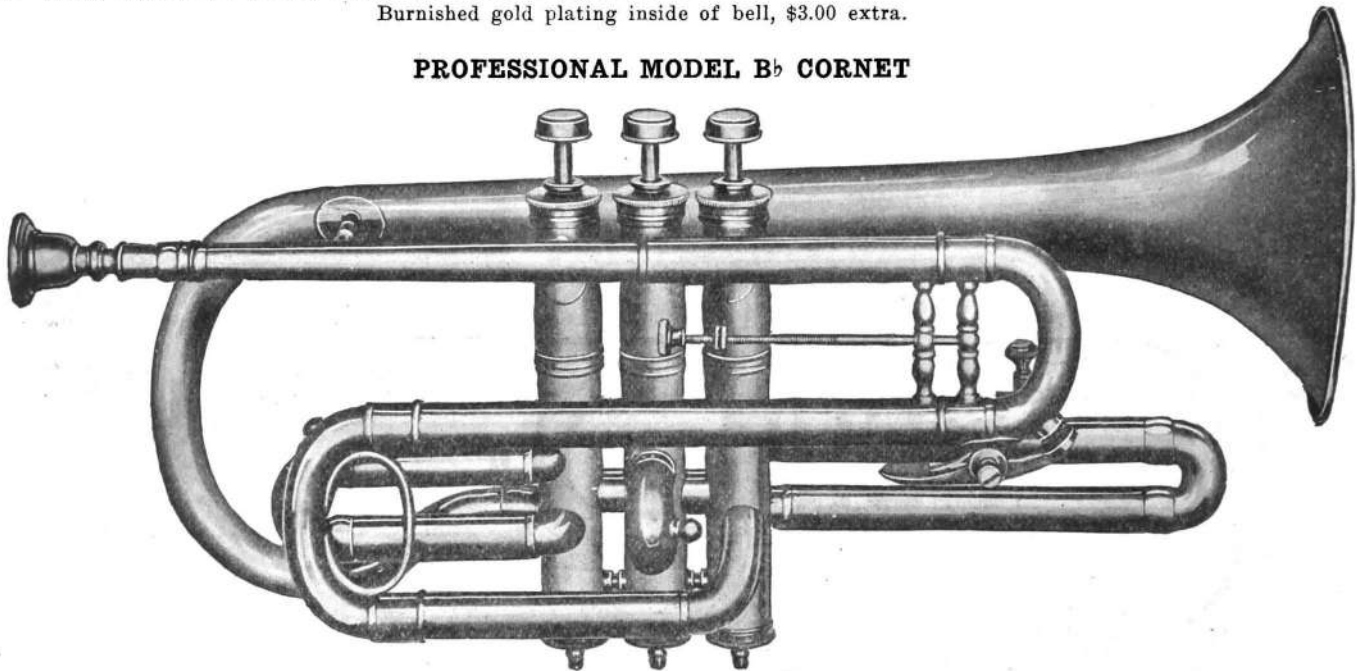

This popular Cornet, patterned after the best American makes, is of medium long model and is a remarkable instrument for the money. It is built in B^b with instantaneous change to A—No shanks required. German silver pistons, pearl inlaid valve buttons. Built in High Pitch with tuning slide of sufficient length to draw to Low Pitch. The bore of the tubing is large and the arrangement such as to secure an unobstructed air passage, resulting in a very free blowing, big toned instrument. Silver plated mouthpiece and music lyre included.

No.		Each
R345	—Best quality brass, highly polished.....	\$20.00
R345N	—Same, nickel plated	22.00
R345B	—Same, triple silver plated, rich satin finish, inside of bell highly burnished	26.50
R345C	—Same, triple silver plated, highly burnished throughout.....	28.00

Burnished gold plating inside of bell, \$3.00 extra.

For Satchels and Cases to fit above Cornets, see page 49.

Couesnon Band Instruments have been manufactured for upwards of a hundred years, are used by the thousand throughout Europe and enjoy a reputation second to none.

COUESNON & CIE. 20th CENTURY BAND INSTRUMENTS

IMMEASURABLY SUPERIOR TO ALL OTHERS AT SIMILAR PRICES
 New Graceful Models. Easy Blowing. Accurate Scale. Light Free Action. Excellent Tone. Pearl Top Finger Buttons. Silver Plated Mouthpiece. High and Low Pitch.

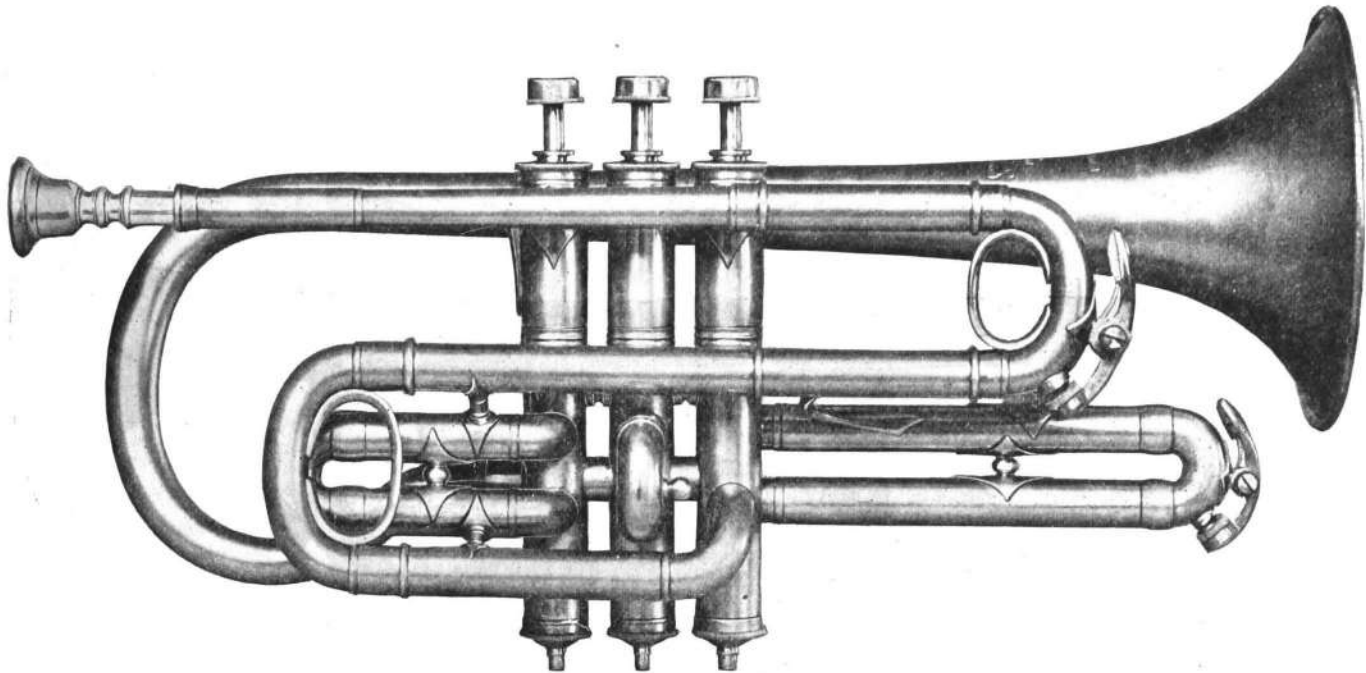

HIPPODROME MODEL CORNET

No. R347

No Sharp Turns

In High and Low Pitch, B_b and A

A very symmetrically modeled instrument copied after one of the favorite American makes. It has the up-to-date Long Bell, is correctly balanced and proportioned and is thoroughly well made down to the smallest details. The quick change to A is at the first bend of the mouthpipe tubing, the Low Pitch tuning slide at the second turn. Fine German silver valves, accurately ground and fitted, insuring ease of blowing. Incased valve action. Pearl inlaid finger buttons. Handsomely engraved bell.

No.	Each
R347 —Best quality brass, highly polished.....	\$22.50
R347N—Same, nickel plated	24.50
R347B—Same, triple silver plated, rich satin finish, inside of bell highly burnished	29.00
R347C—Same, triple silver plated, highly burnished throughout.....	30.50
Burnished gold plating inside of bell, \$3.00 extra.	

B_b CORNET WITH QUICK CHANGE TO A

Perfectly in Tune in Both Keys

High and Low Pitch

No Shanks Required.

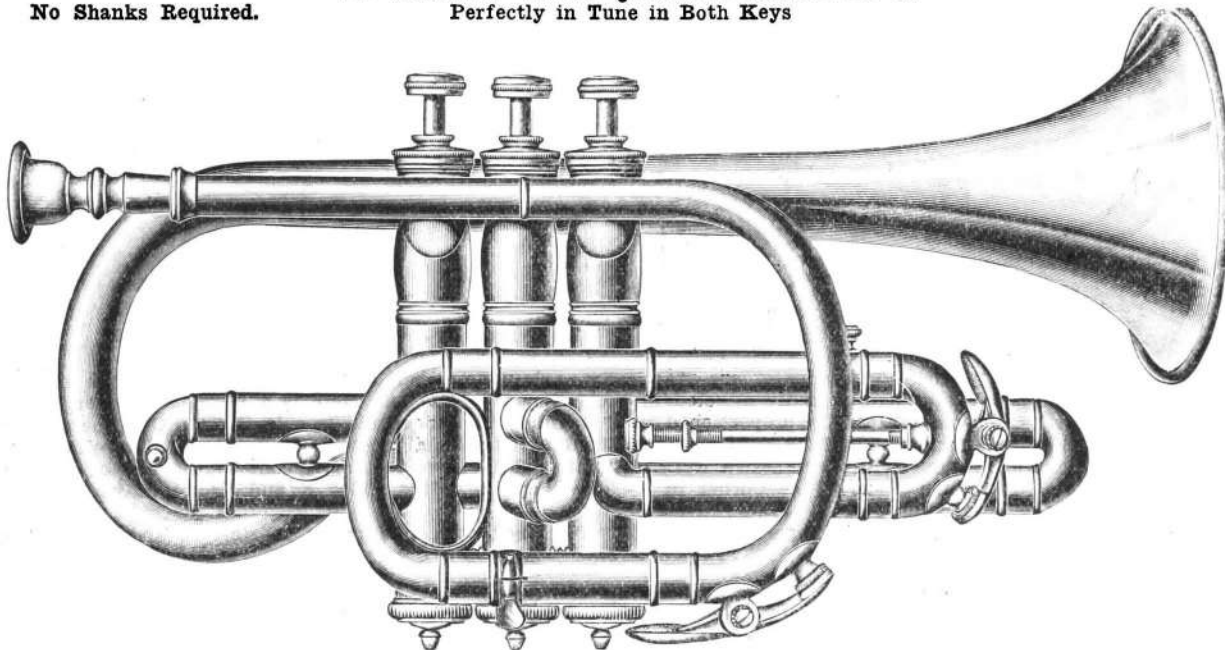

No.	Each
R348 —Best quality brass, highly polished.....	\$22.50
R348N—Same, nickel plated	24.50
R348B—Same, triple silver plated, rich satin finish, inside of bell highly burnished	29.00
R348C—Same, triple silver plated, highly burnished throughout.....	30.50
Burnished gold plating inside of bell, \$3.00 extra.	

We take old instruments in part payment. Send for blank on which to describe your instrument.

COUESNON & CIE. 20th CENTURY BAND INSTRUMENTS

IMMEASURABLY SUPERIOR TO ALL OTHERS AT SIMILAR PRICES

New Graceful Models. Easy Blowing. Accurate Scale. Light Free Action. Excellent Tone. Pearl Top Finger Buttons. Silver Plated Mouthpiece. High and Low Pitch.

C, B_b AND A OR VOCAL CORNET—LONG MODEL

Perfectly in tune in all three keys and both pitches. The ideal Cornet for parlor, church or Sunday School use. Plays vocal, piano or organ music without transposition. Equally suitable for band or orchestra work. Very easy blowing. Long model: Length, 15 inches.

Illustration 1

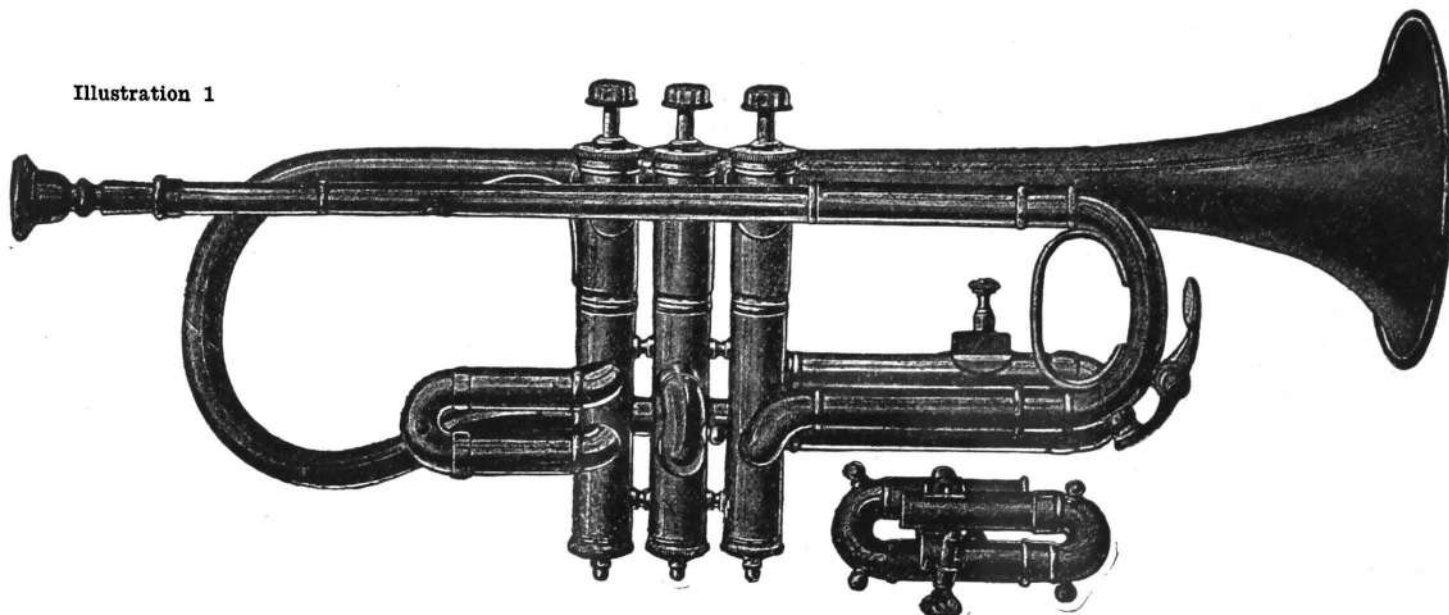
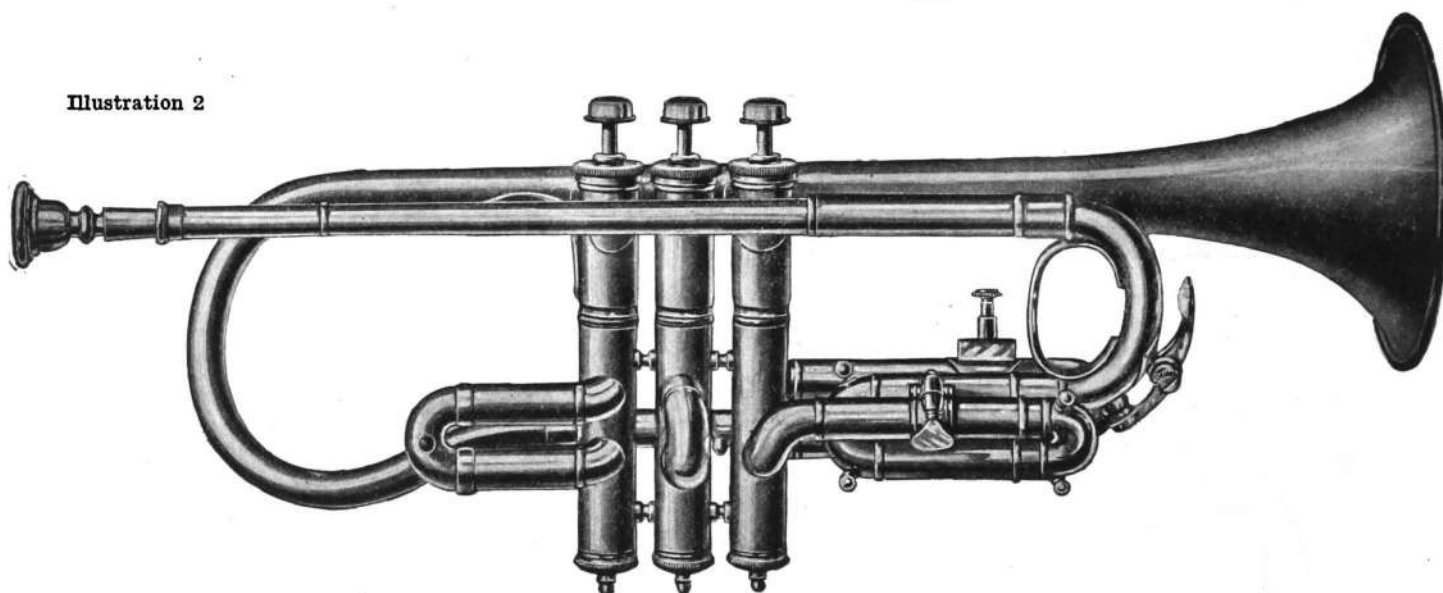

Illustration 2



Most C Cornets are either of freakish appearance or are practically unplayable either because the tone is not free and full in the key of C, or if all right in C, the instrument is badly affected in the keys of B_b and A. Here is a Cornet, however, which is just right from every standpoint. It is very gracefully proportioned in a medium long model and is a legitimate C Cornet which can be played in perfect tune in B_b and A, and in all three keys the instrument will be found easy blowing with a nice solid tone of good carrying power suited for church, home, band or orchestra work. Illustration 1 shows the instrument in the key of C with the B_b and A attachment separate. Illustration 2 shows the Cornet in B_b. To play in A, the slides X and Y are drawn to positions indicated by etched rings on the inner slide.

Every Couesnon Vocal Cornet has pearl inlaid finger buttons and is furnished with mouthpiece, music lyre and a set of extra low pitch sleeves.

No.	Each
R346 —Best quality brass, highly polished.....	\$25.00
R346N—Same, nickel plated	27.00
R346E—Same, triple silver plated, rich satin finish, inside of bell highly burnished	31.50
R346C—Same, triple silver plated, highly burnished throughout.....	33.00

Burnished gold plating inside of bell, \$3.00 extra.

Green Felt Bag for the above Cornets, \$0.60.

Leather Satchels, \$2.50 and \$3.50.

See page 6 for shipping weights.

Couesnon Band Instruments have been adopted by the French Government for its army and navy musicians. They are used by all the soloists of the famous "Garde Republicaine" Band.

COUESNON & CIE. 20th CENTURY BAND INSTRUMENTS

IMMEASURABLY SUPERIOR TO ALL OTHERS AT SIMILAR PRICES

New Graceful Models. Easy Blowing. Accurate Scale. Light Free Action. Excellent Tone. Pearl Top Finger Buttons.
Silver Plated Mouthpiece. High and Low Pitch.

SOLO E^b ALTO

Bell Front Model or Cornet Shape. High and Low Pitch.



Every Couesnon Solo Alto has pearl inlaid finger buttons, finger hook, silver plated mouthpiece, music lyre and extra low pitch sleeves.

No.	Each
R352 —Best quality brass, highly polished.....	\$22.50
R352N—Same, nickel plated	26.00
R352B—Same, triple silver plated, rich satin finish, inside of bell highly burnished	31.00
R352C—Same, triple silver plated, highly burnished throughout.....	33.50

Burnished gold plating inside of bell, \$4.00 extra.

Fine Sole Leather Satchel Case to fit, \$4.50.

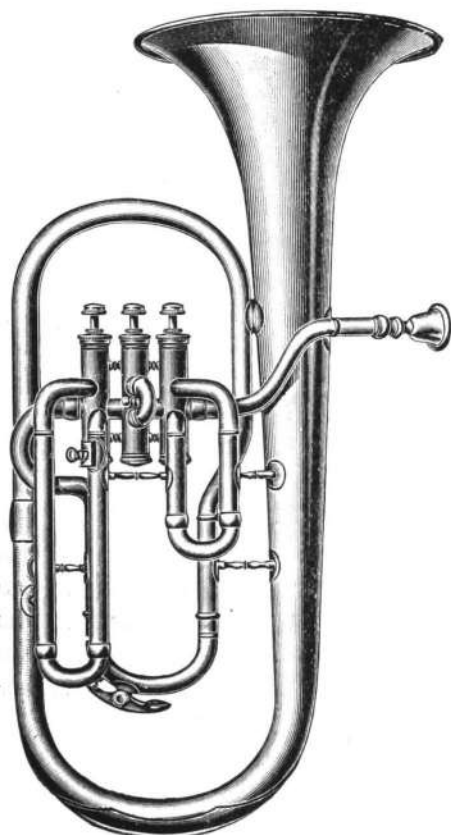

E^b ALTO

UPRIGHT MODEL

HIGH AND LOW PITCH

Furnished with Silver Plated Mouthpiece, Music Lyre and extra Low Pitch Sleeves.

No.	Each
R350 —Best quality brass, highly polished.....	\$22.50
R350N—Same, nickel plated	26.00
R350B—Same, triple silver plated, rich satin finish, inside of bell highly burnished	31.00
R350C—Same, triple silver plated, highly burnished throughout.....	33.50

Burnished gold plating inside of bell, \$4.00 extra.

Green Felt Bag to fit, \$1.00.

Sole Leather End Opening Case, \$9.00.

Splendid Plush Lined Side Opening Leather Case, \$12.50.

COUESNON & CIE. 20th CENTURY BAND INSTRUMENTS

IMMEASURABLY SUPERIOR TO ALL OTHERS AT SIMILAR PRICES

New Graceful Models. Easy Blowing. Accurate Scale. Light Free Action. Excellent Tone. Pearl Top Finger Buttons. Silver Plated Mouthpiece. High and Low Pitch.



MELLOPHONE OR CONCERT HORN

In Key of F, with Crooks, for E_b, D and C. High and Low Pitch.

Most bands and orchestras find great trouble in getting a player to master the difficult French horn. In the Mellophone is offered an instrument of the same rich, clear, mellow tone as the French horn, and a perfect substitute for it. The fingering is exactly the same as the Alto and by using the E_b crook the regular Alto parts are played without transposition. It is played in C with piano or organ the same as a Ballad horn or the French horn parts in orchestra or band in F or D.

Every Couesnon Concert Horn has pearl inlaid finger buttons, and finger hook and is furnished with silver plated mouthpiece, music lyre and extra low pitch sleeves.

No.	Each
R354 —Best quality brass, highly polished.....	\$30.00
R354N—Same, nickel plated	34.50
R354B—Same, triple silver plated, rich satin finish, inside of bell highly burnished.....	40.00
R354C—Same, triple silver plated, highly burnished throughout.....	42.50

Burnished gold plating inside of bell, \$5.00 extra

Green Felt Bag to fit, \$1.00

Sole Leather End-opening Case, \$9.50

Fine Plush-lined Side-opening Seal Grain Leather Case, \$12.50

Couesnon & Cie. were recently awarded a contract to supply the French army with 3672 instruments.
Write for special offer and terms on complete sets.

COUESNON & CIE. 20th CENTURY BAND INSTRUMENTS

IMMEASURABLY SUPERIOR TO ALL OTHERS AT SIMILAR PRICES

New Graceful Models. Easy Blowing. Accurate Scale. Light Free Action. Excellent Tone. Pearl Top Finger Buttons. Silver Plated Mouthpiece. High and Low Pitch.

B \flat TENOR SLIDE TROMBONE

HIGH AND LOW PITCH

A very easy blowing instrument with smoothly working slides and of excellent tone quality. Furnished with silver plated mouthpiece, music lyre and extra sleeves for low pitch; 7½-inch bell.

No.	Each
R362 —Best quality brass, highly polished.....	\$20.00
R362N—Same, nickel plated	23.00
R362B—Same, triple silver plated, rich satin finish, inside of bell highly burnished	27.50
R362C—Same, triple silver plated, highly burnished throughout.....	30.00
Burnished gold plating inside of bell, \$4.00 extra.	
Green Felt Bag to fit, \$1.35 Sole Leather End-opening Case, \$8.50	
Plush-lined Side-opening Case, \$12.00	

E \flat ALTO VALVE TROMBONE

HIGH AND LOW PITCH

Equipped with pearl top finger buttons, silver plated mouthpiece, music lyre and extra low pitch sleeves.

No.	Each
R356 —Best quality brass, highly polished.....	\$22.50
R356N—Same, nickel plated	26.00
R356B—Same, triple silver plated, rich satin finish, inside of bell highly burnished	31.00
R356C—Same, triple silver plated, highly burnished throughout.....	33.50
Burnished gold plating inside of bell, \$4.00 extra	
Sole Leather End-opening Case, \$9.00	

B \flat TENOR VALVE TROMBONE

HIGH AND LOW PITCH

Furnished with pearl top finger buttons, silver plated mouthpiece, music lyre and extra low pitch sleeves.

No.	Each
R366 —Best quality brass, highly polished.....	\$27.50
R366N—Same, nickel plated	32.50
R366B—Same, triple silver plated, rich satin finish, inside of bell highly burnished	38.50
R366C—Same, triple silver plated, highly burnished throughout.....	41.50
Burnished gold plating inside of bell, \$4.00 extra	

Green Felt Bag to fit, \$1.25 Sole Leather End-opening Case, \$9.00
Plush-lined Side-opening Seal Grain Leather Case, \$12.50

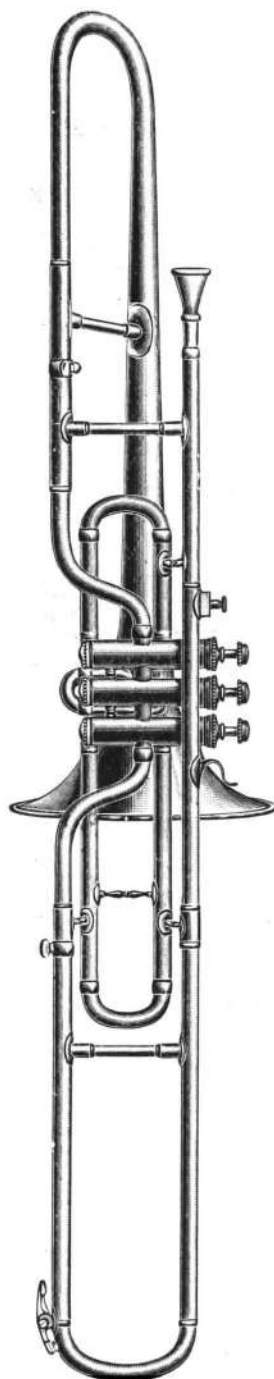

Nos. R366—R366C
Tenor Valve Trombones

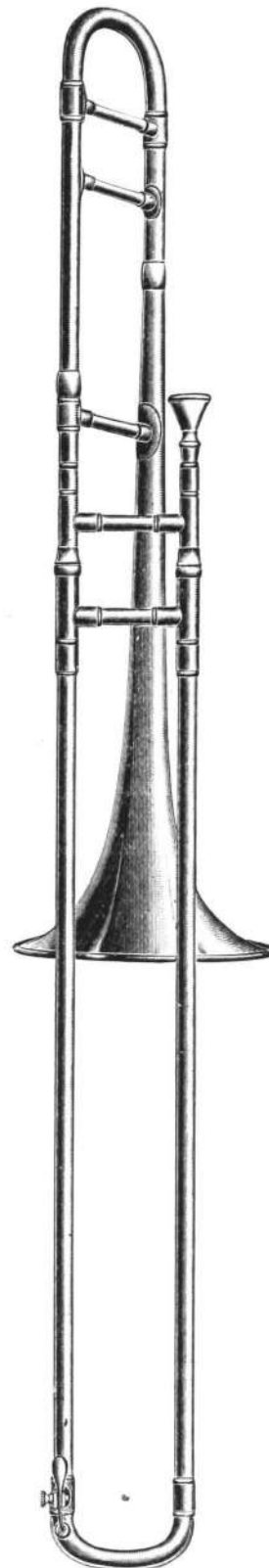

Nos. R362—R362C
Tenor Slide Trombones

Couesnon Band Instruments have been adopted by the French Government for its army and navy musicians. They are used by all the soloists of the famous "Garde Republicaine" Band.

COUESNON & CIE. 20th CENTURY BAND INSTRUMENTS

IMMEASURABLY SUPERIOR TO ALL OTHERS AT SIMILAR PRICES

New Graceful Models. Easy Blowing. Accurate Scale. Light, Free Action. Excellent Tone. Pearl Top Finger Buttons. Silver-plated Mouthpiece. High and Low Pitch

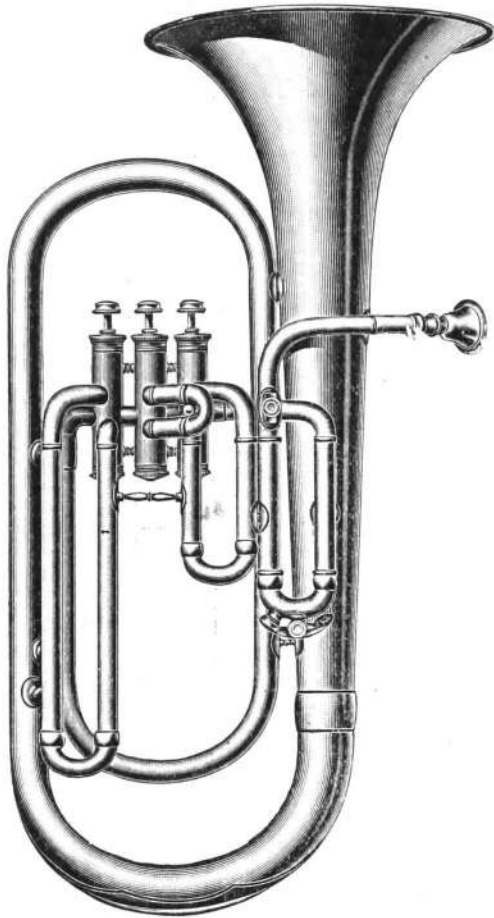

Bb TENOR

HIGH AND LOW PITCH

Furnished with pearl top finger buttons, silver-plated mouthpiece, music lyre and extra Low Pitch sleeves.

No.	Each
R360 —Best quality brass, highly polished.....	\$27.50
R360N—Same, nickel plated	32.00
R360B—Same, triple silver plated, rich satin finish, inside of bell highly burnished	37.50
R360C—Same, triple silver plated, highly burnished throughout.....	40.00

Burnished gold plating inside of bell, \$5.00 extra

Green Felt Bag to fit, \$1.10 Sole Leather End-opening Case, \$9.50

Bb BARITONE

HIGH AND LOW PITCH

Furnished with pearl top finger buttons, silver-plated mouthpiece, music lyre and extra Low Pitch sleeves.

No.	Each
R370 —Best quality brass, highly polished.....	\$32.50
R370N—Same, nickel plated	37.50
R370B—Same, triple silver plated, rich satin finish, inside of bell highly burnished	45.00
R370C—Same, triple silver plated, highly burnished throughout.....	49.00

Burnished gold plating inside of bell, \$5.00 extra

Green Felt Bag to fit, \$1.25 Sole Leather End-opening Case, \$11.00
Fine Plush-lined Side-opening Case, \$15.00



COUESNON & CIE. 20th CENTURY BAND INSTRUMENTS

IMMEASURABLY SUPERIOR TO ALL OTHERS AT SIMILAR PRICES

New Graceful Models. Easy Blowing. Accurate Scale. Light, Free Action. Excellent Tone. Pearl Top Finger Buttons. Silver-plated Mouthpiece. High and Low Pitch

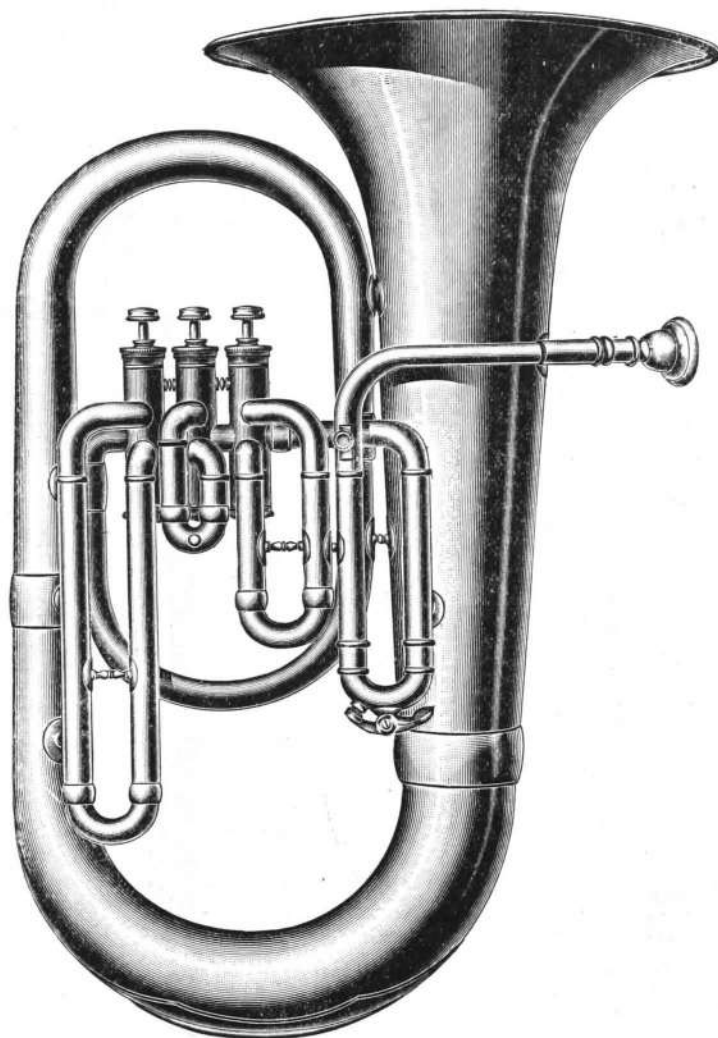

B \flat BASS

HIGH AND LOW PITCH

Furnished with pearl top finger buttons, silver-plated mouthpiece, music rack and extra sleeves for Low Pitch.

No.	Each
R380 —Best quality brass, highly polished.....	\$36.00
R380N —Same, nickel plated	42.00
R380B —Same, triple silver plated, rich satin finish, inside of bell highly burnished.....	53.50
R380C —Same, triple silver plated, highly burnished throughout.....	58.50

Burnished gold plating inside of bell, \$6.00 extra

Green Felt Bag to fit, \$1.40

End-opening Sole Leather Case, \$12.00

Couesnon & Cie. are the largest band instrument manufacturers in the world. Their factories at Paris, Chateau-Thierry and Garennes employ almost a thousand workmen.

COUESNON & CIE. 20th CENTURY BAND INSTRUMENTS

IMMEASURABLY SUPERIOR TO ALL OTHERS AT SIMILAR PRICES

New Graceful Models. Easy Blowing. Accurate Scale. Light, Free Action. Excellent Tone. Pearl Top Finger Buttons. Silver-plated Mouthpiece. High and Low Pitch

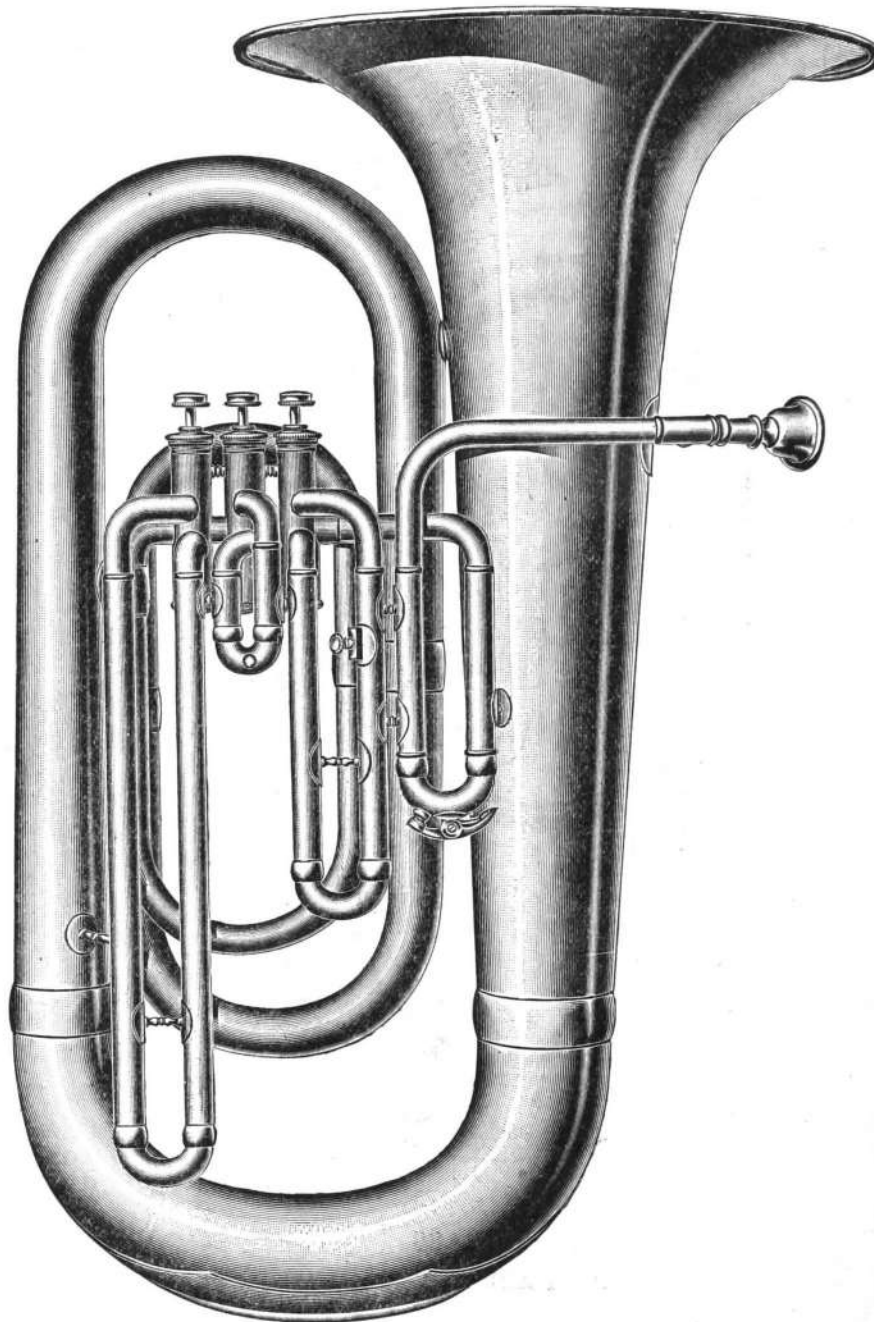

E^b BASS

HIGH AND LOW PITCH

Each instrument furnished with pearl top finger buttons, silver-plated mouthpiece, music lyre and extra sleeves for Low Pitch.

No.	Each
R390 —Best quality brass, highly polished.....	\$45.00
R390N—Same, nickel plated	52.50
R390B—Same, triple silver plated, rich satin finish, inside of bell highly burnished	65.00
R390C—Same, triple silver plated, highly burnished throughout.....	71.00

Burnished gold plating inside of bell, \$8.00 extra

Green Felt Bag to fit, \$1.50

Sole Leather End-opening Case, \$17.50

We sell on Easy Monthly Installments. Ten days trial allowed. Liberal allowances for second-hand instruments in exchange.

COUESNON & CIE., PARIS, "AMERICAN PERFECTION" LIGHT ACTION BAND INSTRUMENTS

MADE ESPECIALLY FOR US AND COPIED AFTER THE VERY BEST MODELS OF THE LEADING AMERICAN MANUFACTURERS

"American Perfection" Instruments represent the very highest grade of imported band instruments. They offer the perfection of the finest American made Horns at very little more than the prices asked for ordinary grades of imported band instruments. In beauty of model, accuracy and durability of construction, ease of blowing, quality and volume of tone, correctness of intonation, they are surpassed by only the very finest American makes—instruments which are sold at double the price or more.

"American Perfection" Instruments are the most up-to-date American designs, and embody the latest ideas and discoveries of the leading American manufacturers. The Cornets are three of the most popular models on the American market; the Trombone is identical with one of the recognized standard instruments, while the larger instruments are copies, down to the smallest details, of the most highly regarded American makes.

GENERAL SPECIFICATIONS

Tempered brass of the finest grade is employed, the metal being drawn out, spun and welded in the most workmanlike manner.

The pistons are of German silver, accurately made and individually ground into their casings. All joints, braces, rings and trimmings are neatly finished and brazed with great care. All slides are ground and fitted with precision, working easily and smoothly. Finger buttons inlaid with pearl. Extra slide with each instrument for Low Pitch. Bells ornamented with beautiful engraved floral wreath.



View of a portion of the interior of Couesnon & Cie.'s Paris factory

COUESNON & CIE., PARIS, "AMERICAN PERFECTION" LIGHT ACTION BAND INSTRUMENTS

Handsome Appearance. Well Balanced. Durable Construction. Light, Responsive Action. Perfect Intonation. Easier Blowing than most Instruments at twice their price. Copied from leading makes.

COUESNON & CIE. AMERICAN PERFECTION BESSON TYPE CORNET

No. R819
In B \flat and A High and Low Pitch

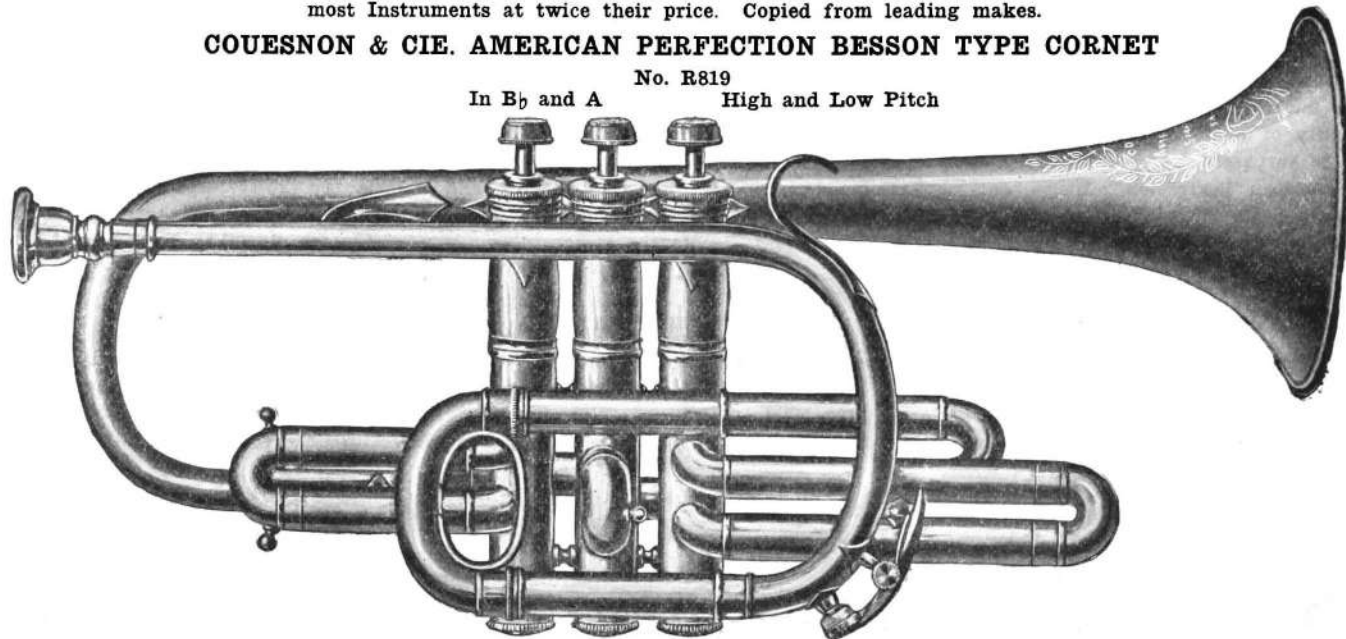

This Cornet is a replica of the most popular model ever put out by the great English manufacturers and embodies one of the simplest and most effective quick change to A attachments ever devised. This is invisible but perfect in its operation, the change to A being made by simply drawing the tuning slide—no levers or rods to strain, stick or rattle. The bore is medium large and the instrument is an exceptionally free-blowing one. The Cornet is furnished with pearl top finger buttons, incased springs, extra slide for Low Pitch, silver-plated mouthpiece and music lyre. Handsomely engraved wreath on bell. A high-grade instrument in every respect.

No.	Each
R819 —Finest quality brass, highly polished.....	\$25.00
R819B—Same, silver plated, rich satin finish, inside of bell, tops and bottoms of valves and water key highly burnished.....	33.00
R819D—Same as R819B but with inside of bell gold plated and highly burnished	36.00

COUESNON & CIE., AMERICAN PERFECTION "LATEST INVENTION" CORNET

No. R821
In B \flat and A High and Low Pitch

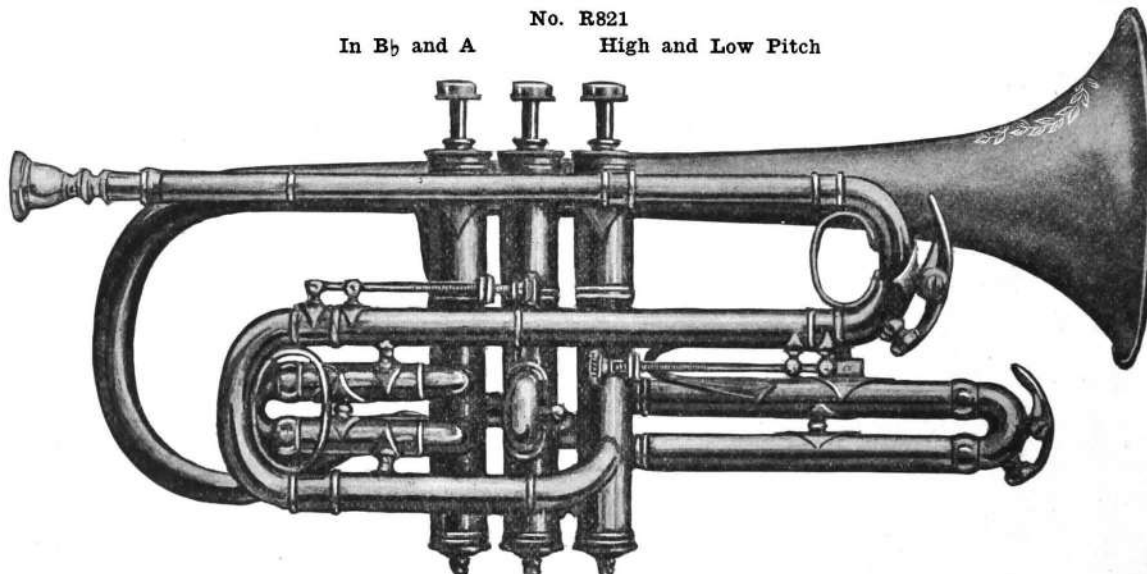

This "Latest Invention," Long Model Cornet is up to date in every respect and has all the refinements in workmanship found in the most expensive American-made instruments. It has pearl top key buttons, box spring valves, rod and button automatic stops on both Low Pitch and Quick Change to A slides, two water keys; handsomely engraved wreath on bell.

No.	Each
R821 —Finest quality brass, highly polished.....	\$25.00
R821B—Same, silver plated, rich satin finish, inside of bell, tops and bottoms of valves and water keys highly burnished.....	33.00
R821D—Same as No. R821B, but with inside of bell gold plated and highly burnished.....	36.00

See page 6 for shipping weights.

COUESNON & CIE., PARIS, "AMERICAN PERFECTION" LIGHT ACTION BAND INSTRUMENTS

Handsome Appearance. Well Balanced. Durable Construction. Light, Responsive Action. Perfect Intonation. Easier Blowing than most instruments at twice their price. Copied from leading American makes

COUESNON & CIE. AMERICAN PERFECTION "PROFESSIONAL" MODEL CORNET

No. R825

In B_b and A High and Low Pitch

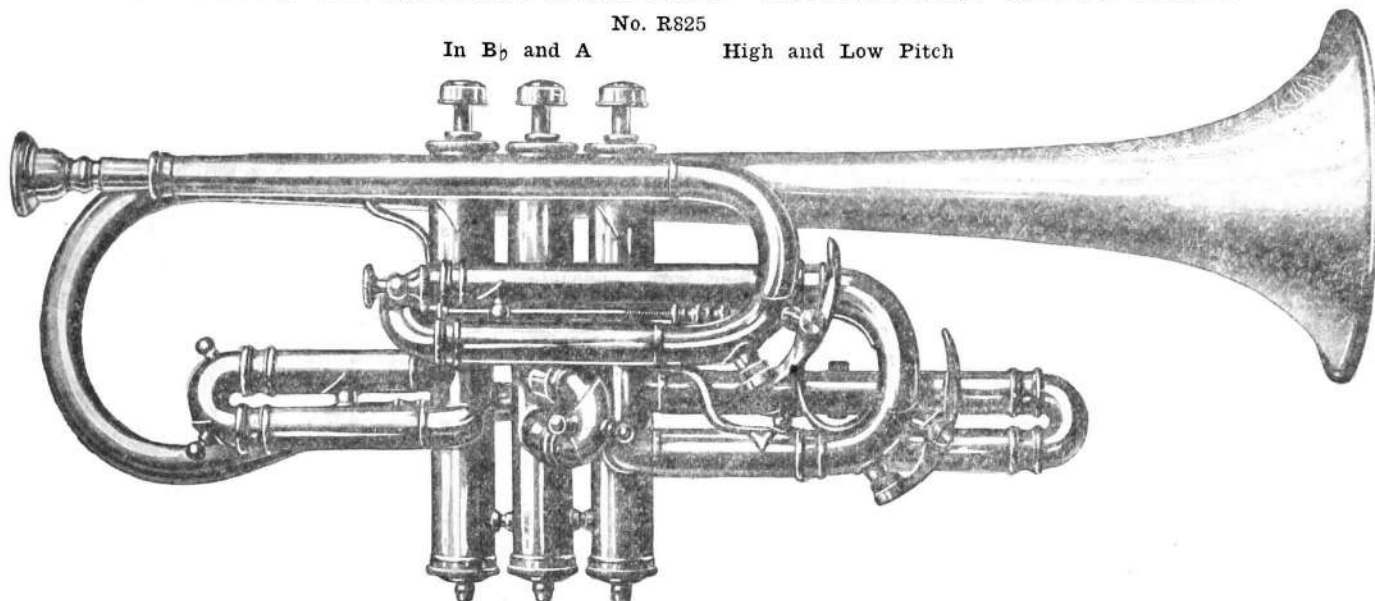

Here is a beautiful and symmetrical model of thoroughly practical design that combines the brilliance of the trumpet with the smooth compactness of the cornet tone, and is consequently an instrument that meets all requirements for band and orchestra work. It is copied after a very popular American model, one which has been used with success by soloists for several years past. Note the graceful bending of the mouthpipe and the perfectly modeled bell. The slide for quick change from B_b to A is conveniently located where it can be operated without taking the hands from their regular position on the instrument. The High and Low Pitch slide, located below and beyond the quick change to A slide, is just where it should be for both appearance and utility. Excellent workmanship throughout. Box spring valves ground in so that they are practically air tight, insuring a light action and an easy blowing instrument. Extra Low Pitch slide. Pearl top finger buttons, silver-plated mouthpiece. Handsomely engraved wreath on bell.

No.	Each
R825 —Finest quality brass, highly polished.....	\$27.50
R825B—Same, silver plated, rich satin finish, inside of bell, tops and bottoms of valves and water keys highly burnished.....	35.50
R825D—Same as No. R825B, but with inside of bell gold plated and highly burnished.....	38.50

COUESNON & CIE. AMERICAN PERFECTION PROFESSIONAL TRUMPET

No. R829

In B_b and A High and Low Pitch

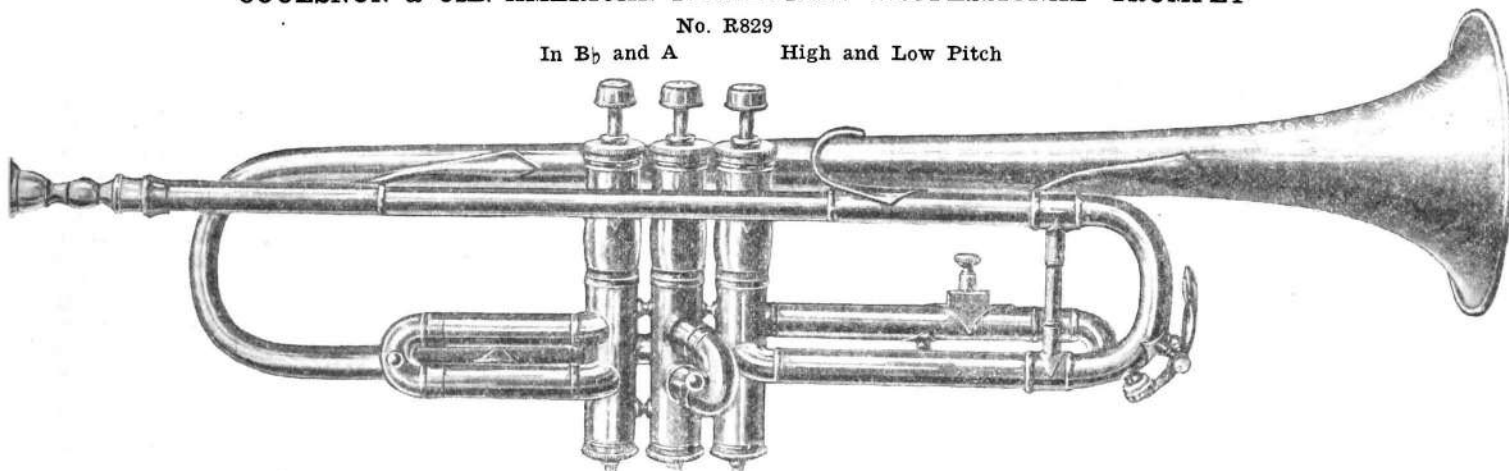

This is a real Trumpet of perfect proportions and proper trumpet bore, not a cornet built in trumpet shape. The length is 19 inches. Of brilliant and even tone throughout its register, it affords the musician a thoroughly practical, efficient instrument at one-half the price of the best American makes. It is provided with "a slide within a slide" whereby you can tune to any pitch and still use the quick change to A slide. There is a rod attachment for pulling to A (not shown in the illustration), while the end of the slide pulls out to Low Pitch. An extra Low Pitch slide is also furnished for those who would rather insert a longer slide than pull the one in the instrument. The Trumpet is equipped with pearl top finger buttons and silver-plated mouthpiece and music lyre are included. Engraved wreath on bell.

No.	Each
R829 —Finest quality brass, highly polished.....	\$27.50
R829B—Same, silver plated, rich satin finish, inside of bell, tops and bottoms of valves and water keys highly burnished.....	35.50
R829D—Same as No. R829B, but with inside of bell gold plated and highly burnished.....	38.50

COUESNON & CIE., PARIS, "AMERICAN PERFECTION" LIGHT ACTION BAND INSTRUMENTS

Handsome Appearance. Well Balanced. Durable Construction. Light, Responsive Action. Perfect Intonation. Easier Blowing than most instruments at twice their price. Copied from leading American makes

COUESNON & CIE. AMERICAN PERFECTION E^b ALTO

No. R835

HIGH AND LOW PITCH

A Horn of surprising quality for the price. Accurately in tune, with a splendid action and a tone of most pleasing, mellow, yet penetrating quality—clear and powerful in all registers. Furnished with an extra slide for Low Pitch, pearl top finger buttons, silver-plated mouthpiece and music lyre, Handsomely engraved wreath on bell. Bell diameter, 9 inches.

No.	Each
R835 —Finest quality brass highly polished.....	\$30.00
R835B—Same, silver plated, rich satin finish, inside of bell and all points highly burnished	41.00
R835D—Same as No. R835B, but with inside of bell gold plated and highly burnished	45.00
Green Felt Bag to fit, \$1.00	
Sole Leather End-opening Case, \$9.00	
Fine Plush-lined Side-opening Case, \$12.50	

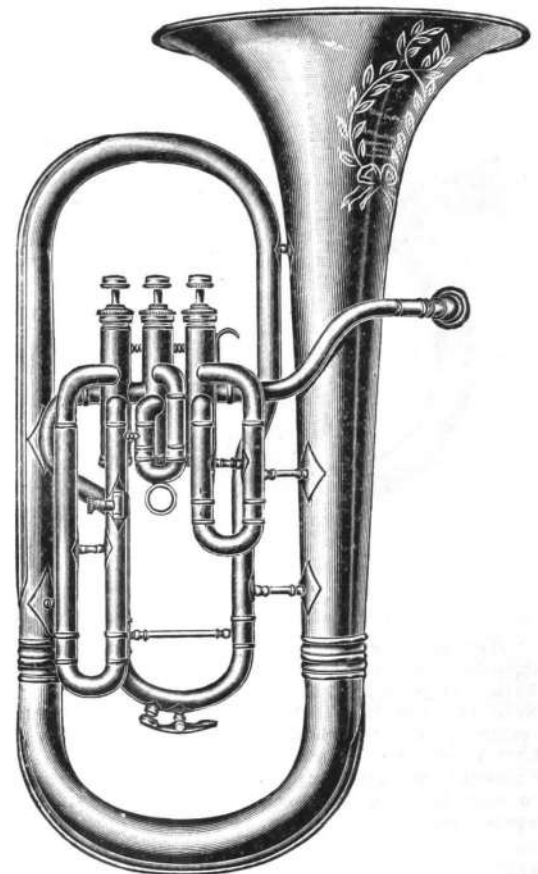

COUESNON & CIE. AMERICAN PERFECTION CONCERT HORN OR MELLOPHONE

No. R837

HIGH AND LOW PITCH

In the key of F, with crooks for E^b, D and C. High and Low Pitch. During the last three or four years the Concert Horn, Mellophone or Circular Alto, as it is variously called, has attained tremendous popularity. The American Perfection Concert Horn, which is copied exactly from the recognized leader among American makes, has a tone of a rich, mellow quality, closely approaching that of the French Horn, while it presents none of the technical difficulties of that instrument, being fingered the same as the Alto and played quite as easily. The crooks with which it is supplied enable the performer to play from French Horn parts in F or D, from Alto parts in E^b, and from piano music in C, all without transposition. Handsomely engraved wreath on bell, pearl top finger buttons, silver-plated mouthpiece, music lyre.

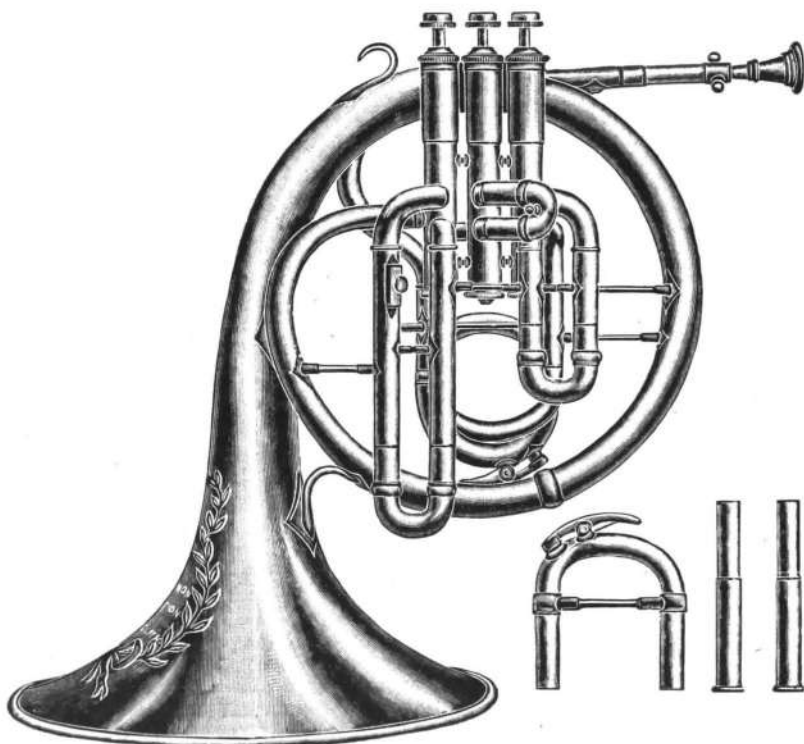

No.	Each
R837 —Finest quality brass, highly polished....	\$37.50
R837B—Same, silver plated, rich satin finish, inside of bell and all points highly burnished	50.00
R837D—Same as No. R837B, but with inside of bell gold plated and highly burnished.	55.00
Green Felt Bag to fit, \$1.00	
Sole Leather End-opening Case, \$9.50	
Fine Plush-lined Side-opening Case, \$12.50	

Second-hand Instruments taken in part payment. If you have one to offer, send for blank on which to describe it—our allowances are liberal. Easy monthly installments accepted.

COUESNON & CIE., PARIS, "AMERICAN PERFECTION" LIGHT ACTION BAND INSTRUMENTS

Handsome Appearance. Well Balanced. Durable Construction. Light, Responsive Action. Perfect Intonation. Easier Blowing than most instruments at twice their price. Copied from leading American makes



COUESNON & CIE., AMERICAN PERFECTION "EMPEROR" MODEL SLIDE TROMBONE

No. R845

HIGH AND LOW PITCH

Medium bore; bell diameter, 7 inches; weight 42 ounces; width of slide, 2¾ inches, inside measurement.

A high-grade Trombone at about half the price asked for American standard makes, of one of the most popular of which the "Emperor" is an exact reproduction. It is beautifully proportioned, the bore, bell, weight and measurements being just right. The balance is perfect, the instrument lying in the hands at just the correct angle for the greatest ease of manipulation. Very easy blowing and with a fine quality of tone of remarkable carrying power. Long German silver stockings, perfectly fitted, insure a light, easy slide action. An extra slide for Low Pitch, silver mouthpiece and music rack are included. Bell handsomely engraved.

No.	Each
R845 —Finest quality brass, highly polished.....	\$25.00
R845B—Same, silver plated, rich satin finish, inside of bell and all points highly burnished	35.00
R845D—Same as No. R845B, but inside of bell gold plated and highly burnished	39.00

Green Felt Bag to fit, \$1.35 End-opening Sole Leather Case, \$8.50
Fine Plush-lined Side-opening Case, \$12.00

COUESNON & CIE., AMERICAN PERFECTION TENOR VALVE TROMBONE

No. R849

HIGH AND LOW PITCH

A perfectly balanced Long Model Instrument which offers a splendid substitute for the Slide Trombone to those who find it difficult to locate the positions on that instrument. The tone is large, of excellent compass, and while it has not the snappiness of the slide, it is of the true trombone quality. Light, responsive valve action. German silver pistons with pearl inlaid finger buttons. The bell is handsomely engraved with a wreath. An extra slide for Low Pitch, silver-plated mouthpiece and music rack are included. Diameter of bell, 7 inches.

No.	Each
R849 —Finest quality brass, highly polished.....	\$32.50
R849B—Same, silver plated, rich satin finish, inside of bell and all points highly burnished	46.50
R849D—Same as No. R849B, but inside of bell gold plated and highly burnished	50.50

Green Felt Bag to fit, \$1.25 End-opening Sole Leather Case, \$9.00
Fine Plush-lined Side-opening Case, \$12.50

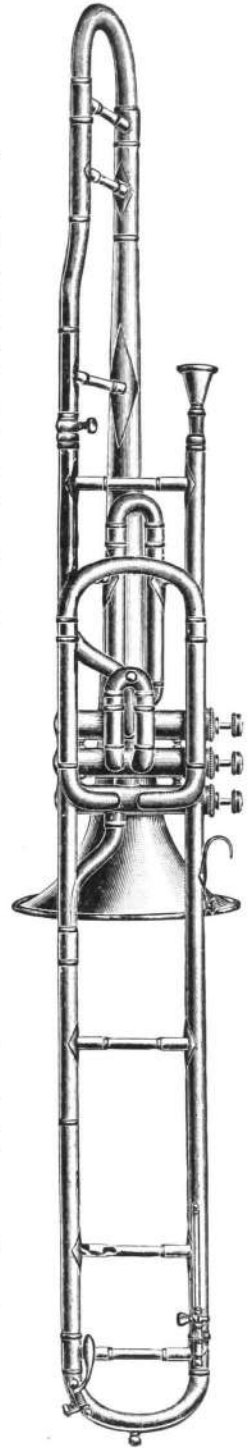

COUESNON & CIE., PARIS, "AMERICAN PERFECTION" LIGHT ACTION BAND INSTRUMENTS

Handsome Appearance. Well Balanced. Durable Construction. Light, Responsive Action. Perfect Intonation. Easier Blowing than most instruments at twice their price. Copied from leading American makes

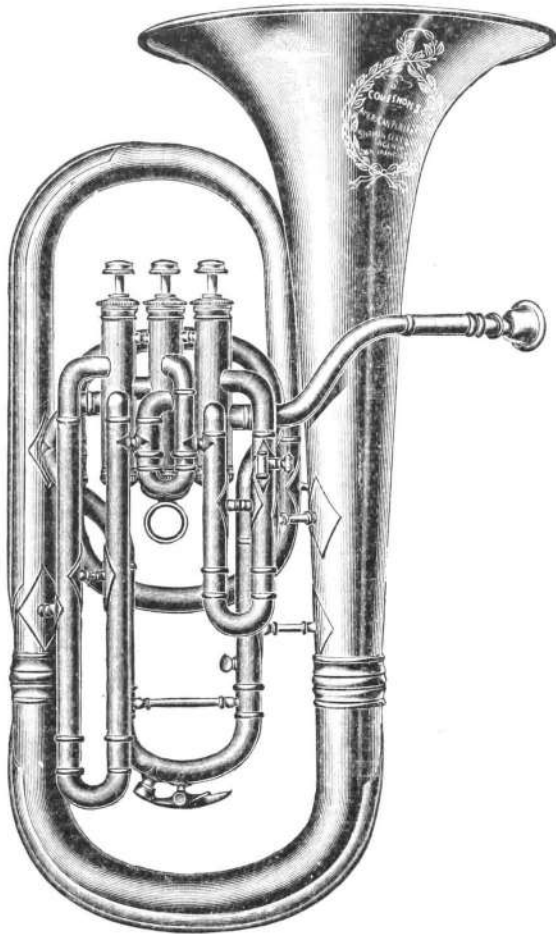

COUESNON & CIE., AMERICAN PERFECTION B \flat TENOR

No. R841

HIGH AND LOW PITCH

A Tenor of liberal bore, producing a large round tone of true tenor quality. Free blowing throughout its entire register and accurately in tune. Furnished with an extra slide for Low Pitch, pearl top finger buttons, silver-plated mouthpiece and music lyre. Handsomely engraved wreath on bell. Bell diameter, 10 inches.

No.	Each
R841 —Finest quality brass, highly polished.....	\$32.50
R841B—Same, silver plated, rich satin finish, inside of bell and all points highly burnished	45.00
R841D—Same as No. R841B, but inside of bell gold plated and highly burnished	50.00

Green Felt Bag to fit, \$1.10 Sole Leather End-opening Case, \$9.50

Medals awarded at
Expositions to
Couesnon, Gautrot & Cie.,
successors to
Gautrot, Aine & Cie.

Couesnon, Gautrot & Cie.
were in 1882 succeeded
by the present firm—
Couesnon & Cie.
See Historical Sketch
on page 60.

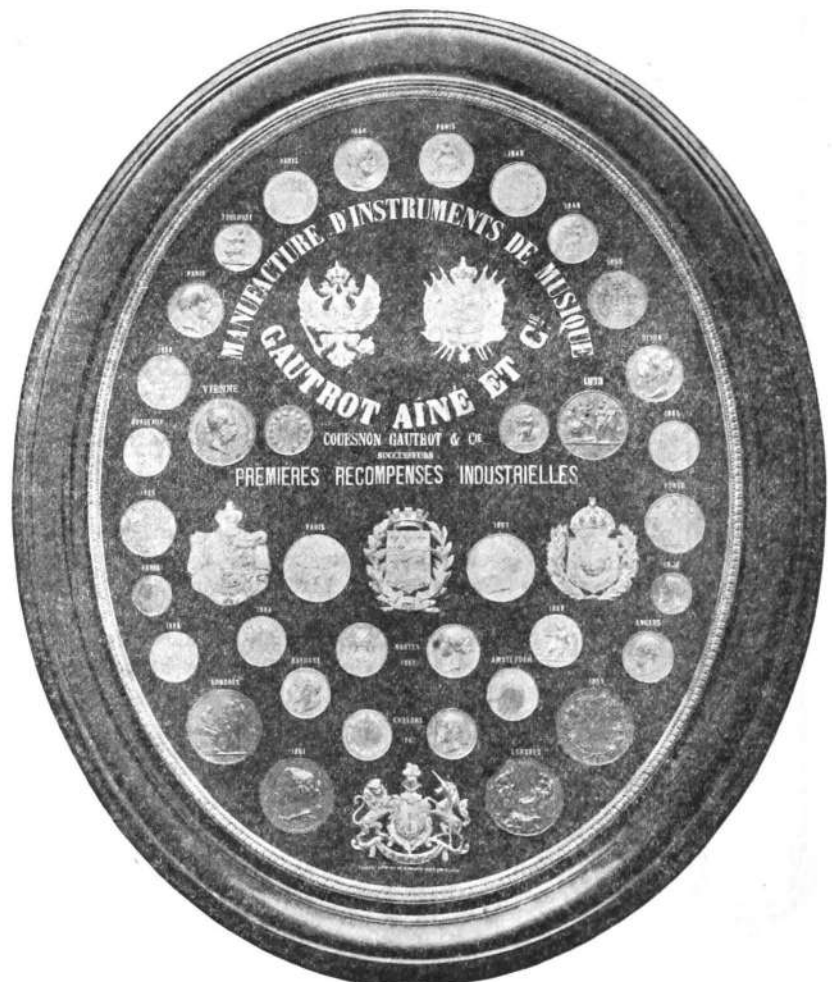

Couesnon Band Instruments are the choice of the French Government for their army and navy musicians. They are used by all the soloists of the most famous band in the world, the "Garde Republicaine."

COUESNON & CIE., PARIS, "AMERICAN PERFECTION" LIGHT ACTION BAND INSTRUMENTS

Handsome Appearance. Well Balanced. Durable Construction. Light, Responsive Action. Perfect Intonation. Easier Blowing than most instruments at twice their price. Copied from leading American makes.

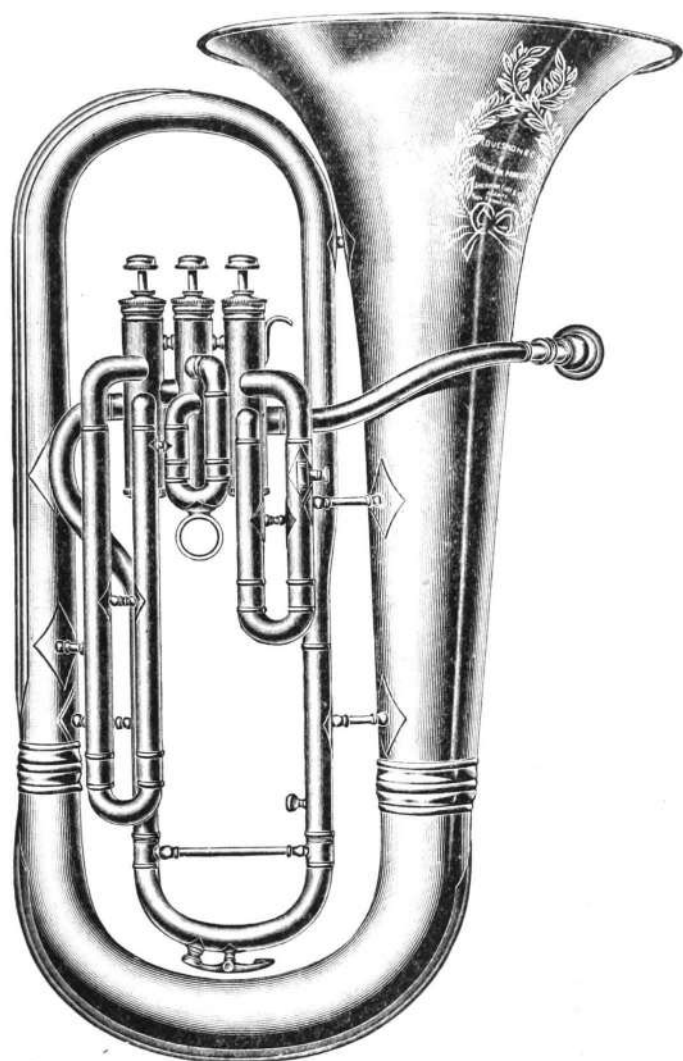

COUESNON & CIE., AMERICAN PERFECTION B₇ BARITONE

No. R855

HIGH AND LOW PITCH

A splendid, compactly built Baritone, patterned after a recognized leader in American high-grade instruments. The bore is large, resulting in a free blowing instrument of fine tone quality. The workmanship throughout is up to the high standard of all the other American Perfection instruments, the action light and responsive, the scale perfectly in tune. An extra slide is provided for Low Pitch, silver mouthpiece and music rack are included. Bell handsomely engraved. Pearl inlaid finger buttons.

No.	Each
R855 —Finest quality brass, highly polished.....	\$40.00
R855B—Same, silver plated, rich satin finish, inside of bell and all points highly burnished	56.50
R855D—Same as No. R855B, but with inside of bell gold plated and highly burnished.....	61.50

Green Felt Bag to fit, \$1.25 Sole Leather End-opening Case, \$11.00
Fine Plush-lined Side-opening Case, \$15.00

Dimensions: 25 inches high, 14¹/₄ inches in width. Diameter of bell, 11 inches.



COUESNON & CIE., AMERICAN PERFECTION LONG MODEL BARITONE OR EUPHONIUM

No. R857

HIGH AND LOW PITCH

In this American Perfection Long Model Baritone we offer an instrument of large bore with exceptional power, capable of fulfilling the heaviest requirements made upon a Baritone. The tone is produced with a minimum of lung power and lip tension and the perfection of the scale is a feature of the instrument, as it is of all American Perfections. The model is one which has been popular for many years with Baritone and Euphonium players the world over, the design being a very graceful one. It is furnished with pearl top finger buttons, extra slide for Low Pitch, silver-plated mouthpiece and music lyre. Bell handsomely engraved.

No.	Each
R857 —Finest quality brass, highly polished.....	\$40.00
R857B—Same, silver plated, rich satin finish, inside of bell and all points highly burnished.....	56.50
R857D—Same as No. R857B, but inside of bell gold-plated and highly burnished	61.50

Write for special offer on complete sets. Ten days trial allowed on all band instruments. If not satisfactory they are returnable at our expense.

COUESNON & CIE., PARIS, "AMERICAN PERFECTION" LIGHT ACTION BAND INSTRUMENTS

Handsome Appearance. Well Balanced. Durable Construction. Light, Responsive Action. Perfect Intonation. Easier Blowing than most instruments at twice the price. Copied from leading American makes.

COUESNON & CIE. AMERICAN PERFECTION E^b BASS
No. R861

Diameter of bell, 16 inches; width, 16 inches; height, 29½ inches



This is a medium sized Bass built, as the illustration shows, on most elegant lines, and its playing qualities are in keeping with its appearance. The action is light, short and responsive, the instrument blows freely and in perfect tune, while the tone is beautiful and powerful. An extra slide for Low Pitch, silver-plated mouthpiece and music rack are included. Pearl top finger buttons. Bell handsomely engraved.

No.	Each
R861 —Finest quality brass, highly polished.....	\$55.00
R861B—Same, silver plated, rich satin finish, inside of bell and all points highly burnished	81.00
R861D—Same as No. R861B, but inside of bell gold plated and highly burnished	89.00

Green Felt Bag to fit, \$2.00. Sole Leather End-opening Case, \$22.50

Second-hand instruments taken in part payment. If you have one to offer, send for blank on which to describe it—our allowances are liberal. Easy monthly installments accepted.

COUESNON & CIE., PARIS, "AMERICAN PERFECTION" LIGHT ACTION BAND INSTRUMENTS

Handsome Appearance. Well Balanced. Durable Construction. Light, Responsive Action. Perfect Intonation. Easier Blowing than most instruments at twice their price. Copied from leading American makes.

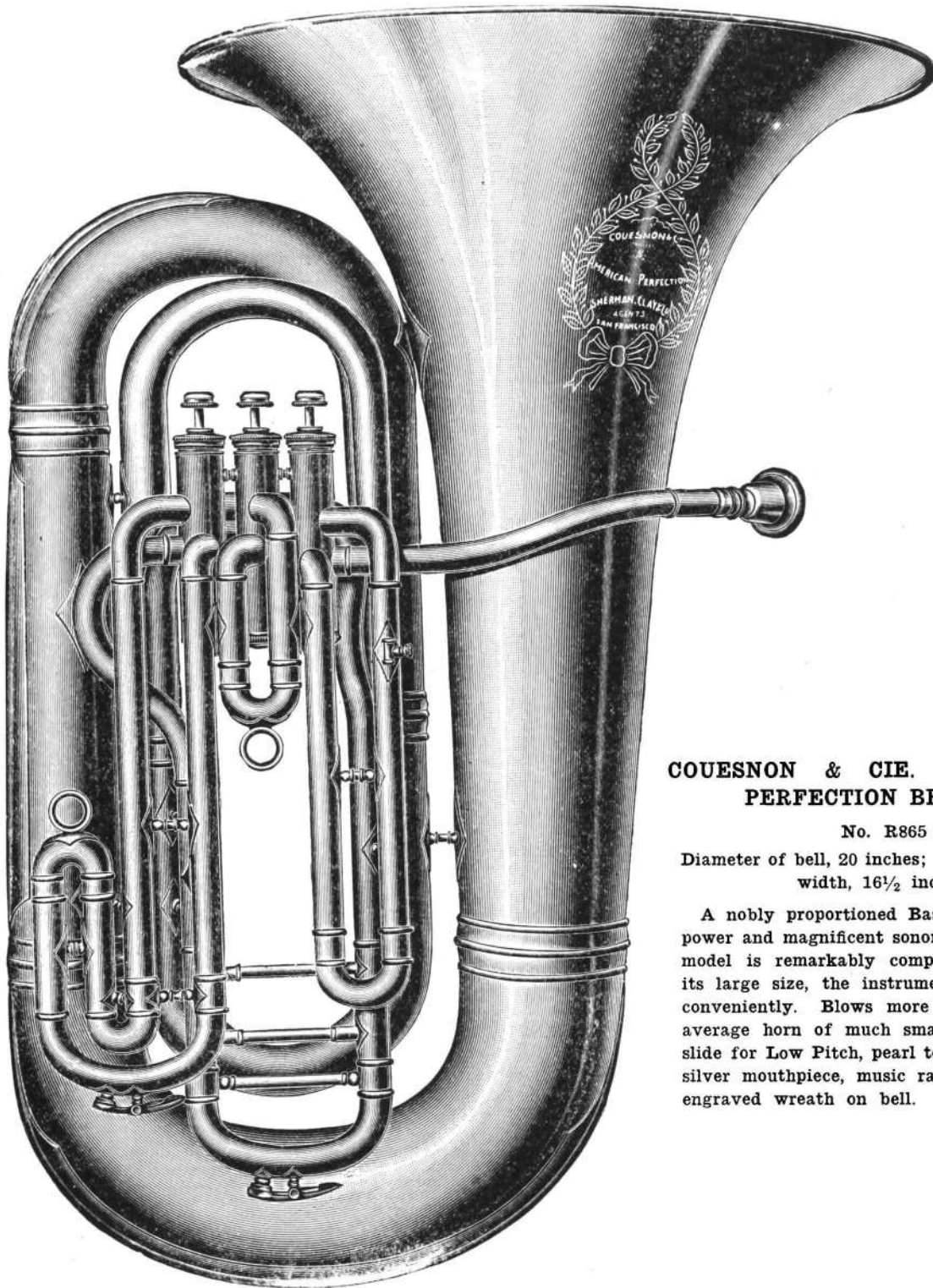

COUESNON & CIE. AMERICAN PERFECTION BB^b BASS

No. R865

Diameter of bell, 20 inches; height 34 inches; width, 16½ inches.

A nobly proportioned Bass of tremendous power and magnificent sonority of tone. The model is remarkably compact, and despite its large size, the instrument handles most conveniently. Blows more easily than the average horn of much smaller size. Extra slide for Low Pitch, pearl top finger buttons, silver mouthpiece, music rack. Handsomely engraved wreath on bell.

No.	Each
R865 —Finest quality brass, highly polished.....	\$ 80.00
R865B —Same, silver plated, rich satin finish, inside of bell and all points highly burnished.....	112.50
R865D —Same as No. R865B but inside of bell gold plated and highly burnished	125.00
Sole Leather End-opening Case, \$27.50	

Couesnon instruments sent anywhere on 10 days' trial—to be returned at our expense if not found satisfactory

C. F. SCHMIDT, BERLIN, GERMANY, CELEBRATED FRENCH HORNS, SINGLE AND DOUBLE

WITH FINEST AMERICAN STYLE ROTARY VALVES, SPRING ACTION.

BUILT IN LOW PITCH

The following are the names of some of the artists who use the celebrated Schmidt Horns, and to whom we respectfully refer

NEW YORK AND BROOKLYN

H. DUTSCHKE	J. DOUGHERTY	R. LOESIT
R. LETSH	PH. LOTZE	F. LA CROIX
FRANK PRELLER	R. LEHMANN	FRANK KLEIN
F. VOSS	W. RINGER	B. BAUMGAERTEL
J. BLODGETT	O. GEBHARDT	J. WEBER
R. HAND	R. LANGE	H. WESTON
H. NEUBAUER	W. RITTMER	R. RIESE

CHICAGO

E. BRAUN	A. SAALBACH	R. IVERSON
A. MUELLER	H. JOHNSCHER	A. CARANCI
L. CHAPEK	C. BERGER	

PHILADELPHIA

J. KOCH	JOS. DREW	A. ZOELLNER
---------	-----------	-------------

BOSTON

F. HEIN	G. HEIM	G. W. BUCK
	A. HACKEBARTH	

SAN FRANCISCO

W. DABELOW	F. HUSKE	C. WITTHOFF
	A. G. AYLESWORTH	R. ROCCO

MINNEAPOLIS

FRANK LAROSE	M. MATTHIEU
--------------	-------------

MISCELLANEOUS

J. DAILY, Providence	C. BERNARD, Cincinnati
HENRY GLUCK, Rochester	B. KOLLBERG, Altoona
H. HAND, Buffalo	FR. FISCHER, Cleveland
P. HOLLEY, Annapolis	E. SMITH, Los Angeles
JOS. FRANZEL, Pittsburgh	P. SCHIRNER, New Haven
E. C. O'NEIL, Bangor, Me.	F. EISENHART, Shamokin, Pa.
J. A. JOHNSON, Hartford, Conn.	L. MALECKI, Chicago, Ill.
L. E. VAN AMBUGH, Detroit, Mich.	
ROBERT OGLESBY, 1st Horn, Wilmington, Del.	
A. R. HART, 2nd Horn, Wilmington, Del.	
Also 3rd and 4th Horn players of same organization	
W. M. KAIN, Musical Enterprise, Camden, N. J.	
C. H. BURNS, Salt Lake City, Utah	

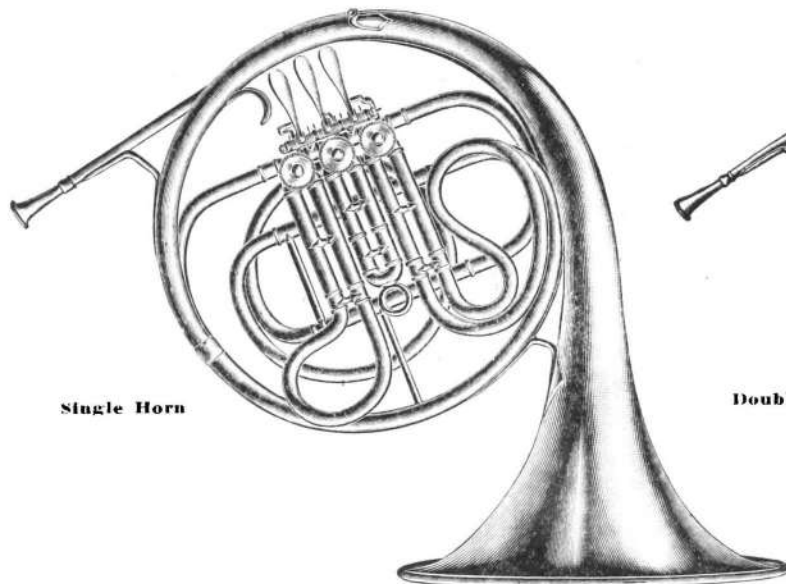

Single Horn



Double Horn

- | | | |
|------|---|----------|
| No. | | Each |
| R970 | Schmidt Single French Horn, in brass, built in F Low Pitch | \$ 90.00 |
| R973 | Schmidt Double French Horn, in brass, in F and B _♭ Low Pitch, with extra B _♭ crook and extra piston valve for change to A | 150.00 |
| | Prices on plated finishes upon application. | |

FRENCH HORN CASE

- | | | |
|------|---|---------|
| No. | | Each |
| R128 | Side opening, velvet lined, to fit either single or double horn | \$15.00 |

OF INTEREST TO HORN PLAYERS

Considering that the greatest possible care be taken in tuning with other instruments, there will always be a difference of opinion as regards exact methods employed for change of pitch of French Horns. One player's embouchure will be more decided and in consequence he will blow sharper, while another will produce his notes with less decision and consequently blow flatter. Such cases are of very frequent occurrence. In view of such conditions it seems proper and advisable to construct an instrument somewhat sharper, so to say, from the very outset, in order that a player may always be in a position to alter or regulate as circumstances may demand.

The invention of the C. F. Schmidt Double-horn in F and B_♭ facilitates the entire manipulation of the French Horn to a remarkable extent. The fundamental, natural and principal pitch of the Double Horn is "F," while through pressure of a special "piston valve" the secondary pitch of B_♭ is obtained. Through the unique construction of this instrument a player even with weakened embouchure is enabled to produce the higher register with exceptional ease and with less than half the customary exertion.

Should the player desire to change the fundamental pitch of the horn to that of B_♭ and make F the secondary one, he need only place the special valve, furnished with every instrument, in its proper position. This is done by unscrewing the cap, taking off the finger button and placing the valve in position; after screwing the cap and finger button firmly together as before, a pressure upon the valve will place the instrument in the secondary pitch of "F."

Should the player desire the pitch of "A" the extra crook with revolving valve for low pitch is inserted in place of the single B_♭ crook. If "A" is to be used the indicator is reversed and the piston valve is pressed down, that is to say, if the valve has been inserted making "F" the fundamental pitch.

In drawing out the B_♭ crook containing this indicator or revolving valve for one inch, we obtain the pitch of E. If the instrument is fundamentally placed in B_♭, through insertion of the B_♭ valve, we need only reverse the indicator and the instrument will be pitched in A. Of course, through pressure of the valve we obtain F as secondary pitch, if the indicator (in B_♭) has again been reversed. Otherwise, by drawing out the crook of the A valve we would obtain the pitch of E.

In this way the pitch of the instrument may be conveniently altered to either B_♭, A, F or E. The latter, of course, only if the appropriate crook is drawn out sufficiently. Consequently the player is enabled to make either "F" or "B_♭" the fundamental pitch, through use of the special valve supplied for this purpose.

The player who is the fortunate possessor of a Schmidt French Horn will find that it obviates to the greatest possible extent the many worriments which usually are the bane of every French Horn player; especially as regards over-exertion or tiring of the lip, which is so common. Added to this is the positiveness and ease with which high notes are obtained—another exclusive feature of the famous Schmidt Horns.

All noted professional French Horn players use them, and endorse them in the most enthusiastic manner.

CORNET SACHELS AND CASES



Cornet Satchel No. R72



Cornet Satchel No. R73



Cornet Satchel No. R75, for Regular Model
Cornet Satchel No. R76, for Long Model



No. R3
Shoulder Strap



Cornet Case No. R1



Cornet Case No. R4
Long Model Cornet Case No. R5
Trumpet Case No. R6

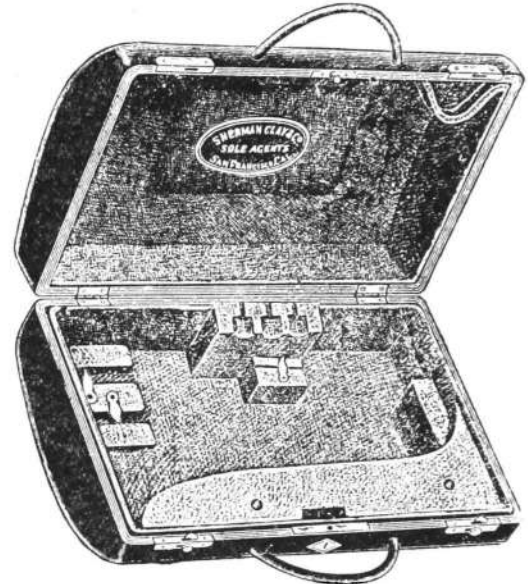

Cornet Case No. R164

No.		Each
R 72	—Imitation leather, flannel lined, inside pocket for attachments, leather handle and shoulder strap.....	\$1.60
R 73	—Black pebbled leather, hand sewed, lined with fleeced flannel, inside pocket for attachments, nickel trimmings, leather handle and shoulder strap.....	2.50
R 75	—Solid sole leather, nicely embossed, black or russet, all hand sewed, fleeced flannel lined, inside pocket, nickel catches and name plate, leather shoulder strap.....	3.50
R 76	—Same as No. R75 but longer; fits all Long Model Cornets.....	4.00
R 1	—Keratol, pebbled leather finish, velvet lined, leather handle, nickel spring fasteners, lock and corner protectors.....	5.50
R 4	—Seal grain leather covered, lined with silk plush, lock, patent fasteners, name plate and corner protectors all heavily nickel plated. Places in bed of case for mouthpieces, music rack, valve cleaner and set of slides. The handsomest, best and most convenient Cornet Case on the market.....	8.00
R 5	—Same as No. R4, but longer, to fit Long Model Cornets.....	8.50
R 6	—Same as No. R4, but much longer, for Trumpets.....	9.50
R164	—Professional Model heavy grained leather covered, lined with finest quality of velvet, patent countersunk sample case catches, all trimmings heavily nickel plated, fine leather handles; a very elegant, durable case.....	9.00

SHOULDER STRAPS

No.		Each
R 3	—Leather, black or russet, for Cornet satchels, music satchels, etc. (Postage, 4 cts.).....	\$0.40

BAND INSTRUMENT BAGS

Green Felt, Unlined

No.	Each	No.	Each
R60—Cornet (postage, 3 cts.).....	\$0.60	R65—B \flat Bass.....	\$1.40
R61—E \flat Alto.....	1.00	R66—E \flat Bass, medium size.....	1.50
R62—Mellophone or Concert Horn.....	1.00	R67—E \flat Bass, monster size.....	2.00
R63—Tenor.....	1.10	R70—Tenor Valve Trombone.....	1.25
R64—Baritone.....	1.25	R71—Slide Trombone.....	1.35

Postage: All of the above Bags take the 1-lb. rate by Parcel Post

BAND INSTRUMENT CASES—END OPENING



Nos. R20 and R20½, R21 and R21½



No. R24

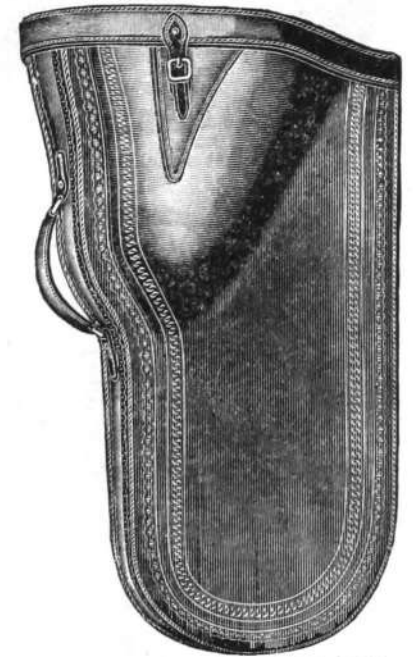

Nos. R25, R26, R27, R29, R30, R30½ and R31

All the following Cases are made of heavy black sole leather, hand sewed throughout and handsomely ornamented with embossing. They are lined with fleeced flannel, have pocket for attachments, leather handle and straps and fine nickel-plated trimmings.

No.		Each	No.	Each
R20	—For E _b Alto Valve Trombone, Short Model.....	\$9.00	R25	—For Upright E _b Alto \$ 9.00
R20½	—For E _b Alto Valve Trombone, Long Model.....	9.00	R26	—For Upright B _b Tenor 9.50
R21	—For B _b Tenor Valve Trombone, Short Model.....	9.00	R27	—For Upright B _b Baritone 11.00
R21½	—For B _b Tenor Valve Trombone, Long Model.....	9.00	R29	—For Upright B _b Bass 12.00
R22	—For Solo or Bell Front Alto, Satchel Form.....	4.50	R30	—For Upright E _b Bass or Tuba 17.50
R23	—For Circular Alto or Mellophone.....	9.50	R30½	—For Upright E _b Bass, monster pattern 22.50
R24	—For Slide Trombone.....	8.50	R31	—For Upright BB _b Bass, monster size..... 27.50

DIAGRAMS SHOWING HOW TO MEASURE WHEN ORDERING BAND INSTRUMENT CASES

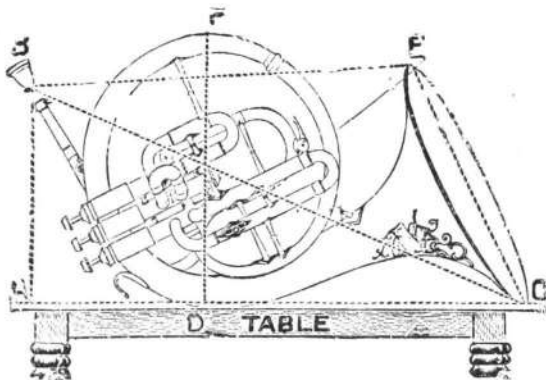

For Mellophones or Concert Altos, Ballad Horns and French Horns, give the following measurements: A to C, A to B, C to E, D to F, B to E, B to C. State thickness through valves, also give make of instrument.

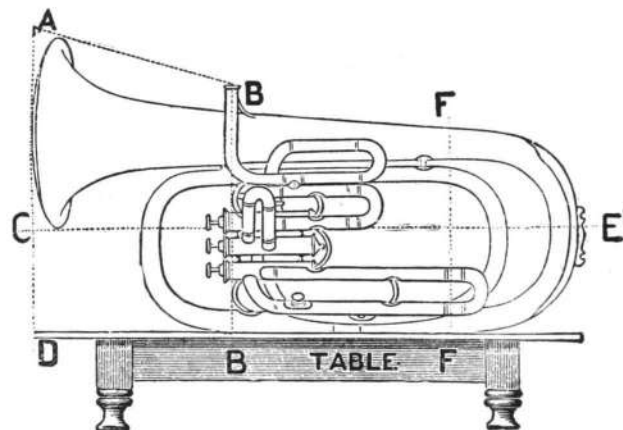

For all Upright Instruments give the following measurements: A to B, A to C, A to D, B to B, F to F, C to E. State thickness through valves, also give make of instrument.

BAND INSTRUMENT CASES—SIDE OPENING



No. R124—Slide Trombone Case

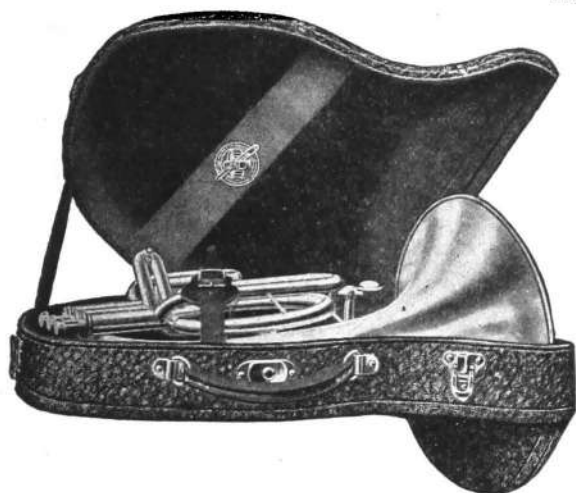

No. R123—Mellophone Case

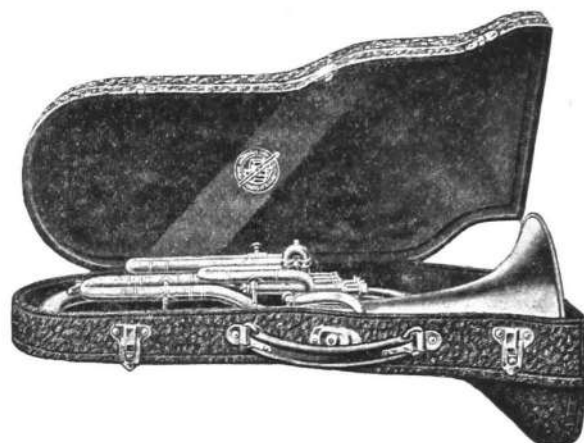

Nos. R125 and R127

DIAGRAM SHOWING HOW TO MEASURE WHEN ORDERING VALVE AND SLIDE TROMBONE CASES

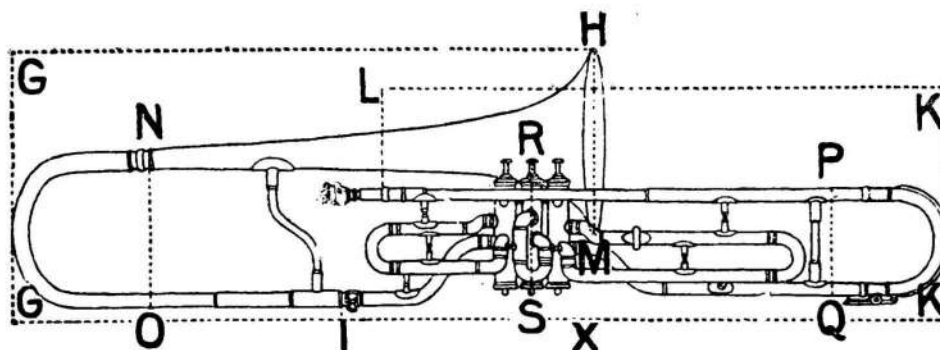

For Valve Trombone Cases give the following measurements: G to H, G to I, H to M, L to K, K to I, N to O, P to Q, R to S, H to X. Give thickness through valves, also make of instrument. For Slide Trombone Cases, give same measurements as above except R to S.

The following Cases are all made of 3-ply wood veneer, covered with genuine black seal grain leather, and lined with a fine quality of silk plush. Locks, Catches, Handle Fasteners and Studs all heavily nickel plated

No.		Each
R123	—For Mellophone or Concert Horn, silk plush lined.....	\$12.50
R124	—For Slide Trombone, silk plush lined (state size of bell).....	12.00
R125	—For E _b Alto, silk plush lined.....	12.50
R121	—For B _b Tenor Valve Trombone, silk plush lined.....	12.50
R121½	—For Combination Valve and Slide Trombone, silk plush lined	15.00
R127	—For B _b Baritone, silk plush lined.....	15.00
R127½	—For Double Bell Euphonium, silk plush lined.....	17.50

NOTE.—Our stock of Side-opening Cases is made for Holton Instruments and other standard models. Cases specially made to order upon receipt of measurements, as per diagram, require from three to six weeks' time. To insure a satisfactory fit, send diagram with each order.

BAND INSTRUMENT FURNISHINGS

SHANKS, CROOKS, KEYS, SPRINGS, FINGER BUTTONS, ETC.

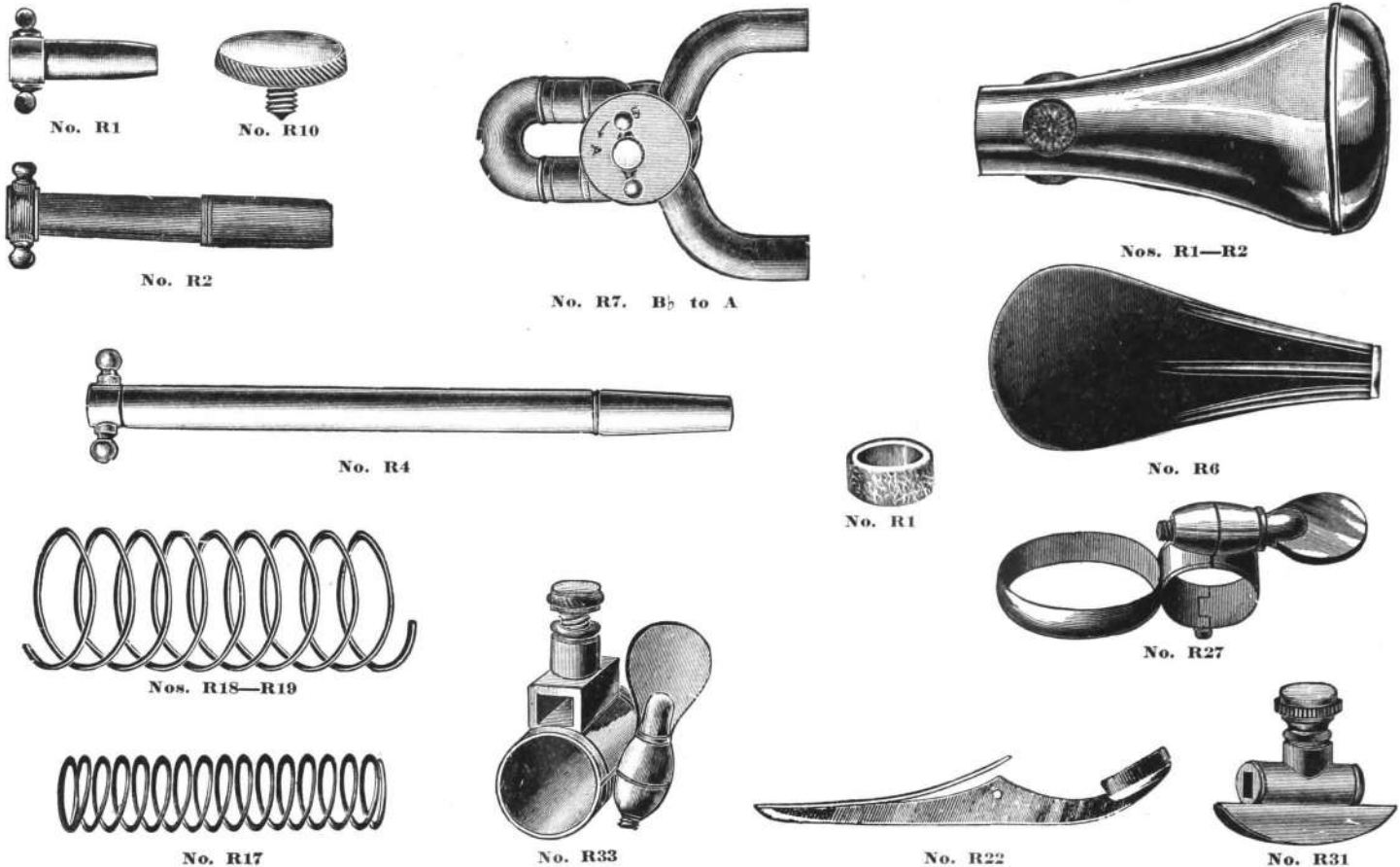

SHANKS AND CROOKS		--Each--			
No.	Description	Brass	Nickel	Silver	Postage
R 1	Tuning Bit, Short, Plain Pattern for Bb Cornet.	\$0.25	\$0.35	\$0.50	1 ct.
R 2	Bb Shank, or Set Piece, Plain for Bb Cornet	.35	.45	.65	2 cts.
R 3	Low Pitch Slide for Bb Cornet.	3.00	3.50	4.00	4 cts.
R41	Low Pitch Slide for Alto, with Water Key.	4.00	4.75	5.50	1-lb. rate
R41½	Low Pitch Sleeves for Alto.	1.75	2.00	2.25	4 cts.
R42	Low Pitch Slide for Mellophone, with Water Key.	4.25	5.00	5.75	
R43	Low Pitch Slide for Trombone.	4.00	5.00	6.00	
R43½	Low Pitch Sleeves for Trombone.	2.00	2.25	2.75	
R44	Low Pitch Slide for Tenor with Water Key.	4.75	5.75	6.25	
R45	Low Pitch Slide for Baritone or Bb Bass with Water Key.	4.75	5.75	6.50	All take
R45½	Low Pitch Sleeves for Baritone or Bb Bass.	2.00	2.25	2.75	1-lb. rate
R46	Low Pitch Slide for Eb Bass, with Water Key.	6.50	7.50	8.50	
R46½	Low Pitch Sleeves for Eb Bass.	2.00	2.25	3.00	
R47	Low Pitch Slide for Bbb Bass, with Water Key.	8.50	9.75	10.75	
R47½	Low Pitch Tubes for Bbb Bass.	2.50	3.50	4.25	
R 4	A Shank or Set Piece, Plain, for Bb Cornet.	.50	.60	.90	3 cts.
R 7	Bb to A. Instantaneous change for Cornet. This is a very convenient addition to any Bb Cornet, and especially so for soloists. The supplementary tubing, which is connected with the regular tuning slide by a rotary valve, throws the instrument into "A" by simply turning the button in the center of the valve, and back again when needed. This can be done in an instant, and is often, in orchestra music or solo playing, of the utmost importance.	6.00	6.50	7.00	1-lb. rate
R7B	C Attachment for Bb Cornet. A "C" attachment for Bb Cornet must be made strictly to order and carefully fitted to each individual Cornet, and the valve slides must be shortened so that a perfect scale can be played. It is therefore necessary that a Cornet requiring a "C" attachment be sent to us in order that the work may be properly done.	6.00	6.50	7.50	1-lb. rate
R 9	Trill Valve, for Slide Trombone, with necessary tubing. Cost of attaching to instrument.	8.00	8.75	9.75	1-lb. rate 1.50 additional

MUTES		Each	Postage
R 1	Cornet Mute, Brass, Fit any Cornet.	\$1.00	
R 2	Cornet Mute, Nickel, Fit any Cornet.	1.25	1-lb. rate
R 3	Cornet Mute, Silver, Fit any Cornet.	2.00	
R 4	Cornet Mute, Long Model, Leather Pulp, Holton Make, Fit any Cornet.	1.50	4 cts.
R 5	Trombone Mute, Leather Pulp, Holton Make, Fit any Trombone.	1.75	
R 6	"El-Co" Cornet or Trumpet Mute, Leather, with tuning device. Thoroughly practical. Used in Chicago Symphony Orchestra.	3.75	1-lb. rate
VALVE CORKS		Per Set	
R 1	Circular, with Hole.	\$0.10	1 ct.
VALVE SPRINGS		Per Set	
R17	Valve Springs for Cornets, Below Pistons, German Silver.	\$0.20	1 ct.
R18	Valve Springs, for Altos, German Silver.	.25	1 ct.
R18½	Valve Springs for Tenors, German Silver.	.25	1 ct.
R19	Valve Springs for Baritones and Basses, German Silver.	.25	1 ct.
R25	Valve Springs for Cornets, inclosed at Top, German Silver.	.25	1 ct.
R81	For Cornet, Silver Plated, Holton Make.	.20	1 ct.
R83	For Alto, Silver Plated, Holton Make.	.30	1 ct.
R85	For Baritone, Silver Plated, Holton Make.	.30	1 ct.
R87	For Bass, Silver Plated, Holton Make.	.30	1 ct.
ADJUSTABLE FINGER RING		Each	
R27	Brass, can be fastened to tubing in any position.	\$0.75	3 cts.
R28	Same, Nickel Plated.	.90	3 cts.
R29	Same, Silver Plated.	1.25	3 cts.
FINGER BUTTONS		Each	
R10	German Silver, Plain for Cornets.	\$0.10	2 cts.
R11	German Silver, Plain, assorted sizes, for all other instruments	.10	3 cts.
R12	Silver Plated, Pearl Top, for Cornets.	.50	3 cts.
R13	Silver Plated, Pearl Top, assorted sizes, for all other instruments.	.55	3 cts.
R95	Brass, Milled Edge, Pearl Top, Holton Make.	per Set 1.25	3 cts.
R97	Silver Plated, Milled Edge, Pearl Top, Holton Make, per Set	1.75	3 cts.
WATER KEYS		Each	
R22	Single Water Key, Brass, for all Piston Valve Instruments.	\$1.00	2 cts.
MUSIC RACK HOLDERS		Each	
R31	Brass Plate and Socket with Adjustable Screw to Solder on Tubing.	\$0.35	2 cts.
R33	Brass Adjustable Hinged Ring with Screw; a very convenient arrangement, as the Music Holder can be placed at any desired distance from the eyes, or in various positions on the instrument.	1.00	3 cts.

BAND INSTRUMENT FURNISHINGS

MOUTHPIECES, MUSIC RACKS, BAND LAMPS, VALVE AND SLIDE OIL, POLISH, ETC.

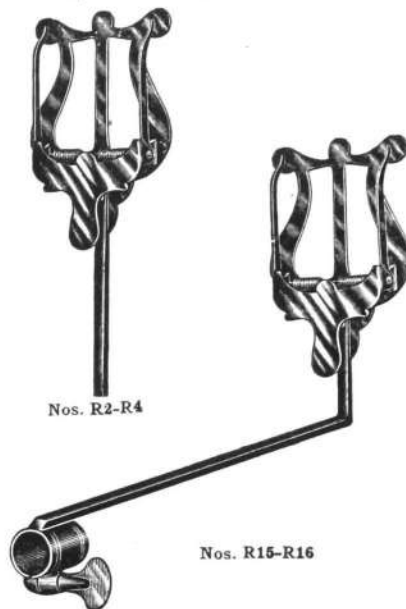
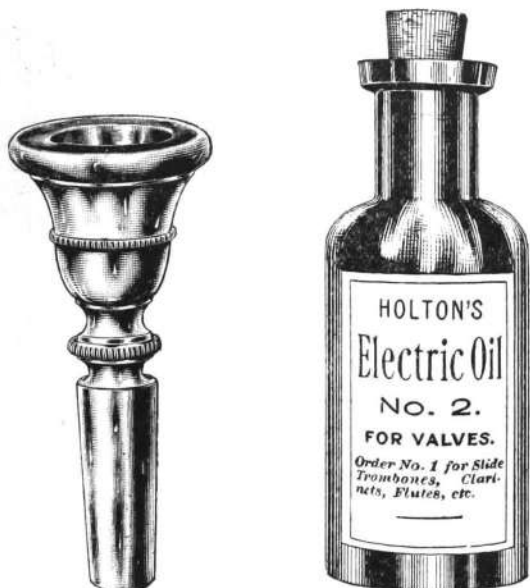

No.		MOUTHPIECES	Each		Postage
		Best French Model	German Silver	Silver Plated	
R 1	For Eb Cornet		\$0.50	\$0.75	4 cts.
R 2	For Bb Cornet		.50	.75	4 cts.
R 3	For Eb Alto		.75	1.00	
R 4	For Bb Tenor		.90	1.25	
R 5	For Bb Bari one		1.00	1.40	
R 6	For Bb Bass		1.25	1.50	
R 7	For Eb Bass		1.40	1.75	
R 7 1/2	For Bb Bass		1.60	2.00	All take 1-lb. rate
R 8	For Eb Alto Trombone		.75	1.00	
R 9	For Bb Tenor Trombone		.90	1.25	
R10	For French Horn		.75	1.00	
R11	For Bugle (brass only)		.25		3 cts.
R11 1/2	For Trumpet (brass only)		.25		4 cts.
R12	For French Horn, genuine Schmidt make		3.00		4 cts.

No.		METAL POLISH	Each
R 6	Stabrite, Half Pint Can		\$0.25 1-lb. rate
R 7	Stabrite, Pint Can		.50 2-lb. rate
R 8	Holton's Silv Arine		.25 1-lb. rate

For all metal surfaces; will not scratch; works quickly and produces highest possible polish.

No.		SLIDE AND VALVE OIL AND SALVE	Per Bottle
R 1	Holton's Oil for Slides		\$0.25 1-lb. rate
R 2	Holton's Oil for Valves		.25 1-lb. rate
R 3	Holton's Electric Slide Salve		.15 3 cts.

No.		MOUTHPIECES	Each		Postage
		Holton's American Make			
R61	For Cornet, Silver Plated		\$1.25		4 cts.
R62	For Cornet, Gold Plated		2.00		4 cts.
R62 1/2	For Cornet, Concave Rim, Silver Plated		3.00		4 cts.
R62 3/4	For Cornet, Concave Rim, Gold Plated		4.00		4 cts.
R64	Combination Mouthpiece for Cornet and Trumpet; one interchangeable Rim screwing on Cornet and Trumpet Stems, Silver Plated		3.00		
R63	For Alto, Silver Plated		1.50		
R65	For Mellophone, Silver Plated		1.50		
R67	For Tenor, Silver Plated		1.65		
R69	For Slide Trombone, Silver Plated		1.65		All take 1-lb. rate
R71	For Valve Trombone, Silver Plated		1.65		
R73	For Baritone, Silver Plated		1.65		
R75	For Bb Bass, Silver Plated		2.00		
R77	For Eb Bass, Silver Plated		2.25		
R79	For Bb Bass, Silver Plated		2.50		

Holton Cornet Mouthpieces can be supplied in all well known models, such as Besson, Courtois, Boston, Levy, Crean, Austin, Peterson, Bert Brown, Fred Clements, Anderson, etc. Slide Trombone Mouthpieces in Pryor, Courtois, Warren, Stacy, Innes, Besson, Simons and all other standard models.

No.		MUSIC RACKS	Each
R 2	Horn Rack, Brass, Square Shank		\$0.40 4 cts.
R 4	Horn Rack, Nickel, Square Shank		.50 4 cts.
R15	Slide Trombone Rack, Brass		.75
R16	Slide Trombone Rack, Nickel		1.00
R17	Slide Trombone Rack, Brass, Holton Make		.85
R18	Slide Trombone Rack, Silver Plated, Holton Make		1.25

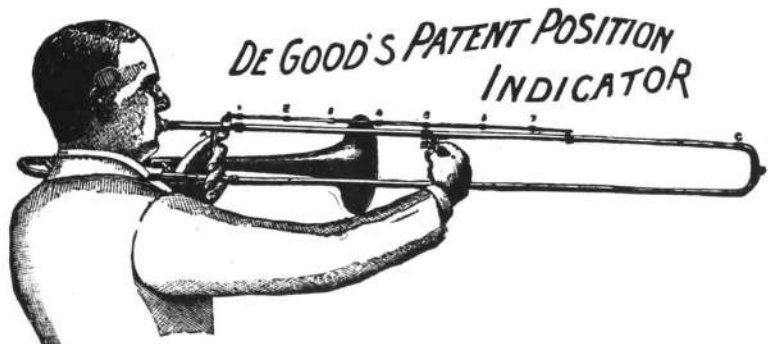

DE GOOD'S PATENT POSITION INDICATOR
 Every Position Plainly Indicated. Can be Attached or Detached in a Few Seconds.
 No. 1 Complete, with instructions showing how to attach \$3.00 1-lb. rate

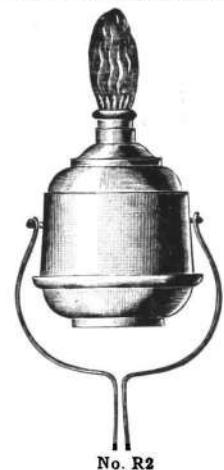

BAND LAMPS
 No. R 2 Hand Spun Brass, Heavily Nickel Plated; complete with Socket for Cap and Wick; Can Airtight, no leakage in transportation when not in use.
 Single Lamps \$0.30 1-lb. rate
 Per Dozen 3.00

In addition to the above furnishings we carry a very large assortment of genuine Holton, Besson, Courtois and other makes of mouthpieces, springs, finger buttons and sundry trimmings. We also manufacture especially to order in our own shops crooks of all kinds not listed above and can furnish anything wanted in the nature of repair parts.

"AMERICAN PERFECTION" SAXOPHONES

(AMERICAN MAKE)

LOW OR INTERNATIONAL PITCH ONLY

In the "American Perfection" Saxophones we offer instruments which, while modestly priced by comparison, we conscientiously believe to be fully the equal of the best of their class. In their construction faults which exist in the body part of most other makes have been corrected with very appreciable results upon the tone. The "American Perfection" will not squawk or warble in the lower register, but is of just as clear and pleasing tone character as in the upper.

The Key arrangement represents the very latest improvements to be found on other makes, together with the addition of many exclusive features of our own special design and construction. The keys are conveniently arranged to facilitate rapid execution with the minimum amount of effort and the mechanism is substantial and correctly built. The single action octave key is recognized as a great improvement by professional and amateur alike. In playing the scale on a Saxophone equipped with the old-style double-action octave key, it is necessary after making G to change the thumb to another register key. This is awkward and difficult when rapid execution is attempted. On the "American Perfection," however, the single action automatic octave key entirely overcomes this—the thumb is not shifted to another key, but remains in its natural position and the mechanism is arranged to make the change automatically from one octave to the other and as a result the manipulation of the keys becomes as easy as on an ordinary Clarinet. The posts or key supports on all "American Perfection" Saxophones are securely brazed to separate plates before being assembled and fastened to the body of the instrument, giving such strength and stability to the key mechanism as will withstand all ordinary wear and use. The pad receivers or cups are of the oval style of construction, which makes it possible to fit a pad that covers perfectly and does not bulge in the center.

Every "American Perfection" Saxophone is equipped with single action automatic octave key and is supplied with mouthpiece, mouthpiece cap, reed holder and patent leather shoulder strap.



No. R100½—B_b Soprano No. R101½—E_b Alto No. R1002½—C Melody No. R102½—B_b Tenor No. R103½—E_b Baritone

No.	Brass	Silver Plated
R 100½—B _b Soprano, Low Pitch.....	\$56.00	\$ 80.00
R 101½—E _b Alto, Low Pitch.....	58.00	85.00
R 102½—B _b Tenor, Low Pitch.....	65.00	92.50
R1002½—C Melody, Low Pitch.....	65.00	92.50
R 103½—E _b Baritone, Low Pitch.....	85.00	115.00

Description of Silver-plated Finish: Quadruple silver plate, Velvet Finish, keys and points burnished, artistically engraved, inside of bell gold plated and burnished.

"American Perfection" Saxophones are shipped anywhere with the privilege of 10 days' trial. Return transportation charges at our expense if not satisfactory. Easy terms.

COUESNON & CIE., PARIS, SAXOPHONES

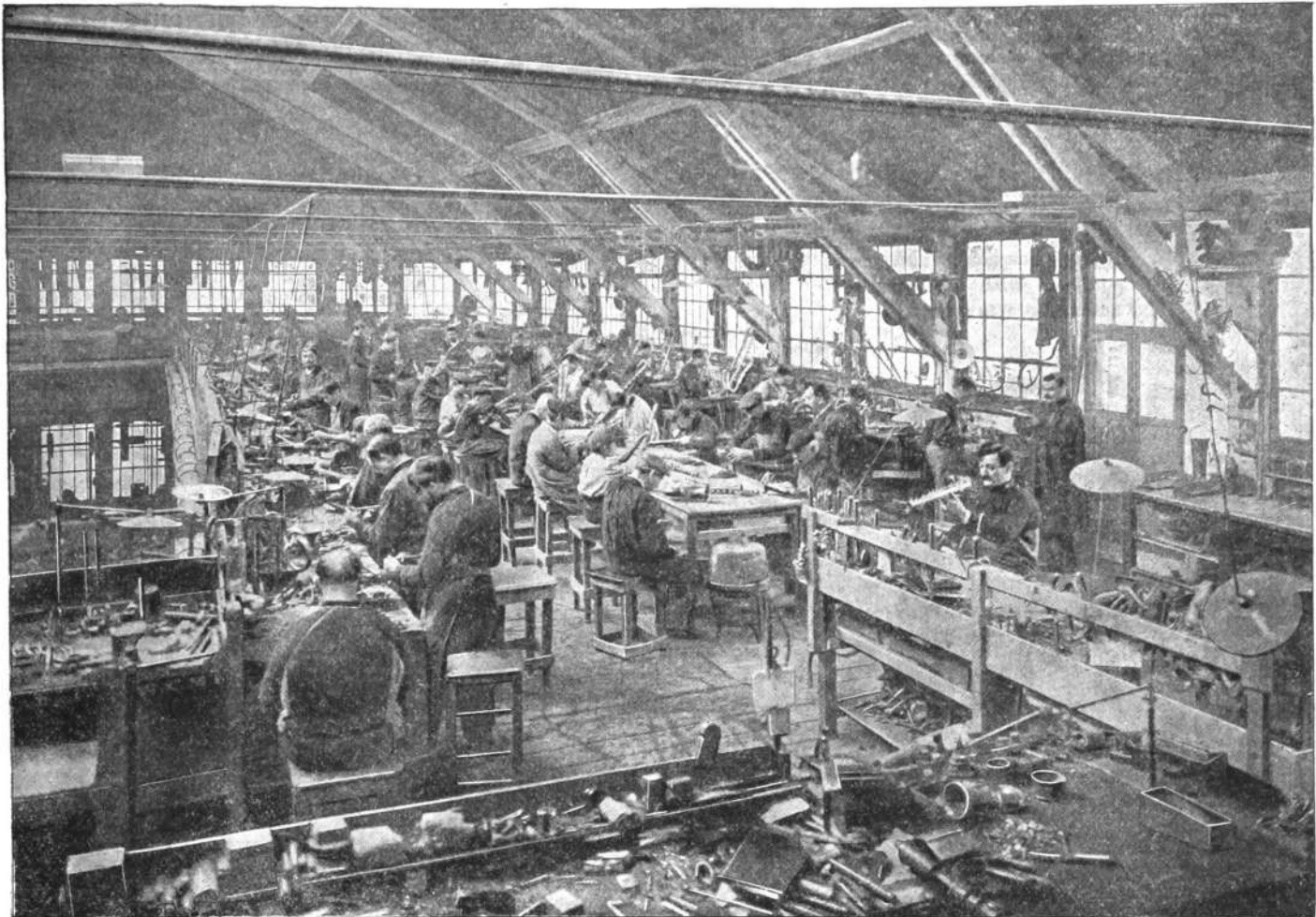

Saxophone Department Couesnon & Cie.'s Chateau-Thierry factory.

INFORMATION OF INTEREST TO THE INTENDING SAXOPHONE PURCHASER

The Soprano Saxophone in $B\flat$ is a solo instrument and is used in both band and quartet work.

The Alto Saxophone in $E\flat$ is the most popular instrument for solo work, although the Soprano in $B\flat$ and the Tenor in $B\flat$ are also frequently used.

The C Melody Saxophone is very effective for leading the choir in church services or at home in conjunction with organ or piano. It is also occasionally used in orchestra in place of the Cello. It cannot be used to advantage in quartet work—the $B\flat$ Tenor is recommended instead. The tone of the Melody Saxophone more closely resembles the human voice than any other instrument made.

The Tenor Saxophone in $B\flat$ is a solo instrument and it can be used singly to advantage in band work. It is an essential and most necessary instrument in the Saxophone quartet.

The Baritone Saxophone in $E\flat$ can be used as a solo instrument and is very effective, particularly in vaudeville. It is an ideal and essential instrument for melody and quartet work.

The Alto Saxophone in $E\flat$ and the Tenor in $B\flat$ are being successfully used to replace or supplement the Upright Alto, Mellophone, and Baritone, as well as the Bassoon, the Alto and Bass Clarinets,—also used singly and in quartet form in conjunction with the regular instruments.

The introduction of one or two Saxophones in a band soon proves that they are just the part that has been lacking and they are usually followed by the other models to complete the set.

The scale range or compass of each Saxophone extends through about two and one-quarter octaves. In the hands of good players it can be extended an octave higher than the natural range of the instrument.

The range of the $B\flat$ Soprano Saxophone is $E\flat$ above the staff to $B\flat$ below the staff. Of the $E\flat$ Alto, from F natural above the staff to $B\flat$ below. Of the Melody in C, from F natural above the staff to $B\flat$ below. Of the $B\flat$ Tenor, from F natural above the staff to $B\flat$ below. Of the $E\flat$ Baritone, from $E\flat$ above the staff to $B\flat$ below.

COUESNON & CIE., PARIS, SAXOPHONES

(Modèle de Conservatoire)

WE ARE SOLE WESTERN UNITED STATES AGENTS FOR COUESNON & CIE. SAXOPHONES

Couesnon Saxophones are manufactured under the personal supervision of A. Mayeur, soloist of the Paris Opera, recognized as the world's greatest saxophonist, and his certificate as to playing qualities and workmanship accompanies each instrument.

Every Couesnon Saxophone is equipped with single action automatic octave key.



Nos. R0, R0¹/₂



Nos. R1, R1¹/₂



Nos. R2, R2¹/₂



Nos. R3, R3¹/₂

HIGH OR LOW PITCH

Couesnon & Cie. Saxophones are used exclusively by the famous Garde Republicaine Band of Paris and by leading soloists all over Europe. They are equipped with Automatic Single Octave Key, enabling the player to pass from high G, or other notes where the octave key is used, to the higher notes without changing the thumb key of the left hand. Furnished also with an extra thumb key, so that low C can be played with either thumb or little finger of right hand; Double B_b Key, additional Shake Key from B to C, Double F Sharp, Trilling Key from B natural, C natural, C sharp to E_b; G sharp articulated, Low B_b Key, Roller Keys.

Every Couesnon Saxophone is furnished with mouthpiece, reed holder and reed, mouthpiece cap, patent leather strap and music rack.

No.		Brass	Silver Plated
R 0	—B _b Soprano (Alto Shape), High Pitch.....	\$70.00	\$ 91.00
R 0 ¹ / ₂	—B _b Soprano (Alto Shape), Low Pitch	70.00	91.00
R 1	—E _b Alto, High Pitch.....	75.00	96.00
R 1 ¹ / ₂	—E _b Alto, Low Pitch	75.00	96.00
R 2	—B _b Tenor, High Pitch.....	75.00	97.50
R 2 ¹ / ₂	—B _b Tenor, Low Pitch	75.00	97.50
R200	—C Tenor or Melody Saxophone, High Pitch.....	75.00	97.50
R200 ¹ / ₂	—C Tenor or Melody Saxophone, Low Pitch	75.00	97.50
R 3	—E _b Baritone, High Pitch.....	85.00	112.50
R 3 ¹ / ₂	—E _b Baritone, Low Pitch	85.00	112.50

For gold plating inside of bell, add to list price: Soprano, \$3.50; Alto, \$4.25; Tenor, \$5.00; Baritone, \$5.50

See page 58 for prices on Leather Saxophone Cases

Ten days trial allowed on Couesnon Saxophones. No obligation to purchase if not thoroughly satisfied. Return transportation charges at our expense. Easy monthly payments.

BUFFET, CRAMPON & CO., SAXOPHONES



Latest Improved Patent Keys Added to the Evette & Schaeffer System:

First—A new key for the upper E and F. Upon the ordinary saxophone the notes E and F above the staff are obtained by using simultaneously three or four keys, and in order to grasp these keys, the hand loses its natural

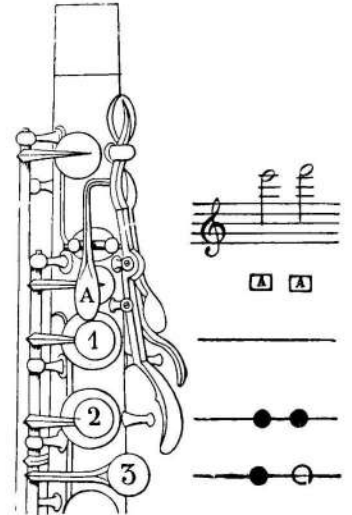

position which causes much trouble in the execution of rapid passages. With the new key here illustrated the difficulty is entirely overcome, as will be seen in the above examples.

The key A when pressed down closes the pad of the first finger and dispenses with the other keys. Thus it is very plain to see the great advantage gained by this new system of fingering.

This key is used only on the alto and tenor saxophones. Second—A new E_b key that is applied to all saxophones.

Nos. R10, R10½

Nos. R11, R11½

Nos. R12, R12½

Nos. R13, R13½

Every Buffet Saxophone Equipped with Single Action Automatic Octave Key.

Evette & Schaeffer's system is P. Goumas & Co's system with addition of one F sharp shake key, also a plate for the first finger of the left hand for a new B_b, and a new patent system at the G sharp key for shake G sharp with all the other notes, and the extra patent key for going down to low B_b, with new E_b key, and with double C sharp, B natural and B_b keys for the middle finger of the right hand. The alto and tenor with the new E and F natural keys.

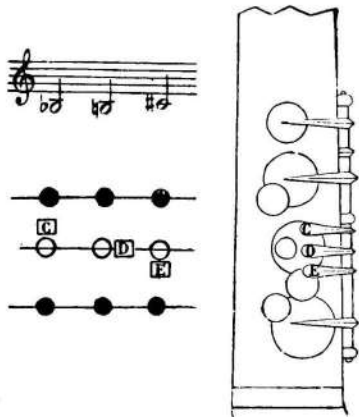

The passing from B natural, C, C sharp to E_b is very difficult upon all saxophones, requiring much practice to render it smoothly, and although many contrivances have been tried to remedy this, they have signally failed. It remained for the Messrs. Evette & Schaeffer to overcome this objectionable feature by the introduction of a new key which permits the emission of the E, through the hole of the E natural. This is done by pressing down the 5 bis pad with the second finger of the right hand and raising the third finger. The little finger, which ordinarily takes the E natural key, thus remains free and the passing from B natural, C, C sharp to E_b becomes quite easy.

Both of these improvements are duly patented and protected in all countries, and saxophonists should avail themselves of them, for the facilities afforded over the old style of fingering need no eulogizing. They tell their own story.

Third—A still later improvement enables the performer to make the tones B_b, B natural and C sharp low (that are usually made with the fourth finger of the left hand) with the second finger of the right hand.

By means of the levers C, D and E these tones are easily produced, thus simplifying passages that were heretofore deemed very difficult or impossible.

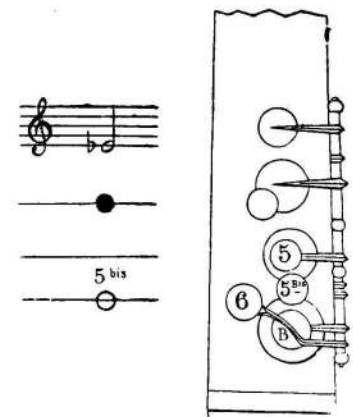

Mouthpiece, Mouthpiece Cap, Reed Holder and Reed with each instrument. Patent leather shoulder strap with Alto, Tenor and Baritone.

No.		Brass.	Silver Plated.
R10	—E _b soprano, high pitch.....	\$ 82.50	\$100.00
R10½	—B _b soprano, low pitch.....	82.50	100.00
R11	—E _b alto, high pitch.....	95.00	116.00
R11½	—E _b alto, low pitch.....	95.00	116.00
R12	—B _b tenor, high pitch.....	95.00	117.50
R12½	—B _b tenor, low pitch.....	95.00	117.50
R13	—E _b baritone, high pitch.....	100.00	127.50
R13½	—E _b baritone, low pitch.....	100.00	127.50

The heaviest quadruple plate, satin finish, is supplied. Prices on burnished finish, also on nickel plate, submitted on application. Satin finish instruments have inside of bell burnished. For gold plating inside of bell, add—soprano, \$3.50; alto, \$4.25; tenor, \$5.00; baritone, \$5.50. See following page for prices on Leather Saxophone Cases.

SAXOPHONE CASES AND FURNISHINGS

SAXOPHONE CASES



Nos. R3½—R4—R5—R6

No.		Each
R3	—Seal Grain Leather Covered, Lined with Velvet, Patent Nickel Catches and Lock, Compartment Inside for Attachments. For B _♭ Soprano Saxophone, Straight Shape.....	\$ 9.00
R3½	—Seal Grain Leather Covered, Lined with Velvet, Inside Compartment for Attachments, Patent Nickel Catches and Locks. Hand Sewed throughout. Well made and substantial. For B _♭ Soprano Saxophone, Alto shape.....	11.00
R4	—Same description as No. R3½, but for E _♭ Alto Saxophone.....	12.00
R5	—Same description as No. R3½, but for B _♭ Tenor Saxophone.....	15.00
R5½	—Same description as No. R3½, but for C Tenor Saxophone.....	15.00
R6	—Same description as No. R3½, but for E _♭ Baritone Saxophone.....	18.00

Our Saxophone Cases are made to fit Buffet, Couesnon & Cie. and American Perfection Models. Others to order. Send paper pattern, dimensions and bell measurement.

MOUTHPIECES With Reed Holders

No.		Each	Postage
R14	—B _♭ Soprano, Couesnon & Cie.....	\$2.00	All take 1 lb. rate.
R15	—E _♭ Alto, Couesnon & Cie.....	2.00	
R16	—B _♭ Tenor, Couesnon & Cie.....	3.00	
R17	—E _♭ Baritone, Couesnon & Cie.....	3.50	
R20	—B _♭ Soprano, Buffet, Crampon & Co.....	2.50	
R21	—E _♭ Alto, Buffet, Crampon & Co.....	4.00	
R22	—B _♭ Tenor, Buffet, Crampon & Co.....	4.25	
R23	—E _♭ Baritone, Buffet, Crampon & Co.....	4.75	

REED HOLDERS

No.		Each	Postage
R25	—Brass, with Adjusting Screw, for Soprano.....	\$0.40	2 cts.
R26	—Brass, with Adjusting Screw, for Alto.....	.50	2 cts.
R27	—Brass, with Adjusting Screw, for Tenor.....	.60	3 cts.
R28	—Brass, with Adjusting Screw, for Baritone.....	.75	3 cts.

MOUTHPIECE CAPS

No.		Each	Postage
R30	—Metal, Nickel Plated, for B _♭ Soprano.....	\$0.40	2 cts.
R31	—Metal, Nickel Plated, for E _♭ Alto.....	.50	3 cts.
R32	—Metal, Nickel Plated, for B _♭ Tenor.....	.60	3 cts.
R33	—Metal, Nickel Plated, for E _♭ Baritone.....	.75	4 cts.

REEDS

No.		Each	Dozen	Postage per doz.
R36	—B _♭ Soprano, Couesnon & Cie.....	\$0.15	\$1.60	2 cts.
R37	—E _♭ Alto, Couesnon & Cie.....	.15	1.60	2 cts.
R38	—B _♭ Tenor, Couesnon & Cie.....	.20	2.25	2 cts.
R39	—E _♭ Baritone, Couesnon & Cie.....	.25	2.75	2 cts.
R40	—B _♭ Soprano, Buffet, Crampon & Co.....	.20	2.25	2 cts.
R41	—E _♭ Alto, Buffet, Crampon & Co.....	.25	2.75	2 cts.
R42	—B _♭ Tenor, Buffet, Crampon & Co.....	.30	3.25	2 cts.
R43	—E _♭ Baritone, Buffet, Crampon & Co.....	.35	3.75	2 cts.

REED CASES

No.		Each
R15	—Solid leather, black or russet, pocketbook style, with glass to protect reeds.....	\$0.60
R16	—Leather covered veneered wood box, plush lined, nickel lock, glass compartment for six reeds.....	1.00

Postage on R15 and R16, 1-lb. rate.

PADS

No.		Per set	Postage
R50	—Kid covered, full set for B _♭ Soprano.....	\$1.25	2 cts.
R51	—Kid covered, full set for E _♭ Alto.....	1.25	2 cts.
R52	—Kid covered, full set for B _♭ tenor.....	1.25	3 cts.
R53	—Kid covered, full set for E _♭ Baritone.....	1.25	3 cts.

BASSOONS AND FURNISHINGS

BUFFET, CRAMPON & CO., PARIS
(Evette & Schaeffer, Successors)

Low Pitch Only

Rosewood, German Silver Keys. Pipe or small joint lined with rubber to prevent cracking.

No.		Each
R2	—Rosewood, 17 German silver keys, with long key for the little finger of the left hand to close the vent hole for the lower notes, with addition of a key for the thumb to shake from E natural to F sharp.....	\$110.00
R4	—Rosewood, 18 German silver keys. In addition to the mechanism of No. R2, the 18th key is added to the lower joint for the second finger of the right hand, and is used to shake from C natural to D flat; also D natural and E flat, between and above the lines, the upper G natural with the A natural, and A natural with the B flat. This key is numbered No. 20, on the scale of E. Jancourt. Fitted with movable cork.....	\$120.00

BASSOON REEDS



No.		Each	Postage
R3	—Buffet, wrapped joint, finest quality.....	\$0.75	2 cts.
R2	—Karl Mayer, philharmonic, finest quality.....	1.25	2 cts.



No. R2



No. R4

JEAN MARBEAU CLARINETS

Low priced but guaranteed accurate in the scale and of excellent tone quality. Polished finish ebony, burnished German silver keys, cork joints. Every instrument furnished with mouthpiece, reed holder and reed, and mouthpiece cap.

Jean Marbeau Clarinets are being used by the thousand in amateur and semi-professional bands and orchestras and they have never been found deficient in any respect for such service. They are accurately in pitch, either High or Low, and are warranted correct in intonation.

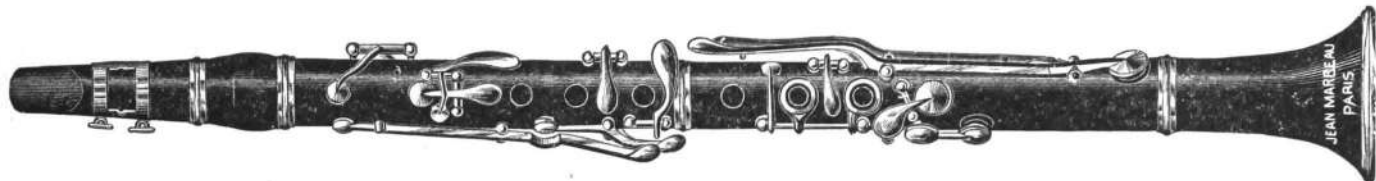

Nos. R80, R80 $\frac{1}{2}$

Ebony, polished finish, 13 German silver keys, 2 rings, German silver trimmed, Albert System and trill keys. Furnished with mouthpiece, mouthpiece cap, reed holder and reed, cork joints.

HIGH PITCH		LOW PITCH	
No.	Each	No.	Each
R80A—Key of A	\$14.00	R80 $\frac{1}{2}$ A—Key of A	\$14.00
R80B—Key of B \flat	14.00	R80 $\frac{1}{2}$ B—Key of B \flat	14.00
R80C—Key of C	14.00	R80 $\frac{1}{2}$ C—Key of C	14.00
R80E—Key of E \flat	14.00	R80 $\frac{1}{2}$ E—Key of E \flat	14.00

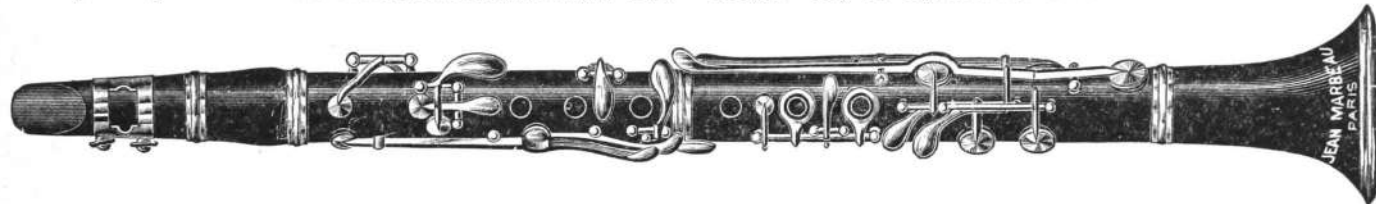

Nos. R81, R81 $\frac{1}{2}$

Ebony, polished finish, 15 German silver keys, 2 rings, German silver trimmed, Albert System, with double C sharp key to trill B natural to C sharp, and C sharp to D sharp. Furnished with mouthpiece, mouthpiece cap, reed holder and reed, cork joints. The 15-key Clarinet is more desirable than the 13-key instrument as the two extra keys afford greater facility in trilling and cross-fingering.

HIGH PITCH		LOW PITCH	
No.	Each	No.	Each
R81A—Key of A	\$17.50	R81 $\frac{1}{2}$ A—Key of A	\$17.50
R81B—Key of B \flat	17.50	R81 $\frac{1}{2}$ B—Key of B \flat	17.50
R81C—Key of C	17.50	R81 $\frac{1}{2}$ C—Key of C	17.50
R81E—Key of E \flat	17.50	R81 $\frac{1}{2}$ E—Key of E \flat	17.50

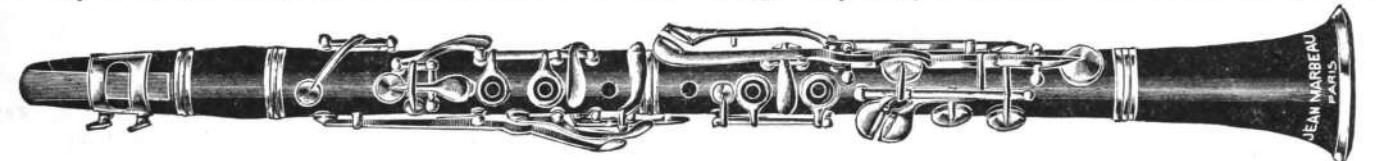

Nos. R82—R82 $\frac{1}{2}$

Ebony, polished finish, 15 German silver keys, 4 rings, German silver trimmed, Albert System, with trill keys C and B, an E \flat key for trilling F sharp and C sharp, with hard rubber roller keys for the little finger of both hands. Furnished with mouthpiece, mouthpiece cap, reed holder and reed, cork joints. The most popular style Clarinet for band work.

HIGH PITCH		LOW PITCH	
No.	Each	No.	Each
R82A—Key of A	\$22.50	R82 $\frac{1}{2}$ A—Key of A	\$22.50
R82B—Key of B \flat	22.50	R82 $\frac{1}{2}$ B—Key of B \flat	22.50
R82C—Key of C	22.50	R82 $\frac{1}{2}$ C—Key of C	22.50
R82E—Key of E \flat	22.50	R82 $\frac{1}{2}$ E—Key of E \flat	22.50

SUGGESTIONS FOR THE PROPER CARE OF CLARINETS, FLUTES AND SIMILAR WOODEN INSTRUMENTS

As these instruments are liable at any time to crack, unless properly cared for, a few words as to their preservation may be of service.

Should an instrument suddenly check, without seeming cause, do not at once conclude that it was never of any account and that the first thing to be done is to "blow up" the party from whom it was purchased, because he or they had not a particle more to do with the calamity than its present owner, and are not one iota more responsible for it. Undoubtedly had the instrument received such attention as is here recommended no accident would have occurred—therefore bear the following suggestions in mind and prevent future annoyance and loss.

The finest instruments can be quickly ruined by being put away after use without being wiped out.

Every player should possess a wiper made of either worsted or silk, and when through playing should wipe the instrument dry inside, then apply a small quantity of oil—sweet oil is good—not too much, but just enough to leave a slight gloss in the bore. A very nice way is to have a second wiper for applying the oil, though one can be used for both purposes if the second is not convenient.

Dry the outside of the instrument with a rag or chamois skin and be careful to wipe the ends of the joints dry.

Keep the instrument in as even a temperature as possible. A very warm or very cold room is extremely dangerous, the latter especially so to ivory mounted instruments.

To a new instrument, or one that has been out of use for some time, a little oil should be applied daily for the first five or six days—after which once a week is sufficient—unless it be in a warm, dry climate or during very warm weather, when twice a week would insure greater safety. Always oil after using, not before.

Never lay an instrument down, after using, upon a cold substance like a marble slab or mantelpiece, nor leave it in a much colder room than the one in which it has just been used, nor go out into a cold temperature without being sure to wipe dry and put into a warm case. If an instrument has not a regularly made cloth or chamois skin lined case, the joints should each be wrapped separately in a piece of flannel or skin in addition to placing in the ordinary pasteboard case, before taking out of doors in a low temperature.

Some musicians may advise leaving the wiper in the bore of the instrument when not in use, but this is without doubt a bad practice, as the wiper is often damp and liable to cause a swelling of the instrument which is very likely to result in a split or two.

The springs, screws and other bearings should be kept lightly oiled, which can be done very easily with a camel's hair brush. The rings, keys and ferrules may be easily kept bright by occasionally rubbing with a piece of dry chamois skin or flannel.

COUESNON & CIE., PARIS, CLARINETS



Couesnon & Cie. Clarinet Factory at Garennes, France

We have recently been appointed Sole Western United States Agents for the celebrated Couesnon & Cie. Clarinets, Brass Band Instruments, Saxophones, etc.

HISTORICAL SKETCH OF THE HOUSE OF COUESNON & CIE. AND A FEW VITAL FACTS RELATIVE TO THEIR INSTRUMENTS

Couesnon & Cie. have been manufacturing Brass and Wood Wind Instruments for about ninety years. The beginning was in a factory established in 1827 by Monsieur Guichard, who sold out his interests to Monsieur Gautrot in 1845. Under the name of Gautrot & Cie. the firm flourished for many years and the revolutionizing inventions by Gautrot, among which we mention only the most important ones, viz: "Systeme Transpositeur" (Transposition System), "Perce Compensatrice" (Compensating Pistons), and the celebrated "Sarrusophones," were responsible in no small degree for the continuously increasing reputation of the firm.

In 1850, the house of Tulou, manufacturers of Flutes and Clarinets, was consolidated with Gautrot & Cie., and in 1880 the world-famous Triebert, maker of Oboes, English Horns, and Bassoons, became associated with the concern.

Since 1882 Monsieur A. Couesnon, who succeeded Monsieur Gautrot, has been the active head of the firm, which was changed to "Couesnon & Cie." in that year.

Under his able management they have unquestionably become the largest manufacturers of Band Instruments in the world, their factories at the present time employing nearly 1,000 workmen. The main factory at Chateau Thierry turns out approximately 50,000 Brass Instruments per annum, which alone is more than the combined output of all other French manufacturers. At Garennes they manufacture nearly 10,000 Clarinets a year. All the parts of their products, even the smallest, are made in their own establishments; no finished or unfinished parts are bought and then assembled as is the practice of many German and Austrian manufacturers.

Their system of manufacturing was entirely changed about three years ago, when Monsieur A. Couesnon made a trip through the United States, visiting every dealer and jobber of consequence and making an exhaustive study of American methods of manufacture. As a result of this trip, through the courtesy of the foremost American makers, it has become possible, through the adoption of every modern time and labor saving device, to cut down their costs of production to a minimum. While this was only accomplished after the expenditure of a quarter of a million francs on improvements and machinery, they now have a **MODEL AMERICAN PLANT** for the manufacture of Band Instruments **IN FRANCE**.

Their advertising expense is very small; labor is considerably cheaper in France than in the United States; their process of manufacture is highly efficient and most economical: in consequence, they are able to produce and sell their instruments, quality for quality, not only much more cheaply than American makers, but for far less than other European makers.

The "American Perfection" line, built exclusively after up-to-date and most approved American models, although sold at one-half the price of domestic makes, will compare most favorably with the instruments of many American manufacturers, and is surpassed by only a few of the foremost makes.

The distinctions which Couesnon & Cie. have received at the various Expositions, including seven gold medals and the verdict of the Jury of Awards at the Paris Exposition of 1900, placing their instruments "Hors Concour," meaning "Beyond Competition," are the strongest proofs that **COUESNON & CIE. KNOW HOW TO MAKE BAND INSTRUMENTS THAT ARE RIGHT.**

COUESNON & CIE., PARIS, CLARINETS

THE MAKE USED BY ALL FRENCH ARMY AND NAVY MUSICIANS

Grenadilla, Fine Oil Finish, German Silver Keys, Cork Joints. Each Instrument furnished with Mouthpiece, Nickel-plated Mouthpiece Cap, Reed Holder and Reed

KEYS OF A, B_b, C AND E_b

"20th CENTURY"

"AMERICAN PERFECTION"



Nos. R90—R90½ Nos. R91—R91½ Nos. R92—R92½ No. R191½ No. R192½ No. R193½ No. R194½

Couesnon Clarinets sent anywhere on three days trial. Easy Monthly Payments. See following page for descriptions and prices.

COUESNON & CIE., PARIS, CLARINETS

20th CENTURY—STANDARD GRADE

THE MAKE USED BY ALL FRENCH ARMY AND NAVY MUSICIANS

Grenadilla, Fine Oil Finish, German Silver Keys, Cork Joints. Each Instrument furnished with Mouthpiece, Nickel-plated Mouthpiece Cap, Reed Holder and Reed

13 KEYS AND 2 RINGS

High Pitch	Each	Low Pitch	Each
No. R90A Key of A, grenadilla, 13 German silver keys, 2 rings, German silver trimmed, Albert system and trill keys. Fine finish and workmanship.....	\$18.00	No. R90 $\frac{1}{2}$ A Key of A, grenadilla, 13 German silver keys, 2 rings, German silver trimmed, Albert system and trill keys. Fine finish and workmanship.....	\$18.00
R90B—Key of B \flat , same as No. R90A.....	18.00	R90 $\frac{1}{2}$ B—Key of B \flat , same as No. R90 $\frac{1}{2}$ A.....	18.00
R90C—Key of C, same as No. R90A.....	18.00	R90 $\frac{1}{2}$ C Key of C, same as No. R90 $\frac{1}{2}$ A.....	18.00
R90E—Key of E \flat , same as No. R90A.....	18.00	R90 $\frac{1}{2}$ E Key of E \flat , same as No. R90 $\frac{1}{2}$ A.....	18.00

15 KEYS AND 2 RINGS

High Pitch	Each	Low Pitch	Each
No. R91A Key of A, grenadilla, 15 German silver keys, 2 rings, German silver trimmed, Albert system with double C sharp key to trill B natural to C sharp, and C sharp to D sharp. Fine finish and workmanship.....	\$22.00	No. R91 $\frac{1}{2}$ A—Key of A, grenadilla, 15 German silver keys, 2 rings, German silver trimmed, Albert system with double C sharp key to trill B natural to C sharp, and C sharp to D sharp. Fine finish and workmanship.....	\$22.00
R91B—Key of B \flat , same as No. R91A.....	22.00	R91 $\frac{1}{2}$ B Key of B \flat , same as No. R91 $\frac{1}{2}$ A.....	22.00
R91C Key of C, same as No. R91A.....	22.00	R91 $\frac{1}{2}$ C Key of C, same as No. R91 $\frac{1}{2}$ A.....	22.00
R91E—Key of E \flat , same as No. R91A.....	22.00	R91 $\frac{1}{2}$ E—Key of E \flat , same as No. R91 $\frac{1}{2}$ A.....	22.00

15 KEYS, 4 RINGS AND 4 ROLLERS

High Pitch	Each	Low Pitch	Each
No. R92A—Key of A, grenadilla, 15 German silver keys, 4 rings, with trill keys C and B, and E \flat key for trilling F sharp and C sharp, with rubber roller keys for the little finger of both hands. Fine finish and workmanship.....	\$27.50	No. R92 $\frac{1}{2}$ A Key of A, grenadilla, 15 German silver keys, 4 rings, with trill keys C and B, an E \flat key for trilling F sharp and C sharp, with rubber roller keys for the little finger of both hands. Fine finish and workmanship.....	\$27.50
R92B—Key of B \flat , same as No. R92A.....	27.50	R92 $\frac{1}{2}$ B—Key of B \flat , same as No. R92 $\frac{1}{2}$ A.....	27.50
R92C—Key of C, same as No. R92A.....	27.50	R92 $\frac{1}{2}$ C Key of C, same as No. R92 $\frac{1}{2}$ A.....	27.50
R92E—Key of E \flat , same as No. R92A.....	27.50	R92 $\frac{1}{2}$ E—Key of E \flat , same as No. R92 $\frac{1}{2}$ A.....	27.50

High Grade
Correctly Tuned

"AMERICAN PERFECTION" SUPERIOR GRADE

Beautifully Made
Perfect in Pitch

The following Clarinets are made of the finest selected material, the mechanism is of superior construction and most accurately adjusted, highest class workmanship throughout. They are handsomely finished and highly polished. Tone quality beautiful, intonation guaranteed perfect. High-grade instruments in every particular. For the use of artists and professional players.

15 KEYS AND 2 RINGS

Low Pitch Only

No.	Each
R191 $\frac{1}{2}$ A—Key of A, finest selected grenadilla, Mozambique ebony bell, hard rubber mouthpiece, 15 German silver keys, 2 rings, German silver trimmed, cork joints. Albert system with double C sharp key to trill B natural to C sharp, and C sharp to D sharp. Mouthpiece cap included.....	\$30.00
R191 $\frac{1}{2}$ B Key of B \flat , same as No. R191 $\frac{1}{2}$ A.....	30.00
R191 $\frac{1}{2}$ C Key of C, same as No. R191 $\frac{1}{2}$ A.....	30.00
R191 $\frac{1}{2}$ E—Key of E \flat , same as No. R191 $\frac{1}{2}$ A.....	30.00

15 KEYS, 4 RINGS AND 4 ROLLERS

Low Pitch Only

No.	Each
R192 $\frac{1}{2}$ A—Key of A, finest selected grenadilla, Mozambique ebony bell, hard rubber mouthpiece, 15 German silver keys, 4 rings, with trill keys C and B, an E \flat key for trilling F sharp and C sharp, with hard rubber roller keys for the little finger of both hands. German silver trimmed, cork joints. Mouthpiece cap included.....	\$35.00
R192 $\frac{1}{2}$ B—Key of B \flat , same as No. R192 $\frac{1}{2}$ A.....	35.00
R192 $\frac{1}{2}$ C—Key of C, same as No. R192 $\frac{1}{2}$ A.....	35.00
R192 $\frac{1}{2}$ E—Key of E \flat , same as No. R192 $\frac{1}{2}$ A.....	35.00

BOEHM SYSTEM

17 KEYS AND 6 RINGS

Low Pitch Only

No.	Each
R193 $\frac{1}{2}$ A—Key of A, finest selected grenadilla, hard rubber mouthpiece, 17 German silver keys, 6 rings, Full Boehm system, German silver trimmed, cork joints, finest workmanship and finish. Mouthpiece cap included.....	\$50.00
R193 $\frac{1}{2}$ B—Key of B \flat , same as No. R193 $\frac{1}{2}$ A.....	50.00
R193 $\frac{1}{2}$ C—Key of C, same as No. R193 $\frac{1}{2}$ A.....	50.00
R193 $\frac{1}{2}$ E Key of E \flat , same as No. R193 $\frac{1}{2}$ A.....	50.00

17 KEYS AND 7 RINGS

Low Pitch Only

No.	Each
R194 $\frac{1}{2}$ A—Key of A, finest selected grenadilla, hard rubber mouthpiece, 17 German silver keys, 7 rings, extra padded ring for forked E \flat -B \flat , raised finger holes, Full Boehm system, German silver trimmed, cork joints, finest workmanship and finish. Mouthpiece cap included.....	\$60.00
R194 $\frac{1}{2}$ B—Key of B \flat , same as No. R194 $\frac{1}{2}$ A.....	60.00
R194 $\frac{1}{2}$ C—Key of C, same as No. R194 $\frac{1}{2}$ A.....	60.00
R194 $\frac{1}{2}$ E—Key of E \flat , same as No. R194 $\frac{1}{2}$ A.....	60.00

See page 6 for shipping weights.

BUFFET, CRAMPON & CO., PARIS, CLARINETS

(EVETTE & SCHAEFFER, SUCCESSORS)

Each Clarinet is furnished with a Morocco Bag, two Wood Mouthpieces, Mouthpiece Cap and Swab. Nos. R19½ and R20½ are also supplied with a German Silver Music Rack

EITHER HIGH OR LOW PITCH

(Except Boehm System, which can be supplied only in LOW PITCH)



Nos. R13—R13½



Nos. R14—R14½



Nos. R15—R15½



Nos. R17—R17½



No. R19½



No. R20½

ORDINARY SYSTEM

BOEHM SYSTEM

SHERMAN, CLAY & CO'S

Own System Clarinet, Manufactured Especially for Us by

BUFFET, CRAMPON & CO., PARIS

EITHER HIGH OR LOW PITCH

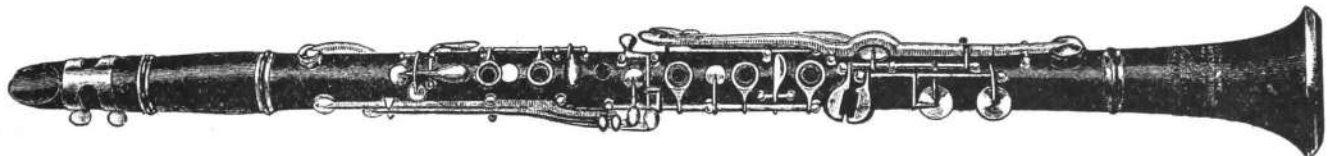

Nos. R18—R18½

See following page for descriptions and prices

All Buffet Clarinets are furnished in Oil Finish—no lacquer or polish to hide defects in the wood. The two wood mouthpieces can be exchanged for one of hard rubber at an additional net charge of \$1.25. Three days' free trial on all Buffet Clarinets.

BUFFET, CRAMPON & CO., PARIS, CLARINETS

(EVETTE & SCHAEFFER, SUCCESSORS)

Each Clarinet is furnished with a Morocco Bag, two Mouthpieces, Mouthpiece Cap and Swab. Nos. R19½ and R20½ are also supplied with a German Silver Music Rack

EITHER HIGH OR LOW PITCH

(Except Boehm System, which can be supplied only in LOW PITCH)

ORDINARY SYSTEM

15 KEYS AND 2 RINGS

No.	High Pitch	Each	No.	Low Pitch	Each
R13A	Key of A, grenadilla wood, 15 German silver keys, 2 rings, with trill keys C sharp and B \flat	\$38.50	R13½A	Key of A, grenadilla wood, 15 German silver keys, 2 rings, with trill keys C sharp and B \flat	\$38.50
R13B	Key of B \flat , same as R13A.....	38.50	R13½B	Key of B \flat , same as R13½A.....	38.50
R13C	Key of C, same as R13A.....	38.50	R13½C	Key of C, same as R13½A.....	38.50
R13E	Key of E \flat , same as R13A.....	38.50	R13½E	Key of E \flat , same as R13½A.....	38.50

15 KEYS, 2 RINGS AND 4 ROLLERS

(The same Clarinet as Nos. R13—R13½, but with hard rubber rollers on keys for little finger of both hands)

No.	High Pitch	Each	No.	Low Pitch	Each
R14A	Key of A, grenadilla wood, 15 German silver keys, 2 rings with trill keys C sharp and B \flat , with rubber roller keys for little finger of both hands.....	\$44.50	R14½A	Key of A, grenadilla wood, 15 German silver keys, 2 rings, with trill keys C sharp and B \flat , with rubber roller keys for little finger of both hands.....	\$44.50
R14B	Key of B \flat , same as R14A.....	44.50	R14½B	Key of B \flat , same as R14½A.....	44.50
R14C	Key of C, same as R14A.....	44.50	R14½C	Key of C, same as R14½A.....	44.50
R14E	Key of E \flat , same as R14A.....	44.50	R14½E	Key of E \flat , same as R14½A.....	44.50

15 KEYS, 4 RINGS AND 4 ROLLERS

No.	High Pitch	Each	No.	Low Pitch	Each
R15A	Key of A, grenadilla wood, 15 German silver keys, 4 rings, with trill keys C and B, an E \flat key for trilling F sharp and C sharp, with rubber roller keys for the little finger of both hands.....	\$48.50	R15½A	Key of A, grenadilla wood, 15 German silver keys, 4 rings, with trill keys C and B, an E \flat key for trilling F sharp and C sharp, with rubber roller keys for the little finger of both hands.....	\$48.50
R15B	Key of B \flat , same as R15A.....	48.50	R15½B	Key of B \flat , same as R15½A.....	48.50
R15C	Key of C, same as R15A.....	48.50	R15½C	Key of C, same as R15½A.....	48.50
R15E	Key of E \flat , same as R15A.....	48.50	R15½E	Key of E \flat , same as R15½A.....	48.50

16 KEYS, 4 RINGS AND 4 ROLLERS

No.	High Pitch	Each	No.	Low Pitch	Each
R17A	Grenadilla wood, 16 German silver keys, 4 rings, with trill keys C sharp and B \flat , an E \flat key for trilling F sharp and C sharp, same as on No. R15 with additional C sharp and G sharp trilling key with first finger of the right hand and double E \flat key for the little finger of the left hand, with rubber roller keys for the little finger of both hands.....	\$55.00	R17½A	Grenadilla wood, 16 German silver keys, 4 rings with trill keys C sharp and B \flat , an E \flat key for trilling F sharp and C sharp, same as on No. R15, with additional C sharp and G sharp trilling key with first finger of the right hand and double E \flat key for the little finger of the left hand, with rubber roller keys for the little finger of both hands.....	\$55.00
R17B	Key of B \flat , same as R17A.....	55.00	R17½B	Key of B \flat , same as R17½A.....	55.00
R17C	Key of C, same as R17A.....	55.00	R17½C	Key of C, same as R17½A.....	55.00
R17E	Key of E \flat , same as R17A.....	55.00	R17½E	Key of E \flat , same as R17½A.....	55.00

BOEHM SYSTEM

17 KEYS, 6 RINGS

No.	Low Pitch Only	Each
R19½A	Key of A, grenadilla wood, 17 German silver keys, 6 rings, Full Boehm system.....	\$75.00
R19½B	Key of B \flat , same as R19½A.....	75.00
R19½C	Key of C, same as R19½A.....	75.00
R19½E	Key of E \flat , same as R19½A.....	75.00

20 KEYS, 7 RINGS

No.	Low Pitch Only	Each
R20½A	Key of A, grenadilla wood, 20 German silver keys, 7 rings, Evette & Schaeffer patent, with additional articulated G sharp and C sharp key to trill from B natural to C sharp with first finger of right hand, and a double E \flat key for little finger of left hand, also an extra key to descend to low E \flat	\$100.00
R20½B	Key of B \flat , same as R20½A.....	100.00
R20½C	Key of C, same as R20½A.....	100.00
R20½E	Key of E \flat , same as R20½A.....	100.00

SHERMAN, CLAY & CO.'S

Own System Clarinet, Manufactured Especially for Us by

BUFFET, CRAMPON & CO., PARIS

EITHER HIGH OR LOW PITCH

This Half-Boehm System Clarinet is made for those players who have learned upon the old 15-keyed system and do not feel like spending months of practice to perfect themselves upon the Boehm system.

Practically all that is accomplished upon the Boehm system can be done upon this new Clarinet by any player of the old system without any change of fingering.

This will prove a boon to all Clarinet players using the old system.

In addition to the 15-keyed system, we have added a new articulated G sharp and C sharp key whereby you can trill from B natural to C sharp, and from F sharp to G sharp, with first finger of the right hand, a double E flat key for the little finger of the left hand, also a B flat shake key on the upper joint to shake from B flat to B natural.

No.	High Pitch	Each	No.	Low Pitch	Each
R18A	Key of A, grenadilla wood, 17 German silver keys, 5 rings with rollers for the little finger of both hands.....	\$65.00	R18½A	Key of A, grenadilla wood, 17 German silver keys, 5 rings with rollers for the little finger of both hands.....	\$65.00
R18B	Key of B \flat , same as R18A.....	65.00	R18½B	Key of B \flat , same as R18½A.....	65.00
R18C	Key of C, same as R18A.....	65.00	R18½C	Key of C, same as R18½A.....	65.00
R18E	Key of E \flat , same as R18A.....	65.00	R18½E	Key of E \flat , same as R18½A.....	65.00

CLARINET CASES AND FURNISHINGS



Nos. R0-R3



No. R5—For Two Clarinets
No. R4—For Three Clarinets

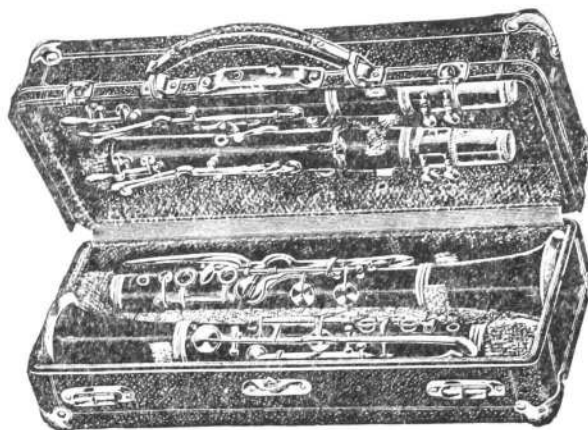

No. R10—For One Clarinet
No. R40—For Two Clarinets
No. R50—For Three Clarinets

No.	Each
R0—Heavy smooth sole leather, hand sewed, fleeced flannel lined, leather handle; also loop to attach to belt for A Clarinet.....	\$1.50
R1—Same as No. R0, for B \flat Clarinet.....	1.50
R2—Same as No. R0, for C Clarinet.....	1.50
R3—Same as No. R0, for E \flat Clarinet.....	1.50
R5—Wood Case, covered with smooth leather, fleeced flannel lined, iron valence, covered with leather around fronts and ends; inside lock, nickel trimmings, fine handle, for Two Clarinets	4.00
R4—Same as No. R5, for Three Clarinets.....	4.50

No.	Each
R10—The finest Clarinet Case manufactured. Genuine seal grain cowhide leather, lined with silk plush; very substantial; nickel-plated brass trimmings—will not rust. The instruments are held securely by spring clutches and plugs and all points of contact are padded, so that marring of the finish or bending of the keys is impossible. For One Clarinet.....	\$6.50
R40—Same as No. R10, for Two Clarinets.....	7.00
R50—Same as No. R10, for Three Clarinets.....	7.50

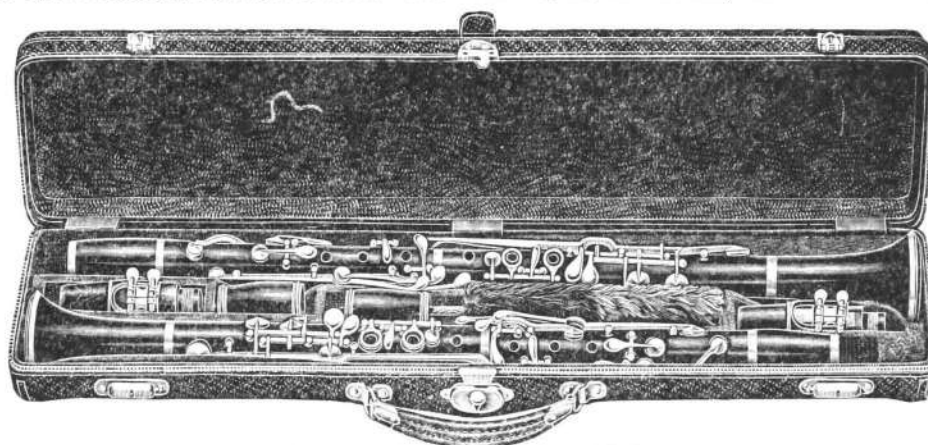

No. R6—For Two Single Piece Clarinets
No. R7—For Three Single Piece Clarinets

No.	Each
R6—Leather Board Shell, covered with black rudge, finished in black shellac, making it strictly waterproof and more durable than leather; iron valence covered with rudge all around the Case; lined with fleece flannel, nickel plated lock, hinges and catches; fitted for two Clarinets, A and B \flat , either High or Low Pitch, in one piece or joints. An elegant Case, especially light, compact and strong.....	\$7.50
R7—Same as No. R6, but for Three One-Piece Clarinets.....	8.00

MOUTHPIECES Without Reed Holder

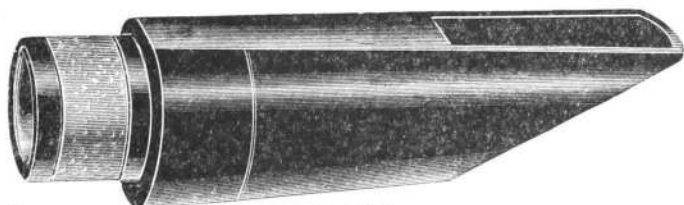

No. R20

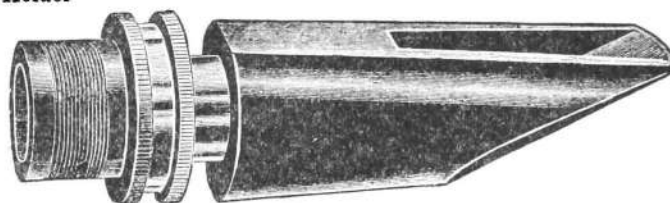

No. R27

No.	Each
R20—Ebony or cocoa, fine French; cork joint, for A, B \flat or C.....	\$0.50
R21—Ebony or cocoa, fine French; cork joint, for E \flat50
R25—Ebony or grenadilla, Buffet-Crampon; cork joint, for A, B \flat or C.....	1.75
R26—Ebony or grenadilla, Buffet-Crampon; cork joint, for E \flat	1.75
R28—Ebonite (rubber), fine quality, cork joint, for A, B \flat or C.....	1.75
R27—Ebony or grenadilla, with screw tuning slide, cork joint, for A, B \flat or C.....	2.25
R29—Ebonite (rubber), genuine Buffet, Finest Quality Artist's, cork joint, for A, B \flat or C.....	4.50
R30—Ebonite (rubber), genuine Buffet, Finest Quality Artist's, cork joint, for E \flat	4.50
R31—Crystal, genuine Buffet, finest, with cork joint, for A, B \flat or C.....	5.00

Postage: All of the above Mouthpieces take the 1-lb. rate by Parcel Post.

See page 6 for shipping weights of Clarinet Cases.

CLARINET FURNISHINGS

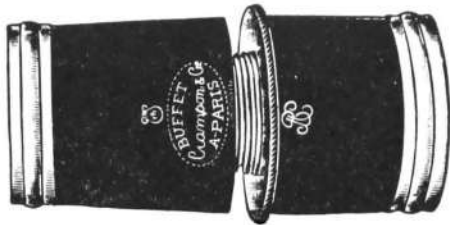

No. R37

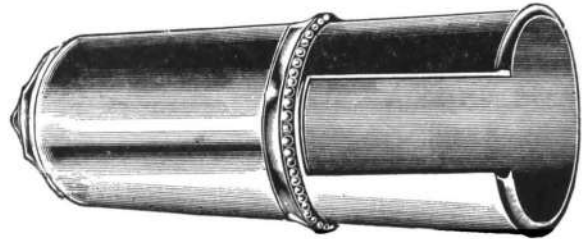

Nos. R35-R35¹/₂

MOUTHPIECE CAPS

No.	Each	Postage
R35—Aluminum, for A, B _b or C mouthpieces.....	\$0.25	2 cts.
R35 ¹ / ₂ —Aluminum, for E _b mouthpieces.....	.25	2 cts.

TUNING BARRELS

No.	Each	Postage
R37—Grenadilla, with extension screw slide and German silver rings; genuine Buffet make.....	\$4.00	1-lb. rate

PADS

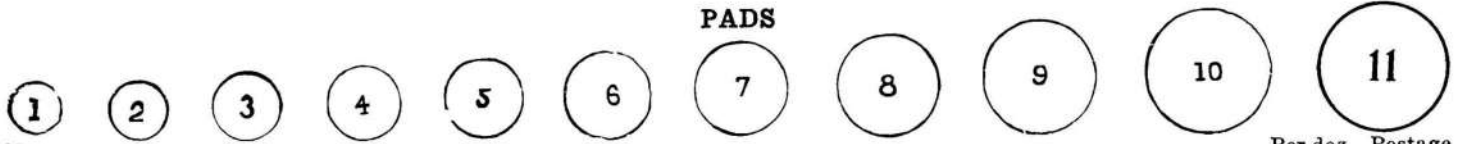

No.	Per doz.	Postage
R16—Bladder covered, sizes illustrated above.....	\$0.20	1 ct.
R17—Kid covered, sizes illustrated above.....	.20	1 ct.



Nos. R60-R60¹/₂

MUSIC RACKS



No. R5

No.	Each	Postage
R60—Nickel plated, adjustable screw band, for A, B _b or C Clarinet.....	\$0.75	4 cts.
R60 ¹ / ₂ —Nickel plated, adjustable screw band, for E _b Clarinet.....	.75	4 cts.
R 5—Nickel plated, Victor Patent, fits any Clarinet.....	.75	4 cts.

REEDS

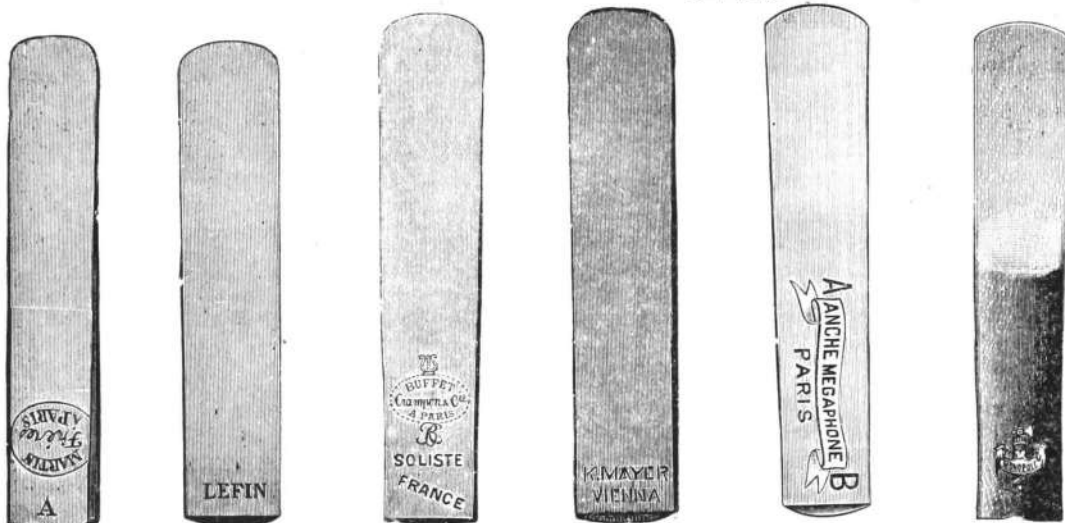

No. R17 No. R14 No. R19 No. R18 No. R20 No. R21



No. R22

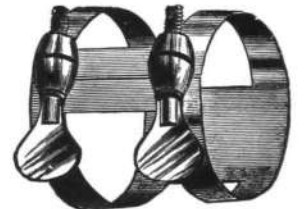

Nos. R26-R27

No.	Each	Per doz.	Postage per doz.
R 9—French, good quality, A, B _b , C and E _b	\$0.05	\$0.50	2 cts.
R17—French, Martin, A, B _b , C and E _b10	.90	2 cts.
R14—French, Le Fin, A, B _b , C and E _b10	1.00	2 cts.
R16—French, Fournier, A, B _b , C and E _b15	1.40	2 cts.
R21—French, Couesnon & Cie., "Monopole," A, B _b , C and E _b15	1.50	2 cts.
R19—French, Buffet, A, B _b , C, and E _b , stamped Soliste.....	.15	1.50	2 cts.
R20—French, Megaphone, A, B _b , C and E _b15	1.55	2 cts.
R15—French, Kroll, A, B _b , C and E _b , waterproof, red or yellow stripe.....	.15	1.65	2 cts.
R18—K. Meyer, A, B _b , C and E _b , genuine Vienna Reeds.....	.20	1.90	2 cts.
R22—Super-o-phone, sterilized and waterproof, finest French make, each Reed in individual envelope. Put up in neat enameled metal boxes containing one dozen Reeds, for A, B _b and C, or E _b Clarinet.....		2.50	2 cts.

REED HOLDERS

No.	Each	Postage
R26—German silver, adjustable screws, for A, B _b or C mouthpieces.....	\$0.25	1 ct.
R27—German silver, adjustable screws, for D or E _b mouthpieces.....	.25	1 ct.

CLARINET FURNISHINGS

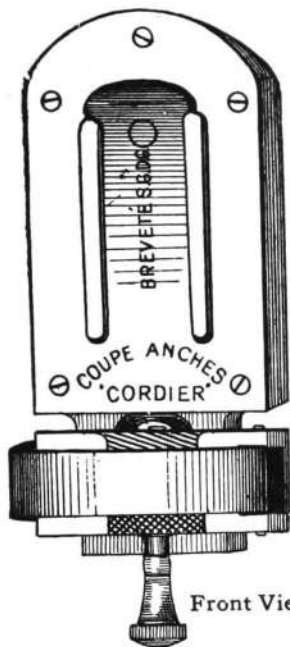

Front View



No. R1

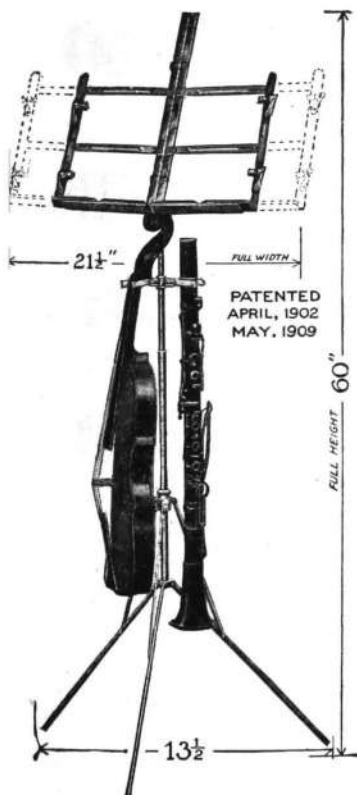

Mills Clarinet Holder In Use

REED TRIMMER

No. **R12**—A simple contrivance with which the Reed is trimmed perfectly true and even. The reed is placed upon a sliding bed and adjusted to the proper distance to be cut off, a stationary button on the reverse side is pressed and the job is done in a clean and accurate manner. \$4.00 4 cts.

KEY ADJUSTER AND OILER



KEY ADJUSTER AND OILER FOR WOOD WIND INSTRUMENTS

No. **R11**—Lake Key Adjuster and Oiler. Best quality hard rubber, with cap protector and gold ferrule. Screwdriver of best tool steel, spiral oil feed. A very handy combination tool for all wood wind instrument players \$1.25 2 cts.

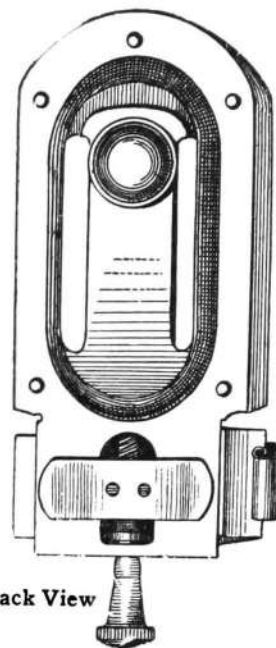

Back View

REED CASES

No. **R1**—Solid leather, pocketbook style, glass reed holder. \$0.40 3 cts.
 No. **R3**—Leather covered wood box, plush lined, nickel catch, with glass compartment holding 6 Reeds.60 4 cts.



No. R3

MILLS PERFECT CLARINET HOLDER

A boon to violin, mandolin, flute, oboe, clarinet and cornet players; holds the instrument entirely free from floor. Does not interfere with the adjustment of the music stand. Will not wear out. Remains on your music stand and folds up with it, occupying no extra space.

Its construction is simple and easily understood, but it performs its functions to the entire satisfaction of the most critical user. The holder fits around the upper tube or rod of any ordinary music stand, resting upon the next rod or tube, and turning freely in any or all directions. The spring clutches will adjust to various size bores of instruments and are made of the best phosphor bronze, covered with rubber, absolutely protecting the instrument from any injury.

No. **R7**—Mills Perfect Clarinet Holder. \$1.00 4 cts.



Mills Clarinet Holder, No. R7
One-third actual size

SWABS

No. **R 2**—Worsted, variegated colors, thick, full body; covered wire handle. \$0.15 2 cts.
 No. **R 4**—Silk, variegated colors, thick, full body; covered wire handle.25 2 cts.
 No. **R 7**—Worsted, variegated colors, double swab, an end for oiling and one for drying.40 4 cts.
 No. **R10**—Silk, variegated colors, wood handle, with screwdriver75 4 cts.



Nos. R2—R4



No. R10

SPRINGS

No. **R41**—Steel Springs, complete set. \$0.60 1 ct.

OBOES—BUFFET, CRAMPON & CO.

HIGH OR LOW PITCH

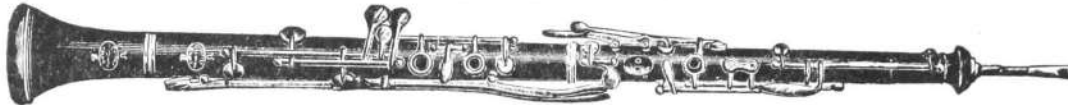

Nos. R3—R3¹/₂

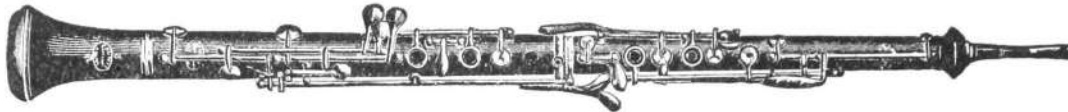

Nos. R5—R5¹/₂

No.		Each
R3	—Grenadilla wood, 15 German silver keys, 3 rings for F sharp, with extra C sharp key, High Pitch	\$40.00
R3 ¹ / ₂	—Same description as No. R3, but Low Pitch	40.00
R5	—Grenadilla wood, 17 German silver keys, 4 rings for F sharp, with extra thumb mechanism for B _b and C natural, with E _b key for facilitating the passing from low C to E _b with the little finger of the right hand. (Model Militaire.) High Pitch	75.00
R5 ¹ / ₂	—Same description as No. R5, but Low Pitch	75.00

OBOE REEDS



No.	Each	Postage	No.	Each	Postage
R2	—French, good quality.....	\$0.50	R6	—Buffet, Crampon & Co., cork joint.....	\$0.85
R5	—Buffet, Crampon & Co., silk-wrapped joint..	.75	R4	—Karl Meyer, Vienna Conservatory, superior quality	1.50

FLUTES

IN C (KNOWN AS D) WITH GERMAN SILVER KEYS AND RINGS. IN PASTEBOARD BOXES



No. R106. 1 Key

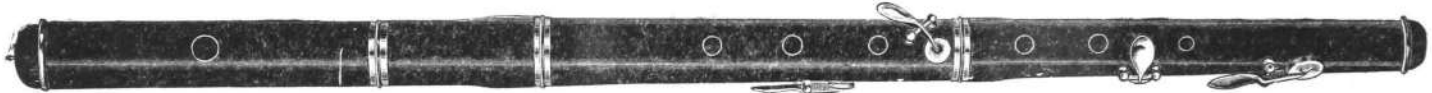

No. R109. 4 Keys



No. R111. 6 Keys

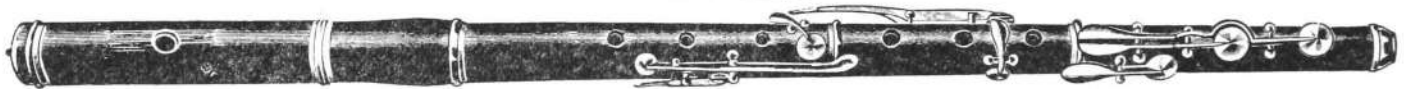

Nos. R116—R116¹/₂. 8 Keys



No. R122. 10 Keys



Nos. R317—R317¹/₂. 10 Keys

No.	Each	No.	Each
R106	—Grenadilla, 1 key, High Pitch	R116 ¹ / ₂	—Grenadilla, 8 keys, with tuning slide, cork joints, Low Pitch
R107	—Grenadilla, 1 key, with tuning slide, High Pitch ...		
R109	—Grenadilla, 4 keys, with tuning slide, High Pitch ...	R122	—Grenadilla, 10 keys, with tuning slide, cork joints, High Pitch
R111	—Grenadilla, 6 keys, with tuning slide, cork joints, High Pitch		
R116	—Grenadilla, 8 keys, with tuning slide, cork joints, High Pitch	R317	—Grenadilla, 10 keys, with tuning slide, cork joints, Meyer pattern, High Pitch
		R317 ¹ / ₂	—Grenadilla, 10 keys, with tuning slide, cork joints, Meyer pattern, Low Pitch

See page 6 for shipping weights.

"NACH MEYER" (Meyer Pattern) CONCERT FLUTES—Finest Imported

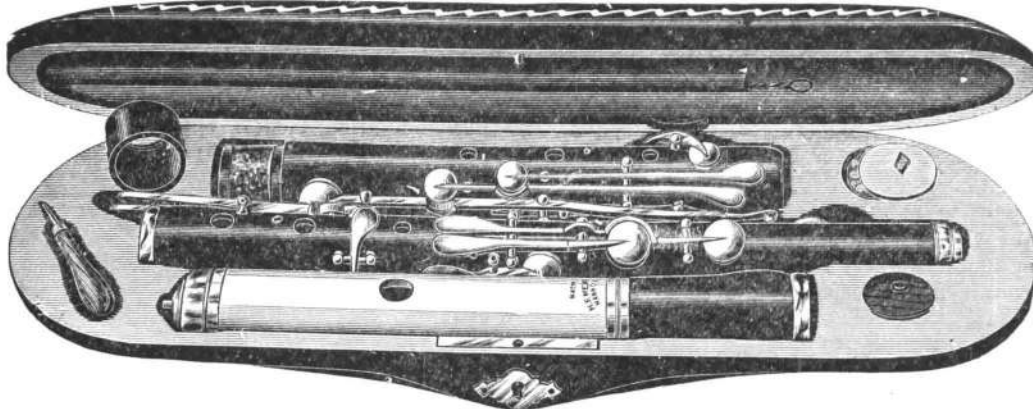

These Meyer Pattern Flutes are made for us by the most reliable and skilled makers of Germany. Although comparatively inexpensive, they represent the greatest value artistically and commercially ever offered. They are correct in intonation, respond easily, and are mechanically far above flutes offered elsewhere at similar prices.

KEY OF C (KNOWN AS D)

IVORY HEAD, GRENADILLA WOOD, GERMAN SILVER KEYS, RINGS AND CAPS

Each in handsome case, with joint covers, screwdriver, grease box and pads.

No.		Each
R216	—Grenadilla, 8 keys, ivory head, tuning slide, cork joints, High Pitch	\$17.50
R222	—Grenadilla, 10 keys, ivory head, tuning slide, cork joints, extra quality, High Pitch	20.00
R318	—Grenadilla, 11 keys, ivory head, tuning slide, cork joints, extra quality, Meyer pattern, High Pitch	22.50
R326	—Grenadilla, 13 keys, ivory head, tuning slide, cork joints, extra quality, Meyer pattern, High Pitch	25.00
R326½	—Grenadilla, 13 keys, ivory head, tuning slide, cork joints, extra quality, Meyer pattern, Low Pitch	25.00

CYLINDER BORE FLUTE BY GEORGE CLOOS
(American Manufacture)

This Flute has cylindrical bore and finger-holes covered with keys. In appearance it resembles a Boehm Flute, but the fingering is the same as the ordinary or Meyer Flute.

No.		Each
R9½	—Grenadilla, key of D, German silver keys and trimmings, in elegant case, Low Pitch	\$60.00

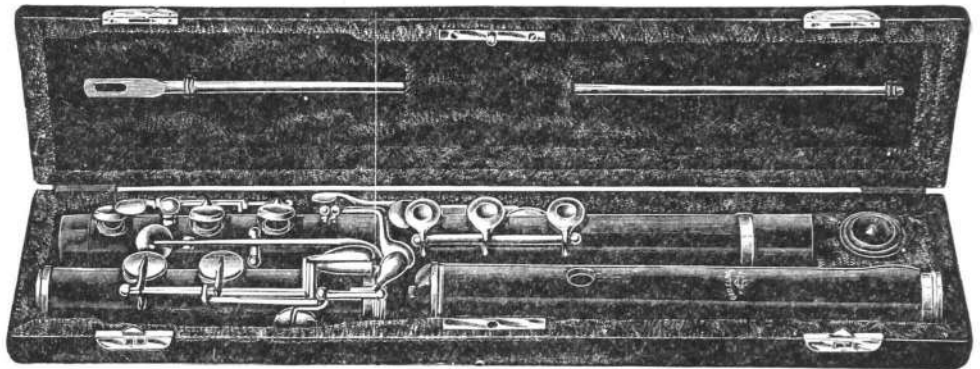

No. R9½

BOEHM SYSTEM FLUTES
CARL RICHTER

In this Flute we offer an instrument made with the same care and precision that is evidenced in the highest-priced Flutes on the market, and for the use of the serious amateur or semi-professional player we can thoroughly recommend it as an instrument that will give complete satisfaction. Finished workmanship is evidenced in every detail of its construction, the intonation is perfect, the tone quality excellent.

No.		Each
R4½	—Grenadilla, Full Boehm system, German silver keys to C, cylinder bore, closed G sharp key, in plush-lined, leather-covered case, Low Pitch	\$75.00

COUESNON & CIE., PARIS

An excellent Flute, used by the soloist of the world-famous "Garde Republicaine" Band and by all French army and navy flutists.
LOW PITCH

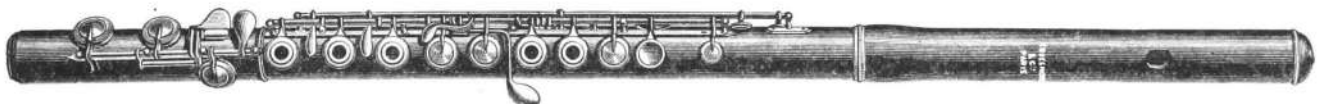

No.		Each
R6½	—Grenadilla, German silver keys to C, cylinder bore, closed G sharp key, in velvet or chamois lined leather case, Low Pitch	\$85.00

BUFFET, CRAMPON & CO., PARIS
HIGH OR LOW PITCH

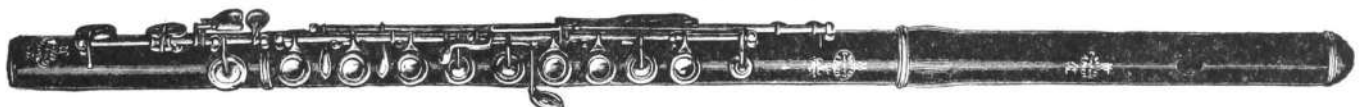

No.		Each
R12	—Grenadilla, German silver keys to C, cylinder bore, closed G sharp key, in fine velvet-lined case, including swab, screw-driver, etc., High Pitch	\$100.00
R12½	—Same as No. R12, but Low Pitch	100.00

Three days trial allowed on all Boehm System Flutes. Sold on Easy Monthly Payments.

BOEHM FLUTES

EMIL RITTERSHAUSEN, BERLIN

LOW PITCH

Emil Rittershausen's Flutes are endorsed by the greatest authorities of Europe and America for their excellence and practical improvements, also for their skillful construction, resulting in absolute perfection. The new proportion adopted by him materially aids in the production of a rich, clear and sonorous tone of remarkable brilliancy and vibratory quality without the least exertion to the performer.

The Rittershausen Flutes can furthermore be recommended for the marvelous exactness of their delicate yet extremely durable mechanism, having invariably secured the highest honors wherever exhibited.

Their American successes were at the Chicago World's Fair, 1893, and the Louisiana Purchase Exposition at St Louis, 1904, where they were awarded a gold medal for their vast superiority over all competitors.



No.	Each
R7½—Grenadilla, German silver keys to C, cylindrical bore, closed G sharp key, in elegant velvet-lined morocco case, including swab, screwdriver, etc., Low Pitch	\$117.50
R8½—Same, but with pure silver keys and mountings, Low Pitch	165.00

FLUTE CASES

No.	Each
R330—Leather Covered Wood Case, velvet lined, lock; for 8-key flute	\$2.75
R331—Leather Covered Wood Case, velvet lined, lock; for 10- or 11-key flute	3.00
R332—Leather Covered Wood Case, velvet lined, lock; for 13-key flute	3.25
R333—Leather Covered Wood Case, velvet or chamois lined, for Boehm flute	4.00



Nos. R330—R332

FLUTE FURNISHINGS

FLUTE MOUTHPIECES

No.	Each	Postage
R1—Britannia, adjustable, with regulating screw	\$0.15	3 cts.

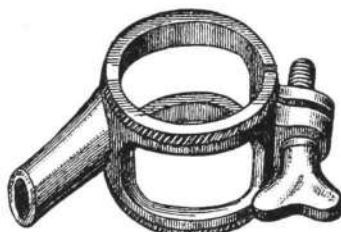

Flute Mouthpiece—No. R1

FLUTE PADS

For sizes, see Clarinet Pads, page 66.

No.	Per doz.	Postage
R2—Bladder covered	\$0.20	1 ct.
R3—Kid covered20	1 ct.
R4—Kid covered, without holes, for Boehm Flutes, sold only in sets	Per set, 1.50	1 ct.
R5—Kid covered, with holes, for Boehm Flutes, sold only in sets	Per set, 1.50	1 ct.

FLUTE SCREWDRIVER

No.	Each	Postage
R9—Grenadilla handle, small	\$0.15	2 cts.

(See also Lake Key Adjuster and Oiler, page 67.)

FLUTE SWABS

(See illustrations, Clarinet Swabs, page 67.)

No.	Each	Postage
R 2—Worsted, variegated colors, full body, covered wire handle	\$0.15	2 cts.
R 4—Silk, variegated colors, full body, covered wire handle25	2 cts.
R 7—Silk, variegated colors, double swab, end for oiling and drying40	4 cts.
R10—Silk, variegated colors, wood handle, with screwdriver75	4 cts.

PICCOLOS

IN C (KNOWN AS D) FOR ORCHESTRA; D_b (KNOWN AS E_b) FOR MILITARY BAND
In Pasteboard Boxes



Nos. R16—R16½ Nos. R18—R18½ Nos. R20—R20½
R120—R120½ Nos. R21—R21½ Nos. R22—R22½ Nos. R5—R5½
R50—R50½ Nos. R3—R3½ R300—R300½

HIGH PITCH

Key of D (C)		Key of E _b (D _b)	
No.	Each	No.	Each
R14—Key of D, grenadilla, 1 key, German silver trimmed..	\$0.75	R14½—Key of E _b , grenadilla, 1 key, German silver trimmed	\$0.75
R16—Key of D, grenadilla, with tuning slide, 1 key, German silver trimmed	1.00	R16½—Key of E _b , grenadilla, with tuning slide, 1 key, German silver trimmed	1.00
R18—Key of D, grenadilla, with tuning slide, 4 keys, German silver trimmed, cork joints.....	1.60	R18½—Key of E _b , grenadilla, with tuning slide, 4 keys, German silver trimmed, cork joints.....	1.60
R20—Key of D, grenadilla, with tuning slide, 6 keys, German silver trimmed, cork joints	2.00	R20½—Key of E _b , grenadilla, with tuning slide, 6 keys, German silver trimmed, cork joints.....	2.00
R21—Key of D, grenadilla, with tuning slide, 6 keys, German silver trimmed, cork joints, German silver lip plate and holes bushed with German silver.....	3.50	R21½—Key of E _b , grenadilla, with tuning slide, 6 keys, German silver trimmed, cork joints, German silver lip plate and holes.....	3.50
R22—Key of D, grenadilla, with tuning slide, 6 keys, German silver trimmed, cork joints, ivory head; extra quality	4.75	R22½—Key of E _b , grenadilla, with tuning slide, 6 keys, German silver trimmed, cork joints, ivory head..	4.75

LOW PITCH

No.	Each	No.	Each
R120—Same as No. R20, but Low Pitch.....	\$2.00	R120½—Same as No. R20½, but Low Pitch.....	\$2.00

MEYER PATTERN—SUPERIOR QUALITY

In Fine Velvet-lined Cases

HIGH PITCH

No.	Each
R24 —Key of D, grenadilla, with tuning slide, 6 keys, German silver trimmings, cork joints, fine ivory head..	\$6.00
R24½—Key of E _b , grenadilla, with tuning slide, 6 keys, German silver trimmings, cork joints, fine ivory head..	6.00

LOW PITCH

R124 —Key of D, grenadilla, with tuning slide, 6 keys, German silver trimmings, cork joints, fine ivory head..	6.00
R124½—Key of E _b , grenadilla, with tuning slide, 6 keys, German silver trimmings, cork joints, fine ivory head..	6.00

Ivory Heads not Warranted Against Cracking.

See page 59 for Suggestions Regarding the Care of Piccolos.
See page 6 for shipping weights.

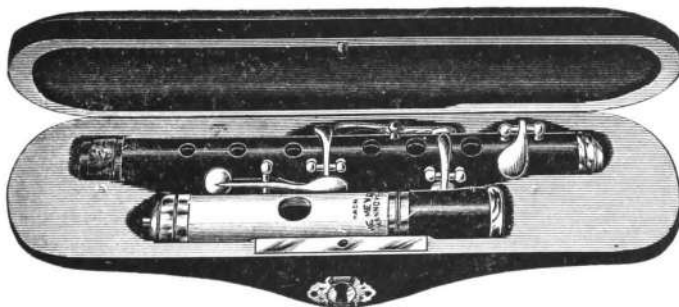

Nos. R24—R24½—R124—R124½

PICCOLOS

GEORGE CLOOS, AMERICAN MAKE
With Covered Finger Holes

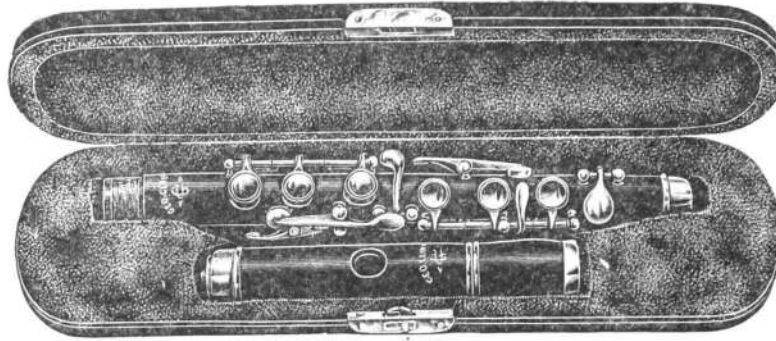

Finest Material, Finish
and Workmanship.
Low Pitch Only.
Key of C (known as D)
for Orchestra.

Guaranteed Correct in
Pitch and Scale.
Low Pitch Only.
Key of D_b (known as E_b)
for Band.

In Elegant Case.

No.		Each
R141	—Key of D, grenadilla, with tuning slide, 6 keys, ivory head, German silver trimmings, Low Pitch.....	\$20.00
R141½	—Key of E _b , grenadilla, with tuning slide, 6 keys, ivory head, German silver trimmings, Low Pitch.....	20.00

BOEHM SYSTEM PICCOLOS EMIL RITTERSHAUSEN, BERLIN

See illustration on preceding page.

Acknowledged the finest obtainable, by artists, professional and amateur, throughout Europe and America. In C (D) for Orchestra, High or Low Pitch. In D_b (E_b) for Military Band, High or Low Pitch.

No.		Each
R 3	—Key of C (D), grenadilla wood, German silver keys, covered finger holes, in fine case, High Pitch.....	\$52.50
R300	—Key of C (D), grenadilla wood, German silver keys, covered finger holes, in fine case, Low Pitch.....	52.50
R 3½	—Key of D _b (E _b), grenadilla wood, German silver keys, covered finger holes, in fine case, High Pitch.....	52.50
R300½	—Key of D _b (E _b), grenadilla wood, German silver keys, covered finger holes, in fine case, Low Pitch.....	52.50

BUFFET, CRAMPON & CO., PARIS (EVETTE & SCHAEFFER, SUCCESSORS)

See illustration on preceding page.

No.		Each
R 5	—Boehm system, key of D, grenadilla wood, German silver keys, cylindrical bore, in fine plush-lined case with swab, etc., High Pitch.....	\$40.00
R 5½	—Boehm system, key of E _b , grenadilla wood, German silver keys, cylindrical bore, in fine plush-lined case, with swab, etc., High Pitch.....	40.00
R50	—Same description as No. R5, but Low Pitch.....	40.00
R50½	—Same description as No. R5½, but Low Pitch.....	40.00

PICCOLO CASE AND FURNISHINGS



No. R4—Swab



No. R1—Case

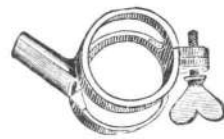

No. R13—Mouthpiece

No.		Each	Postage
R 1	—Leather covered, velvet lined.....	\$1.25	1-lb. rate

MUSIC RACKS

No.		Each	Postage
R 8	—Nickel plated, adjustable arm strap.....	\$1.00	4 cts.
R34	—Nickel plated, Burts' Patent to attach to coat.....	2.25	1-lb. rate

MOUTHPIECE

No.		Each	Postage
R13	—Britannia, adjustable, with regulating screw.....	\$0.10	2 cts.

PADS

No.		Dozen	Postage
R 2	—Bladder covered. (For sizes, see Clarinet Pads, page 66).....	\$0.20	1 ct.
R 3	—Kid covered. (For sizes, see Clarinet Pads, page 66).....	.20	1 ct.
R 7	—Bladder covered, for Boehm Piccolos.....	Per set, 1.00	1 ct.

SWABS

No.		Each	Postage
R 4	—Silk, variegated colors.....	\$0.25	2 cts.



No. R8—Music Rack

FIFES, FLAGEOLETS AND PICCOLO FLAGEOLETS



No. R2



Nos. R3 and R5



No. R10. Crosby Model. This Fife, in B_b, is the instrument used by practically all fife and drum corps.



No. R12—Flageolet
Each Instrument in a neat pastboard box



No. R14—Piccolo and Flageolet Combined
A unique little Instrument—Easy to play, very sweet tone



Nos. R9—R11



Nos. R1—R3
Key of D, 11 inches in length



No. R14
In the Keys of B_b, C, D, E_b, F or G—Specify which is wanted



No. R80



No. R82



No. R84

FIFES

Either Key of B_b for use in Fife and Drum Corps or Key of C for use with Piano—Specify which is wanted.

No.	Each	Postage
R 2—Imitation ebony, nickel plated ferrules	\$0.25	1-lb. rate
R 3—Rosewood, brass ferrules	.30	1-lb. rate
R 5—Cocoa, nickel plated ferrules	.50	1-lb. rate
R 10—Ebony, Crosby model, with long, tapering German silver ferrules, large calibre, full round tone, perfectly tuned, superior quality	1.00	1-lb. rate
Per dozen, \$10.50.		

FIFE MOUTHPIECES

No.	Each
R13—Britannia, with adjustable screw, for wood Fifes	\$0.10
R14—Britannia, with adjustable screw, for metal Fifes	.10
Postage—Nos. R13—R14, 2 cts. each.	



FLAGEOLETS

In pasteboard box.

No.	Each	Postage
R 9—D, boxwood, 1 key, German silver trimmed	\$1.50	1-lb. rate
R10—D, grenadilla, 1 key, German silver trimmed	1.75	1-lb. rate
R12—D, grenadilla, 4 keys, German silver trimmed	2.50	1-lb. rate
R14—D, grenadilla, 6 keys, German silver trimmed	3.00	1-lb. rate

COMBINED FLAGEOLET AND PICCOLO

In pasteboard box.

No.	Each	Postage
R20—D, grenadilla, 1 key, German silver trimmed	\$2.50	1-lb. rate
R22—D, grenadilla, 4 keys, German silver trimmed	3.00	1-lb. rate
R24—D, grenadilla, 6 keys, German silver trimmed	3.50	1-lb. rate

TIN FLAGEOLETS

No.	Each	Postage
R 9—10-inch, wood plug mouthpiece	\$0.05	3 cts.
R10—12-inch, wood plug mouthpiece	.10	3 cts.
R11—14-inch, wood plug mouthpiece	.15	3 cts.

CLARK'S LONDON FLAGEOLETS

Self-Instructor and Music with each Instrument.

No.	Each	Postage
R 1—Tin	\$0.10	3 cts.
R 2—Brass	.15	3 cts.
R 3—Nickel	.20	3 cts.

U. S. NICKEL FLAGEOLETS

Self-Instructor and Music with each Instrument.

No.	Each	Postage
R14—Nickel plated, brass, any key	\$0.20	3 cts.

PARISIAN FLAGEOLETS

No.	Each
R80—Cast metal, French make, key of D, Whistle Form	\$0.50
R82—Cast metal, French make, Key of D, Piccolo Form	.65
R84—Cast metal, French make, key of D, Flageolet Form	.75
R84½—Flageolet Form, key of D, nickel plated, American make	.20
Postage—R80, R82 and R84, 1-lb. rate; R84½, 4 cts.	

BUGLES AND TRUMPETS



No. R91
Hunting Horn

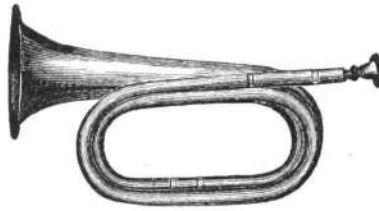

Nos. R93—R93 $\frac{1}{2}$ N
Officers' Bugles

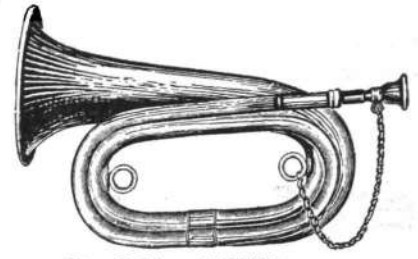

Nos. R94 and R94N
Artillery Bugle. Key of B \flat
U. S. Army Regulation

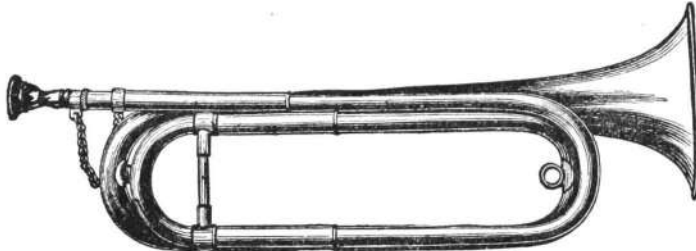

Nos. R95 and R95N—U. S. Army Regulation Trumpet
Key of F, with Tuning Slide

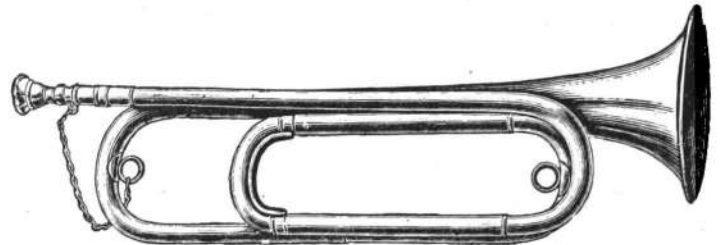

Nos. R96 and R96N—U. S. Army Regulation Trumpet
Key of G, with F Slide

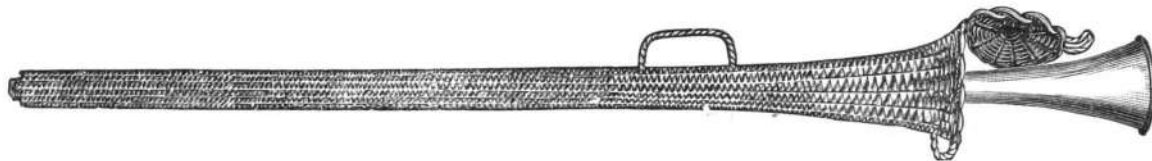

No. R99—English Coach or Tally-Ho Horn

POST AND HUNTING HORNS

No.	Each
R90 —Brass, French model, two turns, long pattern.....	\$1.25
R90N—Nickel plated, French model, two turns, long pattern....	1.75
R91 —Brass, French model, three turns, round pattern....	1.50

OFFICERS' BUGLES

No.	Each
R93 —Brass, French model, key of C.....	\$2.25
R93N —Nickel plated, French model, key of C.....	3.00
R93 $\frac{1}{2}$ —Brass, French model, key of B \flat	2.25
R93 $\frac{1}{2}$ N—Nickel plated, French model, key of B \flat	3.00

U. S. ARMY REGULATION BUGLES

French Make

Highest Quality Manufactured. Adopted by United States Government. Large Bore, Heavy Brass, Finest Workmanship, Easy Blowing. These instruments must not be confused with the cheap, flimsy German and Austrian imitations offered at slightly lower prices.

No.	Each	No.	Each
R94 —Artillery Bugle, key of B \flat , heavy polished brass, chained mouthpiece	\$4.50	R95N—Same as R95, but heavily nickel plated.....	\$5.50
R94N—Same as R94, but heavily nickel plated.....	5.50	R96 —Infantry or Cavalry Trumpet, key of G, with F slide, heavy polished brass, chained mouthpiece.	4.00
R95 —Cavalry Trumpet, key of F, with tuning slide, heavy polished brass, chained mouthpiece.....	4.50	R96N—Same as R96, but heavily nickel plated.....	5.00

ENGLISH COACH OR TALLY-HO HORN

No.	Each
R99—Copper, German silver trimmed, 40 inches long in basket	\$5.00

REGULATION BUGLE CORDS

No.	Each
R1—Finest quality, double worsted, with tassels—red, yellow, blue or white; specify color wanted (postage 4 cts.)	\$1.25

DRUM MAJORS' BATONS

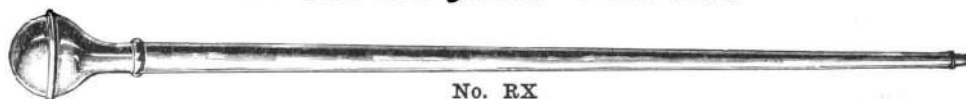

No. RX

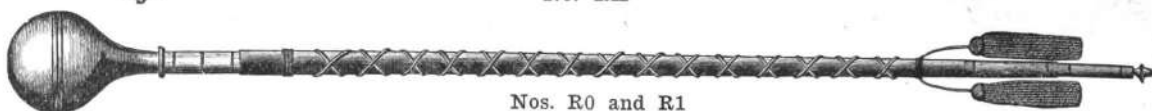

Nos. R0 and R1

No.	Each	No.	Each
R0—Full regimental size, diameter of head 4 inches, entire length 46 inches, nickel-plated head, unscrews in center, polished ebonized stick with gilt cord and tassels	\$7.00	R1—Full regimental size, diameter of head 4 inches, entire length 46 inches, nickel-plated head, unscrews in center, highly polished rosewood stick with gilt cord and tassels.....	\$10.00
RX—Full nickel-plated ball, staff and ferrule.....	8.00		

Drum Majors' Batons are unavailable owing to their length.

TOY AND YOUTHS' DRUMS

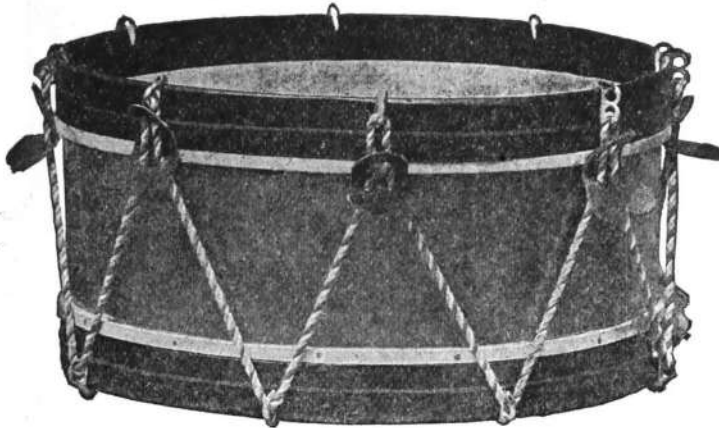

No. R4 1/2

NICKEL SHELL—LOW MODEL

Fancy Colored Cord, Leather Ears

No.	Each
R4 1/2—13-inch, nickel shell, calfskin batter head.....	\$2.50

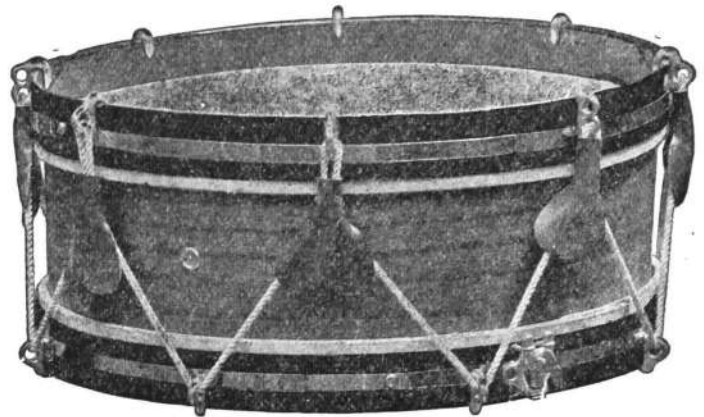

No. R5 1/4

WOOD SHELL—LOW MODEL

Nickel Band inlaid around Hoops, good Cord and Ears

No.	Each
R5 1/4—13-inch, wood shell, calfskin batter head.....	\$3.25



No. R6 1/2

NICKEL SHELL—LOW MODEL

Nickel Band inlaid around Hoops, good Cord and Ears

No.	Each
R6 1/2—14-inch, nickel shell, calfskin batter head.....	\$4.50

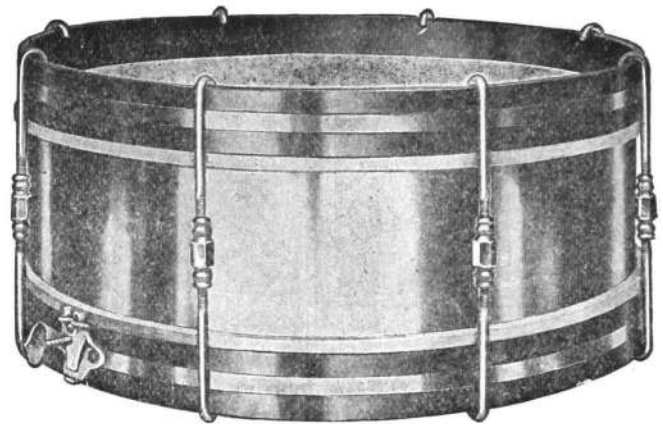

No. R7 1/2

NICKEL SHELL—FINE QUALITY

Nickel Band inlaid around Hoops, Eight Nickel-plated Rods

No.	Each
R7 1/2—14-inch nickel shell, calfskin batter head.....	\$5.00

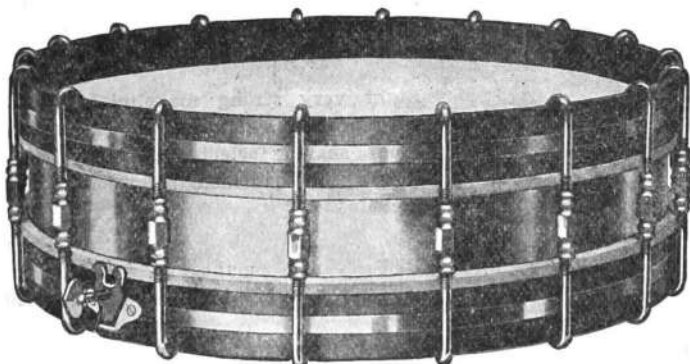

No. R8 1/2

NICKEL SHELL—ORCHESTRA PATTERN

Finest Quality

Nickel Band inlaid around Hoops, Eighteen Nickel-plated Rods

No.	Each
R8 1/2—14-inch, nickel shell, calfskin batter head.....	\$6.00

See page 6 for shipping weights.

SNARE DRUMS

Moderate
Prices
Good Tone
Excellent
Quality

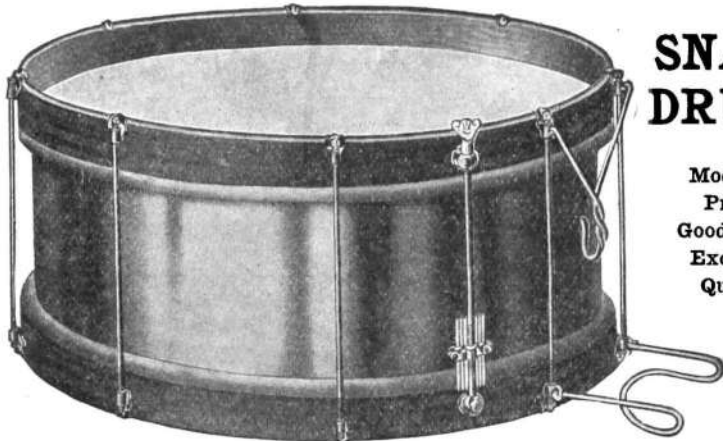

Nos. R19—R20



Nos. R22—R23—R25—R26

SUPERIOR PRUSSIAN DRUMS

Absolutely the best instrument manufactured at its price.

Bodies of veneered birdseye maple or mahogany and hoops of hard maple nicely stained and all finely finished. Rods are finely nickel plated with pressed steel hooks of a special shape with long sleeves and threads. Independent, adjustable long pattern snare strainer, eight waterproof snares, fine quality calf batter head. A patent folding knee rest and belt hook is furnished, also a pair of fine rosewood sticks.

No.	Each
R19—14-inch birdseye maple shell, 4 inches high, 7 rods....	\$8.50
R20—14-inch mahogany shell, 6 inches high, 7 rods.....	9.00

"EUREKA" METAL SHELL DRUMS

Prussian Pattern.

Bodies of brass or nickel plated and hoops of hard maple, ornamented with gilt decalcomania; nickel-plated rods with pressed steel hooks; knee rest; belt chain and hook; adjustable long pattern snare strainer; eight waterproof snares; fine quality calf heads. Rosewood sticks included.

No.	Each
R22—14-inch polished brass shell, 6 inches high, 7 rods....	\$ 9.25
R23—14-inch nickel-plated shell, 6 inches high, 7 rods.....	10.00
R25—16-inch polished brass shell, 8 inches high, 8 rods....	11.00
R26—16-inch nickel-plated shell, 8 inches high, 8 rods.....	12.00



No. R28

"ACME" ORCHESTRA DRUM

Prussian Pattern. Four-inch, Nickel-plated Shell. Entire height, six inches.

Extensively used in orchestras and also one of our most popular Drums with band drummers who prefer a Low Model Instrument. Shell of brass, heavily nickel plated; hoops of hard maple inlaid with a German silver band a half-inch wide. Ten nickel-plated rods with long sleeve non-stripping pressed steel hooks, folding knee rest, nickel-plated belt hook, eight waterproof snares, two best quality calf heads and patent adjustable long pattern snare strainer. Fine polished rosewood sticks included.

No.	Each
R28—16-inch nickel-plated shell, 10 rods.....	\$12.00



No. R27

U. S. GOVERNMENT DRUM

This Drum is very substantially made and will stand long and hard service. It is extra well constructed, the body of veneered mahogany and the hoops of hard maple, finished in ebony and with two stripes inscribed around them, making a neat, finished appearance. The body is ornamented with the U. S. shield in red, white and blue. Eight heavily nickel-plated rods, with pressed steel hooks. It has long pattern adjustable snare strainer, eight waterproof snares and fine quality calf heads; knee rest, belt hook. Pair of fine polished rosewood sticks included.

No.	Each
R27—16-inch dark mahogany shell, 8 inches over all, 8 rods....	\$12.50

SINGLE HEAD DRUM

Very light in weight, yet strongly made, the construction of this Drum is such that it will stand the severest strain. The body is mahogany veneered and neatly finished inside and outside. The hoop is veneered of contrasting colored wood, and is inlaid with a polished German silver band.

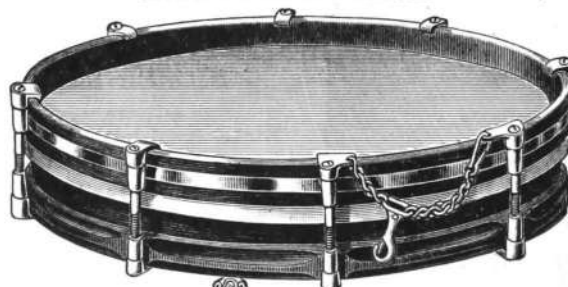

No. R39

Eight very strong nickel-plated rods with pressed steel hooks; eight waterproof snares; selected calfskin head. A pair of polished rosewood sticks included.

No.	Each
R39—14-inch mahogany shell, 3 inches high, 8 rods....	\$11.00

NOTE—In comparing our prices on Drums with those in Eastern catalogues, don't forget that express charges from New York, Chicago, St. Louis, etc., are enormous, double the ordinary rates. Our prices are lower than the Eastern rates after express-age has been added.

“VICTOR” REGIMENTAL OR CORPS DRUMS

Dimensions over all, 18 x 12 inches
SPLENDID, DEEP, POWERFUL TONE
EXCEPTIONALLY WELL CONSTRUCTED

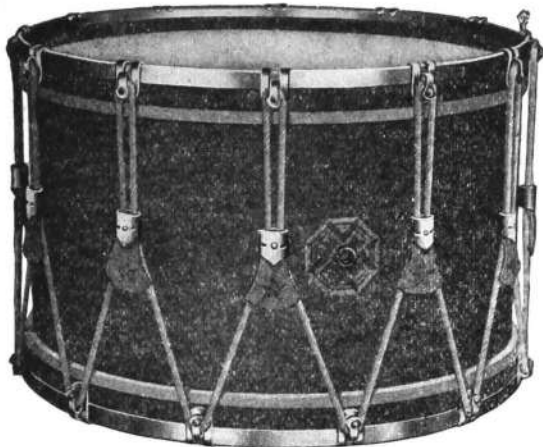

Nos. R63, R65



No. R67

Just what their name implies: Better than all others in the world. They are thoroughly well made, finely polished and beautifully finished throughout. Hoops and flesh hoops perfectly fitted. Will not warp. Fitted with 12 adjustable ears, the strongest, best and handiest manufactured. Made of nickel-plated, heavy tempered steel and the best quality of leather. Best Calfskin heads.

The roller hooks are a feature of “Victor” Corps Drums Nos. R63 and R65. They are set close together (24 on every drum), reduce to a minimum the wear on the cord and make it possible to strain the heads much tighter than with the ordinary hooks. The steel roller hooks are a new pattern which lie very flat on the hoops and do not project above them. Long pattern snare strainer and 12 waterproof snares on every drum.

All “Victor” Corps Drums Have Shells 17 Inches in Diameter, 10 Inches Deep (18 x 12 hoops included). Price Includes a Pair of Best Polished Ebony Sticks

No.	Each
R61—Mahogany shell, braced with center hoop, natural finished hoops, 24 plain cord hooks, 12 braces, 12 waterproof snares.	\$12.50
R63—Birdseye maple shell, braced with center hoop, with inlaid star of fancy colored woods; rosewood veneered hoops, 24 steel roller hooks, 12 braces, 12 waterproof snares.	14.00
R65—Rosewood shell, braced with center hoop, with inlaid star of fancy colored woods, rosewood veneered hoops with nickel-plated band securely spun on the edges, improving the appearance and preventing the hooks from marring the hoops; 24 steel roller hooks, 12 braces, 12 waterproof snares	16.00
R67—Same description as No. R65 but with 12 fine double-acting thumb rods with center aligning posts or supports fastening to a reinforcing hoop on the inside of the shell, which positively keeps the drum from warping or buckling and also insures a smoothly turning rod on which it is practically impossible for the threads to strip. The finest toned, most substantial and handsomest Corps Drum manufactured.	20.00

Drum Corps are respectfully requested to write for special quantity prices and terms

A CORPS DRUM FOR BOY SCOUTS OR OTHER YOUTHFUL ORGANIZATIONS ALSO IDEAL FOR CAMPAIGN CLUBS. LIGHT IN WEIGHT. LOW PRICED BUT SUBSTANTIAL

15½-inch mahogany shell, 9 inches deep (16 x 11½ over hoops), mahogany hoops, fine Italian hemp cord, substantial braces of heavy leather, adjustable snare strainer, 8 waterproof woven snares, good calfskin heads, powerful tone. A pair of rosewood sticks and a webbing sling included.



No.	Each
R1—Mahogany shell, 16 cord hooks, 8 braces, 8 waterproof snares, with sticks and sling	\$8.50

Write for Special Quantity Price

"VICTOR" PROFESSIONAL SNARE DRUMS

ABSOLUTELY THE FINEST FINISHED DRUMS MANUFACTURED

"VICTOR" SINGLE HEAD DRUM

Very Light Weight. Occupies Little Space. Just the thing for Trap Drummers. The Prettiest, Snappiest Little Drum Made. Absolutely Class A Construction. Bright, Sharp Tone. Responds Instantly

This handsome little Drum is particularly adapted to inside work, such as dances, nickel shows, theatre work, small orchestra concerts, minstrel shows, etc. It is bright, snappy and sharp to a degree not obtainable in other styles of single headed drums, and avoids all their shortcomings and errors of construction, being strong and durable beyond any other of its kind. Shell of solid rosewood veneer laid upon a heavy band of birds-eye maple, the contrast between the inside and the outside of the Drum making a very pretty effect, and producing a shell of great strength and resistance. 12 thumb rods, strong and heavy, but avoiding bulkiness through their perfect proportions and the fact that they lie absolutely flat on the hoop. Each rod is carried through a heavy support, bolted on the inside to meet the socket. Snare strainer contained within the shell, nothing outside to get damaged or out of order. 12 waterproof woven snares. First quality Angora head. Flesh hoop quarter round, adding strength to the head and beauty to the drum. Finest polished finish on shell and hoop, which is also rosewood veneered on hard maple. A pair of professional rosewood or hickory sticks included.



No. R81

Each

No. R81—14-inch Mahogany shell, 3 inches high (14½ x 4 including hoop), 12 thumb-screw rods, 12 gut snares, Angora head. \$15.00

"VICTOR" THUMB-ROD ORCHESTRA PATTERN DRUM

Shell of hand-polished rosewood veneered on hard maple; strainer hoops the same. Quarter-round flesh hoops, giving better appearance and holding head tighter without risk of cutting it. Double acting thumb rods. Thoroughly efficient and practical combination throw-off snare strainer and muffler. 12 finest gut snares, always bright and snappy. Strong, transparent Angora goat heads. All metal parts heavily nickel plated. Pair of professional rosewood or hickory sticks included.

No. R82—14-inch rosewood shell, 3 inches high (14½ x 5 over hoops), 12 thumb rods, 12 waterproof snares. \$18.00

No. R83—15½-inch rosewood shell, 3 inches high (16 x 5 over hoops), 14 thumb rods, 12 waterproof snares. 20.00

Each



Nos. R82, R83

"VICTOR" BAND DRUM

THE IDEAL DRUM FOR STREET WORK

This Drum, while sensitive and very easy playing, possesses a full, deep tone of great volume and power and is especially adapted to military band work. It has a five-ply laminated shell, built up with the grain of each layer running at a right angle to the one adjoining, insuring tremendous strength and rigidity and producing a solidity and brilliancy of tone not possessed by the drum of ordinary construction. The finish is birdseye maple, finely hand polished. The hoops are natural finish hard maple. Quarter-round flesh hoops; 12 double acting thumb rods, highly nickel plated; 12 best quality gut snares, combination snare strainer and muffler; Angora goat heads, clear, even and very tough. Pair of rosewood, ebony or hickory sticks included.



No. R84

Each

No. R84—15-inch shell, 8 inches high (16 x 10 over all), 12 thumb rods, 12 finest gut snares. \$25.00

"VICTOR" ORCHESTRA DRUM

The Ne Plus Ultra of Orchestra Drums. Finest Selected Materials. Most Painstaking Expert Workmanship

We can conscientiously recommend this Drum to professional drummers everywhere who are seeking the highest and most perfect type of wood shell orchestra drum. The lightest pianissimo and the heaviest fortissimo are obtained with equal facility; in handiness and in neatness and durability of construction it represents the highest point ever reached in drum construction. We offer it in the full confidence that it will stand the test of the most exacting work and measure up fully to all requirements.

Specifications: Shell of rosewood, veneered on hard maple; strainer hoops the same, all hand polished. 20 "Globe" double acting skeleton bracket rods; each head can be strained independently. Thoroughly efficient and practical combination throw-off snare strainer and muffler. Belt ring with globular socket. All metal parts finely nickel plated. Half-round flesh hoops, give Drum better appearance than square kind and hold head tighter without risk of cutting through it. 12 finest quality gut snares. Two finest transparent even llama heads. Price includes a pair of professional rosewood or hickory sticks.

No. R87—15½-inch rosewood shell, 3 inches high (16 x 4 over hoops), 20 bracket rods, 12 waterproof snares. \$27.50

Each



No. R87

See page 6 for Shipping Weights

“VICTOR” PROFESSIONAL ALL-METAL SNARE DRUMS

THE HIGHEST DEGREE OF PERFECTION EVER ATTAINED IN THE MANUFACTURE OF ORCHESTRA DRUMS. THE MOST SENSITIVE, SNAPPIEST DRUMS ON EARTH. THE GREATEST STRENGTH FOR THE LEAST WEIGHT

Embodying the only Thoroughly Practical and Convenient Individual Snare Tension Device on the Market. Supplied with either Thumb Rods or Individual Tension Pattern



No. R90—Thumb Screw Rods



No. R95—Individual Tension Rods

INDIVIDUAL SNARE TENSION

Note the ingenious contrivance for separately controlling the tension of each snare. By this device, a really uniform tension is secured and maintained. Patents are pending on this tension device and on the snare strainer and muffler used on these Drums.

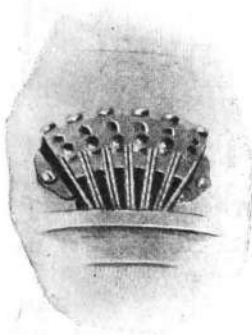

COMBINATION SNARE STRAINER AND MUFFLER

Drum can be muffled or transformed into a tom-tom, or vice versa, by a touch of a finger. Fig. 1 shows the snare strainer and muffler set. Fig. 2 shows the snare strainer and muffler released to secure tom-tom or Indian drum effect.

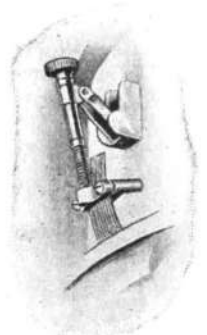
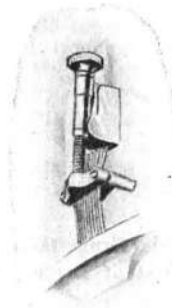

Fig. 1

Fig 2

- | | |
|---|---------|
| No. | Each |
| R90 —14 x 5 inches, solid aluminum shell, aluminum angle hoops; 10 nickel-plated thumb screw rods of the very finest quality; will not strip; selected transparent calfskin heads; 12 rawhide snares (no sticks included)..... | \$30.00 |
| R95 —Same as No. R90, but with individual tension rods instead of thumb rods (no sticks included)..... | 32.50 |

No possibility of the angle hoops warping or shell buckling in the “Victor” All-Metal Drums. The heaviest fortissimo and the lightest pianissimo obtained with equal facility. The “Victor” has greater latitude and is easier working than any other drum in the world.

THE CELEBRATED LEEDY “ALLINONE” METAL SHELL DRUMS

Satin finish, nickel-plated metal shell with cast aluminum counter hoops of double angle type which absolutely prevent the drum from warping or pulling out of shape in any manner. The upper angle extends just enough above the heads to protect them from injury without interfering with the action of the sticks, while the lower angle extends downward and entirely covers the flesh hoops.

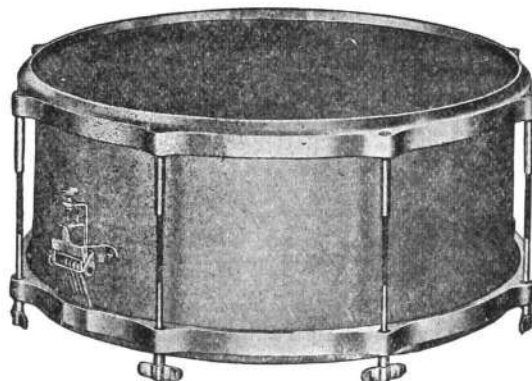

Four Sizes
14 x 4, 14 x 6, 15 x 5, 15 x 6

Flesh hoops of one-quarter by one-eighth inch steel covered with non-corrosive plate. Very little surplus required for wrapping, so a head two inches smaller than usually required can be used. The eight thumb-screw pattern rods are set in the counter hoops, preventing slipping when loosened and permitting of very quick tensioning. Equipped with utility snare strainer and muffler (Drum converted into a tom-tom by pressing small lever), transparent Uka heads and gut or coiled wire snares.

- | | |
|---|---------|
| No. | Each |
| R51 —14 x 4 inches, 8 rods (no sticks included)..... | \$37.50 |
| R53 —14 x 6 inches, 8 rods (no sticks included)..... | 37.50 |
| R56 —15 x 5 inches, 8 rods (no sticks included)..... | 37.50 |
| R57 —15 x 6 inches, 8 rods (no sticks included)..... | 37.50 |

Your old Drum accepted in part payment for a “Victor” or a “Leedy”—easy terms on the balance. Send detailed description of your instrument. Trial allowed on the “Victor” or “Leedy”—return transportation charges at our expense if not satisfactory.

THE RENOWNED "DUPLEX" SNARE DRUMS



Nos. R77 and R79

PRUSSIAN MODEL DRUMS

- | | |
|---|---------|
| No. | Each |
| R77—14-inch nickel-plated spring brass shell, 4 inches high (6 inches including hoops). Imitation rosewood hoops, long pattern nickel-plated snare strainer, 7 nickel-plated rods, 2 Jos. Reitz's Angora heads, 10 waterproof woven snares. A pair of rosewood sticks included..... | \$ 8.75 |
| R79—Same description as No. R77, but has 16-inch shell, with 8 rods..... | 11.00 |

STANDARD DUPLEX CORPS DRUM

- | | |
|---|---------|
| No. | Each |
| R5—16-inch nickel-plated spring brass shell, 6 inches high (8 inches including hoops). Rosewood veneered hoops, 8 nickel-plated Duplex rods, long pattern, nickel-plated snare strainer, 2 Jos. Reitz's Angora heads, 10 waterproof woven snares; for drum corps or general band use. Including a pair of professional rosewood sticks..... | \$16.00 |



No. R5

THE "UNIQUE" DUPLEX DRUM

This Drum is intended exclusively for fine orchestra work. It is one of the sharpest of Drums, yet has a fine brilliant tone.

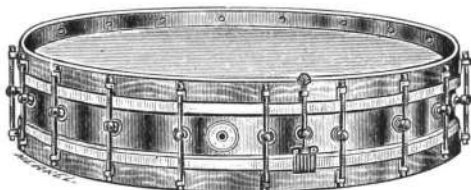

No. R210

- | | |
|--|---------|
| No. | Each |
| R210—16-inch solid maplewood shell ¼-inch thick, veneered with rosewood and polished inside and outside. Shell is 3 inches high (4 inches including hoops), 20 skeleton Duplex rods, 12 waterproof woven snares, 2 Jos. Reitz's Kangaroo heads. Including a pair of professional rosewood sticks | \$27.50 |

PERFORATED METAL BAND AND ORCHESTRA DUPLEX DRUM

This Drum is made entirely of metal, with wood-lined hoops to give it an elegant shape and promote lightness. It is a real beauty and is preferred by many as a street Drum.

- | | |
|---|---------|
| No. | Each |
| R127—16-inch polished nickel-plated spring brass shell, 6 inches high (8 inches including hoops), 12 skeleton Duplex rods, combination snare strainer and muffler, 2 Jos. Reitz's Kangaroo heads, 12 satin finish waterproof woven snares. An inclined belt hook is also included with this instrument as well as a pair of professional rosewood sticks..... | \$30.00 |

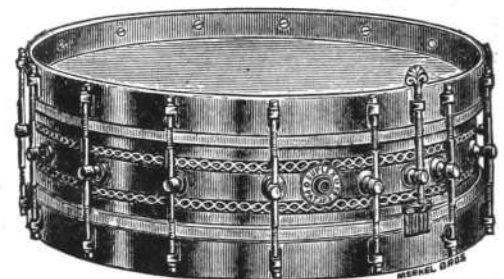

No. R127

THE "DAISY" SINGLE HEAD DUPLEX DRUM

A better than ordinary article, though low priced. The shell is veneered on both sides, rosewood outside, birdseye maple inside, and the drum is finely and substantially built throughout.

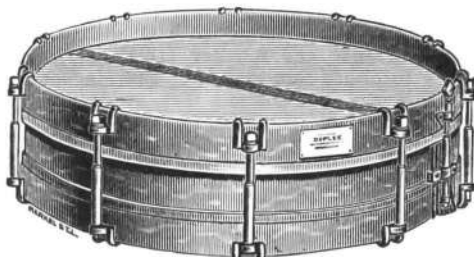

No. R228

- | | |
|---|---------|
| No. | Each |
| R228—14-inch shell, 4½ inches high, including hoop; 10 improved nickel-plated sleeve rods, Jos. Reitz's Kangaroo head, waterproof woven snares. Including a pair of professional rosewood sticks..... | \$12.50 |

In comparing our Drum prices with those of Eastern dealers, don't fail to take the transportation charges into consideration. Our prices are lower than Eastern rates when these charges have been added.

See page 6 for Shipping Weights

BASS DRUMS

REGULATION PATTERN



Solidly built, thoroughly substantial Drums which will withstand hard service. Shells adequately reinforced. Excellent tone quality.

These Drums must not be confused with the numerous flimsily constructed Drums of similar outward appearance but which have little more tone than is obtained by beating a barrel.

Nos. R1—R14 and R1½—R14½

GUARANTEED TO GIVE SATISFACTION. STRONG AND DURABLE. SHELLS REINFORCED IN SUCH MANNER AS TO PREVENT WARPING. HOOPS PERFECTLY FITTED. EXCELLENT TONE

Rosewood or birdseye maple shell. Selected ebonized maple hoops. Fine Italian hemp cord, long pattern cord hooks. Patent non-slipping detachable metal-bound braces. Best Quality heads. Furnished with chamois skin head stick.

All Shells 12 inches deep.

Birdseye Maple Shell No.	Mahogany Shell No.		Each
E 1	R 1½	24-inch, 1 calf and 1 sheep head, 12 braces.....	\$13.50
E 2	R 2½	24-inch, 2 calf heads	15.00
E 3	R 3½	26-inch, 1 calf and 1 sheep head, 12 braces.....	15.00
E 4	R 4½	26-inch, 2 calf heads	17.50
E 5	R 5½	28-inch, 1 calf and 1 sheep head, 13 braces.....	17.00
E 6	R 6½	28-inch, 2 calf heads	19.50
E 7	R 7½	30-inch, 1 calf and 1 sheep head, 14 braces.....	18.50
E 8	R 8½	30-inch, 2 calf heads	21.00
E 9	R 9½	32-inch, 1 calf and 1 sheep head, 15 braces.....	21.00
E10	R10½	32-inch, 2 calf heads	23.50
E12	R12½	34-inch, 2 calf heads, 15 braces.....	28.00
E14	R14½	36-inch, 2 calf heads, 16 braces.....	30.00

Prices on larger sizes upon application.

PRUSSIAN PATTERN

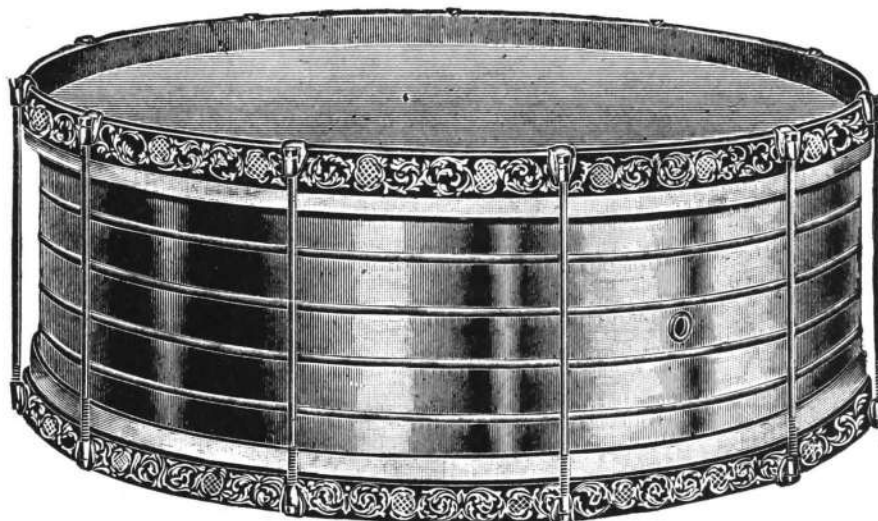

Finely polished corrugated nickel-plated shell. Decalcomania ornamented ebonized hoops.

White metal-plated rods. Two selected calfskin heads. Chamois skin head stick included.

Nos. R15—R19

All Shells 9½ inches deep.

No.		Each
E15	24-inch, 2 calfskin heads.....	\$17.50
E16	26-inch, 2 calfskin heads.....	20.00
E17	28-inch, 2 calfskin heads.....	22.50
E18	30-inch, 2 calfskin heads.....	25.00
E19	32-inch, 2 calfskin heads.....	27.50

"VICTOR" PROFESSIONAL BASS DRUMS

THE FINEST BASS DRUMS ON THE MARKET

Equipped with Center Braced Thumb Screw Rods. Chamois Skin Head Stick Included



Our prices on these Drums are no indication of their quality. By comparison they are almost ridiculously low.

We invite comparison of these Drums with any others on the market priced up to 25 per cent more.

The shells of these Drums are of selected hand-polished mahogany and are most carefully constructed with inside reinforcements at top and bottom edges and center bracing hoops. The strainer hoops are of plain hard maple, natural finish. The natural finish hoop is a guarantee of its being selected material. When hoops are ebonized or otherwise colored, there is the chance of using material which is not quite so fine, as any little defects can be covered up, but in a plain natural finish hoop every little imperfection would show out at once. Further, the plain hoop is always the best looking, as it can very easily be retouched and repolished after being scratched and then looks like new again, whereas fancy colors, and black especially, show up the slightest scratches very prominently, and it is very difficult to eliminate them.

The greatest improvement in these Drums over the ordinary rope or rod bass drum lies in the thumb-screw rods, with a center support in the middle of the shell, which positively keeps the Drum from warping or buckling, and also makes the rod practically indestructible.

Chamois Skin Head Stick Included in the Following Prices

No.		Each
R187	—24-inch mahogany shell, 12 inches high, 10 rods, 2 finest calfskin heads	\$18.50
R189	—26-inch mahogany shell, 12 inches high, 10 rods, 2 finest calfskin heads	21.00
R191	—28-inch mahogany shell, 14 inches high, 12 rods, 2 finest calfskin heads	24.00
R193	—30-inch mahogany shell, 14 inches high, 13 rods, 2 finest calfskin heads	26.00
R195	—32-inch mahogany shell, 14 inches high, 14 rods, 2 finest calfskin heads	29.00
R199	—36-inch mahogany shell, 16 inches high, 16 rods, 2 finest calfskin heads	37.50



POLE TYMPANIES

AN EXCELLENT TYMPANY AT HALF THE USUAL PRICE

American Manufacture

No.		Per pair
R2½	—24- and 26-inch copper, one-piece shells, nickel handles, Angora heads, with folding japanned iron stands. Including sticks	\$75.00

TYMPANY STICKS

No.		Per pair
R89	—Hickory handle, felt head, professional model.....	\$1.75

In comparing our prices on Bass Drums with those of Eastern dealers, it must be remembered that the freight rates are from about 13 cents to about 15 cents per lb., which means that the transportation charge on a single Drum would be anywhere from \$3.00 to \$7.50 according to its size and the point of shipment. The express charge would be considerably higher still.

BASS DRUM AND CYMBAL BEATERS

(PEDALS)

"VICTOR"

HEEL-CONTROLLED BEATERS

The most practical Pedals on the market. Neat, compact, light, yet very strong. Equally good for all classes of work. Very convenient; attached and ready for use in an instant. This Pedal is a radical departure from almost all others, in that the stroke is controlled by the heel instead of the toe. Greater precision is obtained and the foot positively does not tire in the heaviest work. The double Pedal No. R8 permits of cymbal and drum being beaten independently or together. Made of the best selected hard maple; footboard covered with corrugated rubber. A large majority of our local trap drummers use this Pedal.

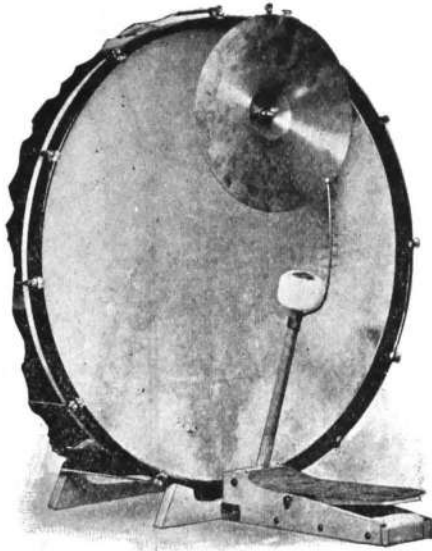

Victor Pedal No. R7

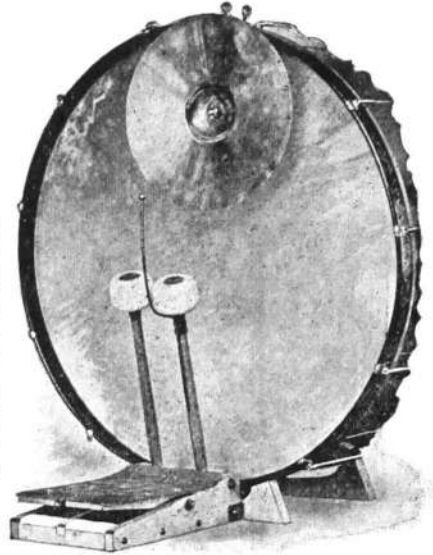

Victor Pedal No. R8

No.		Each
R7—Single Pedal, complete with racks for drum and cymbal holder, but without cymbal.....		\$ 5.00
R8—Double Pedal, complete with racks for drum and cymbal holder, but without cymbal.....		7.00

"VICTOR"

TOE-CONTROLLED BEATERS

Absolutely the best Pedal of its character manufactured. The ideal Beater for the jobbing drummer because of its compactness, light weight and great efficiency.

Points of superiority over other toe pedals: The Beater is so arranged that it strikes the Drum where the tone is produced. The cymbal striker is attached to the Beater-rod in such manner that it can be regulated to any desired height and distance so as to strike the cymbal to the best advantage; it can also be thrown off entirely when desired. The Beater-rod is fluted at the end to give the set screw a firm hold upon the rocker arm, thus preventing the rod from turning out of position. The clamp piece at the bottom of the base is constructed in such a manner as to enable the foot-piece to adjust itself to the unevenness of any floor on which the Pedal may stand, without affecting its firm hold upon the Drum



Victor Pedal No. R4

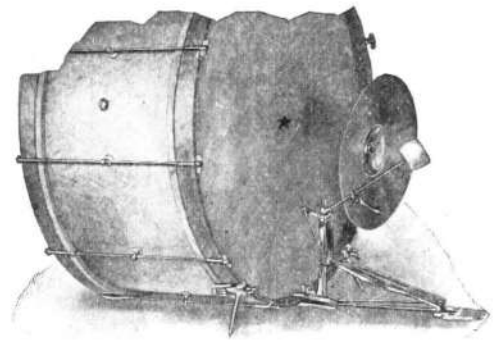

Victor Pedal No. R4 in position

rim. The spring or pull-back device is so applied as to give elasticity to the beater and can be regulated to give the requisite tension for any desired length of stroke by the simple turning of a regulator screw which is conveniently located at the center of the standard. Another novel feature is the arrangement of the heelpiece, which is hinged to the footpiece, permitting it to be folded over to make a more compact package when carrying. Observe that the foot- and heelpiece conform perfectly to the shape of the shoe. The Pedal is made entirely of metal, is nickel plated and polished throughout, and despite its light weight, is very substantially constructed and will withstand the hardest kind of usage.

No.		Each
R4—Victor Toe Pedal complete, including spurs and cymbal holder (no cymbal)		\$ 8.50

LUDWIG DRUM AND CYMBAL BEATER

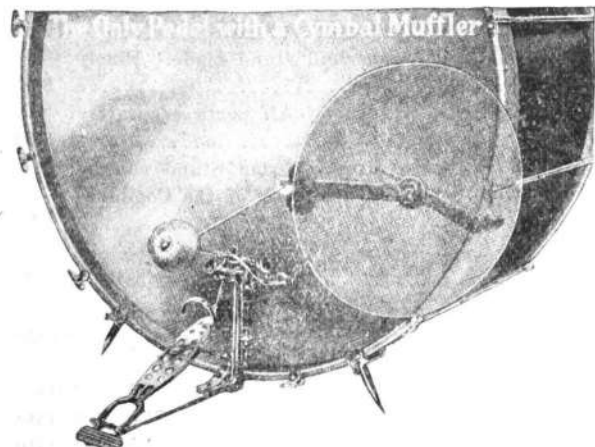

No.		Each
R5—The lightest, quickest, neatest and most responsive pedal on the market. Cymbal holder and spurs included, but no Cymbal. Nickel plated throughout		\$8.00

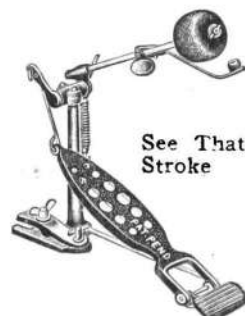

See That Stroke

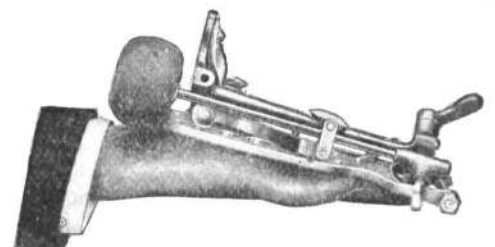

See page 6 for Shipping Weights

DRUM STANDS AND MUSIC RACKS



No. R8



No. R10

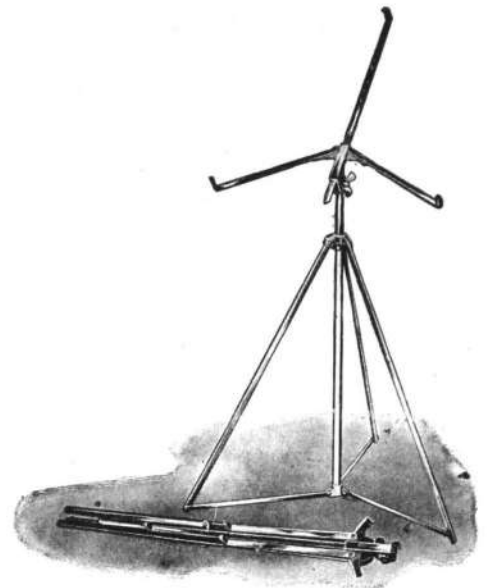

No. R11

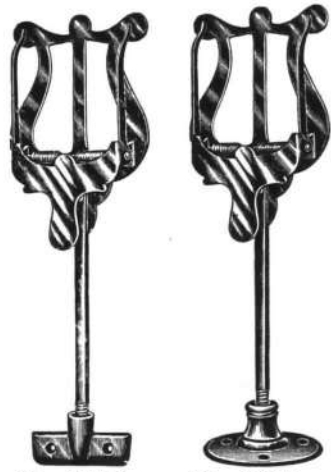

No. R64 1/2

No. R65 1/2



No. R36—Burt's Patent

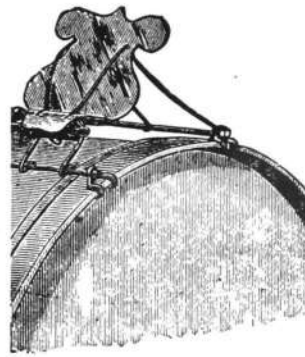

No. R38—Burt's Patent

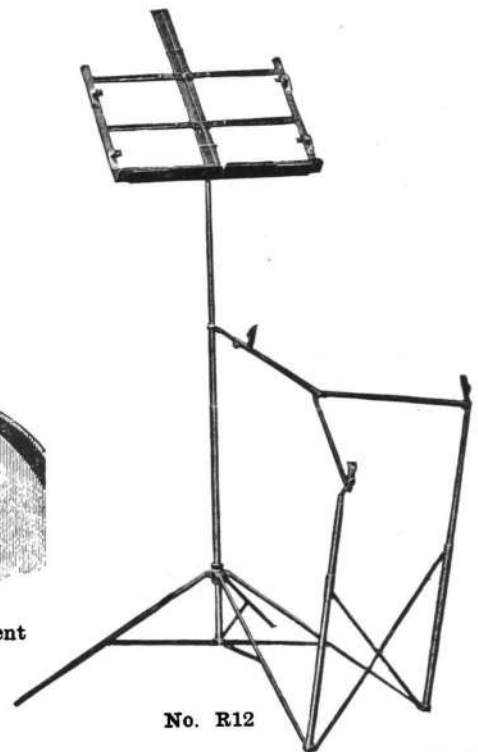

No. R12

STANDS

No.		Each
R 8	Mills Drum Stand, fits any size drum, adjusts to any angle. Finely nickel plated	\$2.50
R10	—“Victor” Snare Drum Stand, fits any size drum, adjusts to any angle. The best and most rigid stand made. Finely nickel plated. Folds compactly and is quickly adjusted.....	3.00
R11	—“Leedy” Snare Drum Stand. Easily and quickly adjusted to any height, angle or size of drum. All parts accurately machined, making it rigid and substantial.....	5.00
R12	—Mills Combination Drum and Music Stand. Heavily nickel plated. Adjustable to any size drum. Drum Stand can be adjusted to any height from a minimum of 14 inches to a maximum of 30 inches. Weight, complete, of the Combination, including Desk, 66 ounces.....	6.50

MUSIC RACKS

No.		Each	Postage
R64 1/2	—Drum Rack, nickel, snare drum, with socket to screw on drum	\$1.00	4 cts.
R65 1/2	—Drum Rack, nickel, bass drum, improved socket and stand.....	1.00	4 cts.
R36	—Drum Rack, nickel, snare drum, to attach to coat, Burt's patent	2.25	1-lb. rate
R38	—Drum Rack, nickel, bass drum, to attach to cord or rods, Burt's patent	1.75	1-lb. rate

DRUM CASES, BELTS AND SLINGS

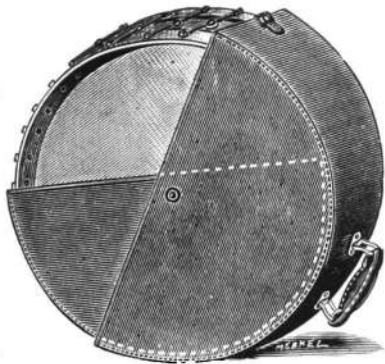

Nos. R10, R11—Canvas
Nos. R8, R9—Seal Grain Keratol



Nos. R12, R14



Nos. R102, R104



No. R213

CASES

- | No. | Each |
|--|--------|
| R 3—Heavy ducking bag, leather bound, leather bound handle, leather straps; for Regimental or Corps Drums up to 18 x 12 inches | \$1.75 |
| R10—Heavy canvas revolving swing case, bound edges, flannel lined, leather handle, pocket for sticks; for Drums up to 16 inches in diameter, 6 inches high (hoops included) | 3.50 |
| R11—Same as No. R10; for Drums up to 8 inches high (hoops included) | 3.50 |
| R 5—Canvas covered case, leather bound, flannel lined, fine leather handle and straps, outside pocket for sticks; for 15½- or 16-inch Drums up to 6½ inches high | 4.00 |
| R12—Round case of finest black fibre. Very light and extremely durable. Neat in appearance. Telescopes to accommodate any depth Drum. For 14-inch Drum..... | 5.00 |
| R14—Same as No. R12 but for 15-inch Drum | 5.00 |
| R 8—Black seal grain keratol covered, thoroughly waterproof, revolving swing, flannel lined, hand sewed, heavy strap, leather edges and handle, pocket outside for sticks; for 15½- or 16-inch Drums, 4 or 4½ inches high (hoops included) | 6.00 |
| R 9—Same as No. R8; for Drums 15½ or 16 x 6 inches (hoops included) | 6.00 |
| R 6—Suit case style. Sides and ends made of wood, top and bottom of government fibre, covered with waterproof seal grain keratol; flannel lined, nickel-plated spring lock and trunk catches, leather corners, substantial handle; size 17¼ x 17¼ x 6½; room for small traps | 6.00 |

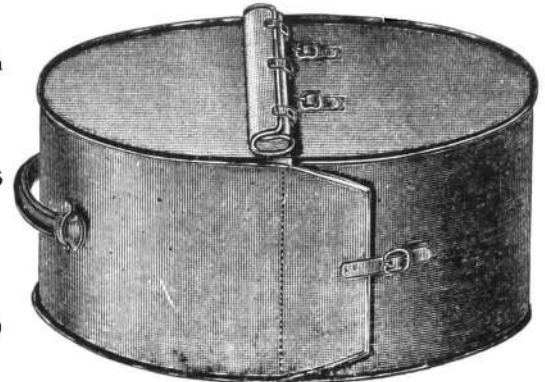

No. R5

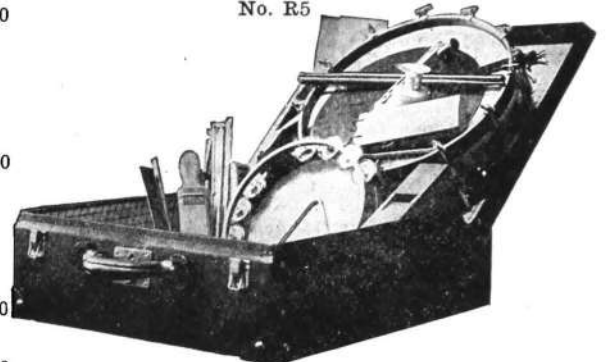

No. R6

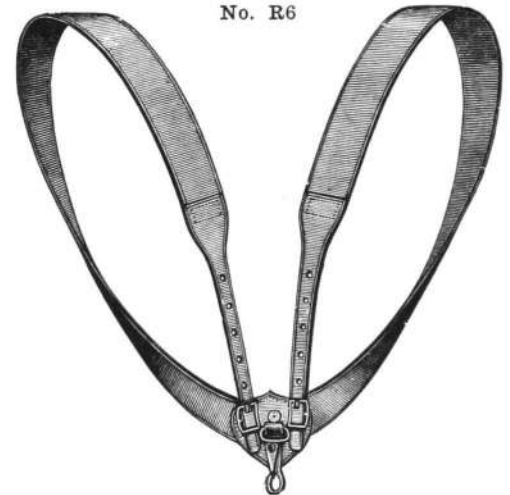

Nos. R108, R110

BELTS AND SLINGS

- | No. | Each | Postage |
|--|--------|------------|
| R102—Webbing, striped, with snap hook for Boys' Snare Drum | \$0.20 | 2 cts. |
| R104—Webbing, white, finest quality, snap hook for Regulation Snare Drum | .25 | 3 cts. |
| R106—Webbing, white, finest quality, waist belt, for Prussian Model Drum | .25 | 3 cts. |
| R108—Webbing, striped, finest quality, snap hook for Bass Drum | .45 | 1-lb. rate |
| R110—Webbing, white, finest quality, snap hook for Bass Drum | .45 | 1-lb. rate |
| R112—Leather, russet waist belt, strap and buckle, ring for belt hook; for Snare Drum .. | .60 | 1-lb. rate |
| R213—White webbing, 2 inches wide, U. S. Army Regulation with solid brass tongueless buckle and brass slide loop, firmly riveted, all hand made and stitched; sling can be lengthened or shortened; for Snare Drum | 1.50 | 1-lb. rate |
| R215—White webbing, 2¼ inches wide, U. S. Army Regulation, with two solid brass tongueless buckles and slide loops, all hand made; sling can be lengthened or shortened; for Bass Drum..... | 2.00 | 1-lb. rate |

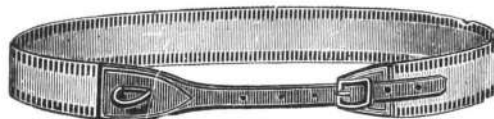

Nos. R106, R112

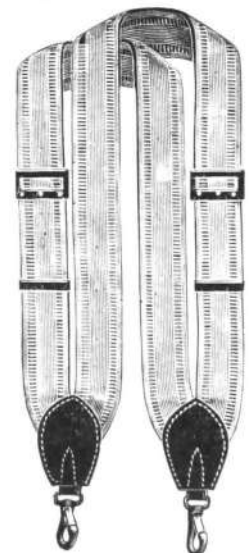

No. R215

See page 6 for Shipping Weights of Drum Cases

DRUM FURNISHINGS

DRUM CORD

Italian Hemp, Best Quality, Unbleached



Nos. R39—R43

No.	Each	Postage
R39—32-foot piece, for 16-inch drum	\$0.50	1-lb. rate
R40—35-foot piece, for 24 and 26-inch drums	.60	1-lb. rate
R41—40-foot piece, for 28 and 30-inch drums	.75	1-lb. rate
R42—50-foot piece, for 32 and 34-inch drums	.90	1-lb. rate
R43—55-foot piece, for 36-inch drum	1.00	1-lb. rate

DRUM HEADS

In Ordering Drum Heads, Always State Whether Snare or Batter Head Is Wanted

GENUINE ROGERS SUPERIOR QUALITY CALFSKINS

No.	Each	No.	Each
R12—12-inch for 10 -inch drum, tamborine or banjo	\$0.75	R28—28-inch for 24-inch drum	\$4.00
R13—13-inch for 11 -inch drum, tamborine or banjo	.90	R30—30-inch for 26-inch drum	4.25
R14—14-inch for 11½-inch drum, tamborine or banjo	1.10	R32—32-inch for 28-inch drum	4.75
R16—16-inch for 13 -inch drum, tamborine or banjo	1.25	R34—34-inch for 30-inch drum	5.25
R18—18-inch for 14-inch drum	1.50	R36—36-inch for 32-inch drum	5.60
R20—20-inch for 16-inch drum	1.75	R38—38-inch for 34-inch drum	6.00
R22—22-inch for 18-inch drum	2.00	R40—40-inch for 36-inch drum	6.50

CALF SLUNK HEADS FOR STREET DRUMS—EXCELLENT QUALITY

SNARE DRUM		BASS DRUM	
No.	Each	No.	Each
R318—18-inch for 14-inch drum	\$0.90	R328—28-inch for 24-inch drum	\$2.50
R319—19-inch for 15-inch drum	1.00	R330—30-inch for 26-inch drum	3.00
R320—20-inch for 16-inch drum	1.15	R332—32-inch for 28-inch drum	3.40
R321—21-inch for 17-inch drum	1.25	R334—34-inch for 30-inch drum	3.75
R322—22-inch for 18-inch drum	1.35	R336—36-inch for 32-inch drum	4.25
		R338—38-inch for 34-inch drum	4.75
		R340—40-inch for 36-inch drum	5.50



THE LEEDY MFG. CO'S CELEBRATED "UKA" SNARE DRUM HEADS

No.	Each
R618—18-inch for 14-inch drum	\$1.85
R619—19-inch for 15-inch drum	2.00
R620—20-inch for 16-inch drum	2.25

JOS. REITZ'S KANGAROO AND ANGORA DRUM HEADS

KANGAROO

ANGORA

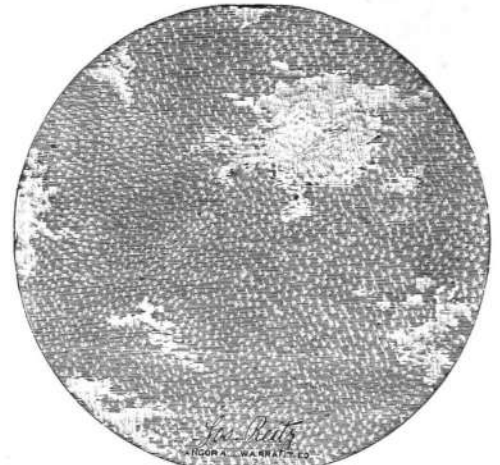
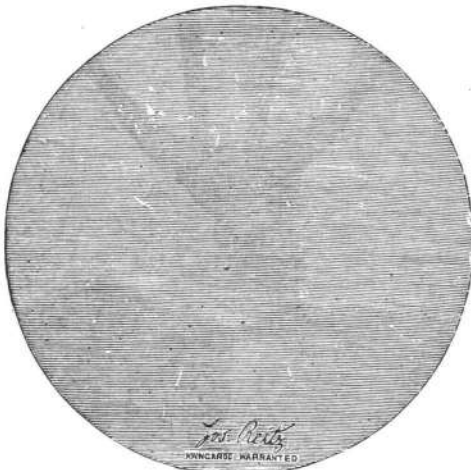

None Genuine Without Above Brand Stamped on Each Head

None Genuine Without Above Brand Stamped on Each Head

KANGAROO SNARE DRUM

ANGORA SNARE DRUM

ANGORA BASS DRUM

No.	Each	No.	Each	No.	Each
R218—18-inch for 14-inch drum	\$2.00	R119—19-inch for 16-inch drum	\$1.35	R130—30-inch for 26-inch drum	\$2.75
R219—19-inch for 16-inch drum	2.25	R120—20-inch for 17-inch drum	1.65	R132—32-inch for 28-inch drum	3.00
R220—20-inch for 17-inch drum	2.50	R122—22-inch for 18-inch drum	1.75	R134—34-inch for 30-inch drum	3.25
R222—22-inch for 18-inch drum	2.75			R136—36-inch for 32-inch drum	3.50
				R138—38-inch for 34-inch drum	4.00
				R140—40-inch for 36-inch drum	4.50

Prices on Drum Heads are subject to frequent changes, as the cost of raw material fluctuates. In the event of an increase, we shall continue to fill orders at the prices quoted if it is possible to do so. If prices are reduced, our customers will receive immediate advantage of it.

Postage on Drum Heads

12, 13 and 14-inch sizes	3 cts.	18, 19, 20, 21, 22, 28, 30, 32, 34 and 36-inch sizes	take 1-lb. rate.
16-inch size	4 cts.	38- and 40-inch sizes	are not mailable.

DRUM FURNISHINGS

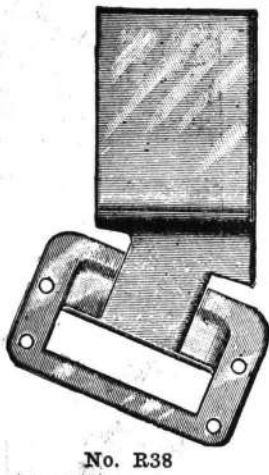

No. R38



No. R53



No. R55

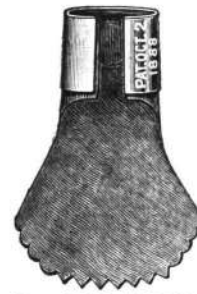

Nos. R52-R52 1/2

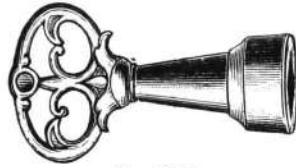

No. R63



No. R64

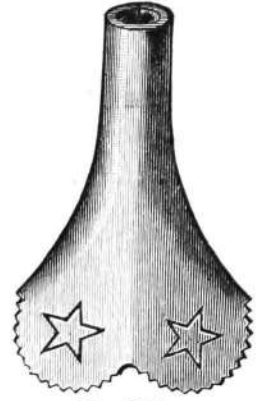

No. R51

No.	CORD HOOKS	Per doz.	Postage
R53	Malleable iron, white metal plated, for snare or bass drums.....	\$0.20	1-lb. rate
R55	Pressed steel roller hook, extra strong and durable. Lies flat over strainer hoop. Very neat in appearance. For snare or bass drums.....	1.25	1-lb. rate

No.	BELT HOOKS	Each	Postage
R36	Nickel-plated wire hook, as used on U. S. Army Drum No. R27 (see page 76).....	\$0.15	2 cts.
R38	Nickel plated. The most practical Belt Hook made. No swinging when walking; makes the drum hug the player. Used on sling or belt. Drum inclined for right or left hand drummers by reversing tongue of the hook in its socket.....	.60	1-lb. rate

No.	BRACES	Per doz.	Postage
R51	Leather, russet, stamped, for snare drum.....	\$0.55	4 cts.
R52	Leather, Patent Adjustable Brace, removable at will, for snare drum.....	1.20	1-lb. rate
R52 1/2	Leather, Patent Adjustable Brace, removable at will, for bass drum.....	1.75	1-lb. rate

No.	BELL OR CYMBAL	Each	Postage
R3	Nickel plated, with fittings.....	\$1.00	1-lb. rate

No.	KEYS	Each	Postage	No.	HOOPS	Each	Postage
R63	Nickel plated, square hole.....	\$0.10	2 cts.	R1	Snare Drum Strainer Hoops, unfinished.....	\$0.40	1 lb. rate
R64	Nickel-plated Slot Key.....	.10	2 cts.	R2	Snare Drum Flesh Hoops, unfinished.....	.15	1-lb. rate
R65	Nickel-plated Key, for rods of Drums Nos. R85 and R87.....	.15	2 cts.	R3	Bass Drum Strainer Hoops, unfinished.....	.60	not
				R4	Bass Drum Flesh Hoops, unfinished.....	.25	mailable

No.	KNEE REST	Each	Postage
R61	Nickel plated, "New Departure," very practical.....	\$0.75	1-lb. rate



Nos. R65-R67

RODS



Nos. R68-R70

No.	Each	Postage	No.	Each	Postage		
R65	6-inch Rods with hooks, white metal plated.....	\$0.20	2 cts.	R71	14-inch Thumb Screw Rods, nickel plated, bass drum.....	\$0.70	1-lb. rate
R66	8-inch Rods with hooks, white metal plated.....	.20	4 cts.	R72	16-inch Thumb Screw Rods, nickel plated, bass drum.....	.75	1-lb. rate
R67	12-inch Rods with hooks, white metal plated.....	.30	4 cts.	R73	4-inch Thumb Screw Rods, nickel plated, single action, for Professional "Victor" Single Head Drum.....	.60	2 cts.
R68	4-inch Thumb Screw Rods, nickel plated, snare drum.....	.45	3 cts.				
R69	6-inch Thumb Screw Rods, nickel plated, snare drum.....	.55	3 cts.				
R70	8-inch Thumb Screw Rods, nickel plated, snare drum.....	.60	4 cts.				
R70 1/2	12-inch Thumb Screw Rods, nickel plated, for deep regimental snare drum or bass drum.....	.65	4 cts.				

NOTE—All our Thumb Screw Rods are of Victor make and manufactured of first quality gun steel; the workmanship the best that skilled labor can produce. They have a long take-up and work smoothly and perfectly at every point of the thread. Immeasurably superior to the many cheap similar types of rods.

SNARES

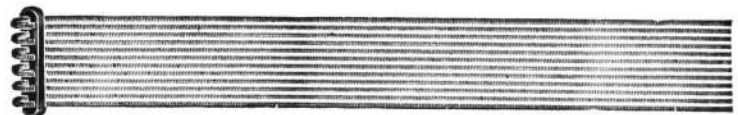

No. R81

No.	Each	Postage	No.	Per set	Postage		
R78	Gut, small gauge, in coils of 15 feet, No. 13 gauge.....	\$0.50	1 ct.	R81	Spun Steel Wire, in tight coils, will not stretch, produce very sharp tone, in sets of 12, for 16-inch drum....	1.00	3 cts.
R79	Gut, medium gauge, in coils of 15 feet, No. 11 gauge.....	.65	2 cts.	R82	Spun silver-plated steel, flexible, pulled coils, non-rust, very snappy and brilliant. In sets of 12 for 16-in. drum.....	1.25	4 cts.
R80	Gut, large gauge, in coils of 15 feet, No. 9 gauge.....	1.00	2 cts.	R83	Finest quality gut, mounted in sets of 10, for 16-inch drum.....	.60	2 cts.
				R90	Waterproof, red, woven, best quality, do not become fuzzy, in sets of 12, for 16-inch drum.....	.65	1 ct

DRUM FURNISHINGS

SNARE STRAINERS

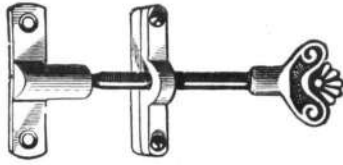

No.	Each	Postage
R83 —Nickel plated, long pattern, 6 inches.....	\$0.40	4 cts.
R83½—Nickel plated, long pattern, 8 inches.....	.40	4 cts.
R85 —Nickel plated, long pattern, 12 inches, for Corps Drums55	4 cts.
R86 —Nickel-plated Combination Strainer and Muffler. Handy throw-off for muffled and tom tom effects.	1.25	4 cts.

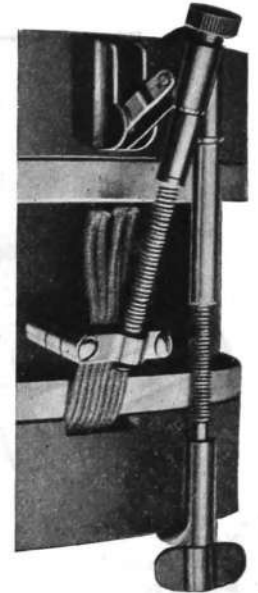

SPURS FOR BASS DRUM



No. R1

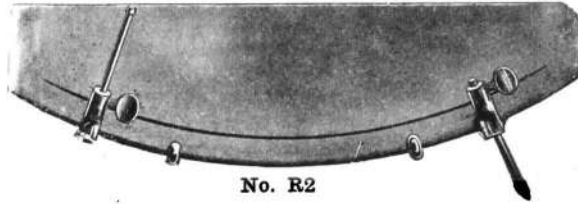

No. R2

No.	Per pair	Postage
R1—Steel pointed, oxidized copper finish.....	\$0.75	1-lb. rate
R2—Nickel-plated steel, disappearing, always stay on the drum, adjustable to any floor, never get lost; rigid, reliable; best Spur made	1.50	1-lb. rate

SNARE DRUM STICKS



No. R87



No. R97

No.	Per pair	Postage
R84 —Rosewood, polished, 14-inch, boy's size	\$0.35	4 cts.
R85 —Rosewood, polished, 16½-inch, 1¼-inch in diameter.....	.50	1-lb. rate
R86 —Ebony, polished, 16½-inch, 1¼-inch in diameter.....	.75	1-lb. rate
R87 —Ebony, polished, 16½-inch, 1¼-inch in diameter, nickel-plated ferrules	1.25	1-lb. rate
R96½—Snakewood, finest French polish, 16½-inch, 1¼-inch in diameter, nickel-plated ferrules, a fine heavy Stick for corps drum work	2.25	1-lb. rate
R92 —Rosewood, finest French polish, 16½-inch, ½-inch in diameter75	1-lb. rate
R93 —Rosewood, finest French polish, 15½-inch, ½-inch in diameter75	1-lb. rate
R94 —Ebony, finest French polish, 17 -inch, ⅝-inch in diameter.....	1.00	1-lb. rate
R95 —Ebony, finest French polish, 15½-inch, ⅝-inch in diameter.....	1.00	1-lb. rate
R96 —Snakewood, finest French polish, 17-inch, ½-inch in diameter	1.75	1-lb. rate
R97 —Snakewood, finest French polish, 15-inch, ½-inch in diameter	1.75	1-lb. rate
R98 —Leopard Snakewood, finest French polish, 15-inch, ½-inch in diameter	2.50	1-lb. rate
R99 —Hickory, polished, 16½-inch, 1¼-inch in diameter.....	.50	1-lb. rate
R99½—Hickory, polished, 15½-inch, ⅝-inch in diameter, for orchestra use50	1-lb. rate

Professional Models for Orchestra Use

BASS DRUM STICKS



No. R88



No. R88½

No.	Each	Postage
R88 —Hickory handle, with chamois skin covered head.....	\$0.50	1-lb. rate
R88½—Rosewood handle, felt head screwed on, evenly balanced.....	1.50	1-lb. rate

THE SILENT DRUM (PRACTICE PAD)

Gives same rebound as Snare Drum but absolutely noiseless. A valuable aid to students desiring to practice without annoying others. A necessity to all drum teachers.

No.	Each
R139—Padded calfskin head, with metal rim on wood base.....	\$1.25



DRUMMERS' TRAPS OR IMITATIONS

OF THE CELEBRATED "PERFECTION," "LEEDY" AND "DUPLIX" MAKES

We call the attention of professional trap drummers to these "traps" or imitations. They are absolutely the best on the market. No toys among them, but all substantial, practical articles, right down to date and embodying all the latest ideas that have proven successful.

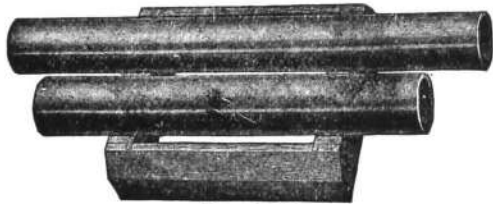

No. R103

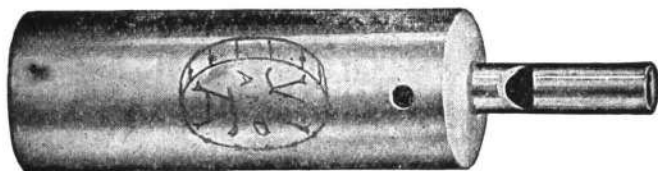

Open

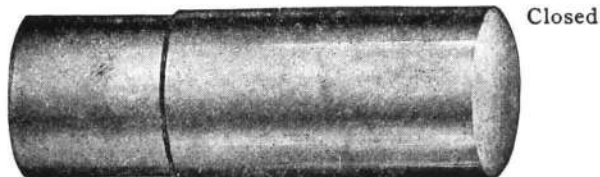

Closed

No. R105



No. R129



No. R131

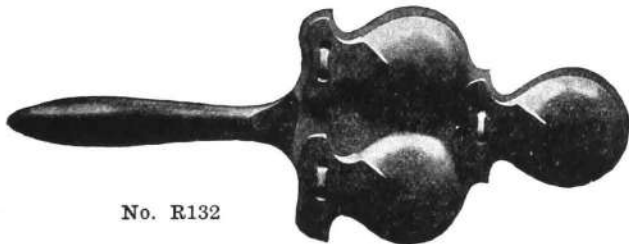

No. R132

PERFECTION SANITARY IMITATIONS

Made of metal tubes, nickel plated, exact imitations, and absolutely clean and sanitary at all times, being protected by a metal cap which renders them impervious to dust, grease, salivary deposits and various other accumulations liable to cause infection. Guaranteed to last forever.

No.	Each	Postage
R107—Cow Bawl or Moo.....	\$1.25	1-lb. rate
R109—Baby Cry	1.00	4 cts.
R111—Bantam Rooster	1.00	4 cts.
R113—Shanghai Rooster	1.00	4 cts.
R115—Dunghill Rooster	1.00	4 cts.
R117—Bob White	1.25	4 cts.
R119—Peacock	1.00	4 cts.
R121—Jaybird	1.00	4 cts.
R123—Hen Cackle	1.00	4 cts.

ANVILS

No.	Each
R101—Anvil. A perfect imitation of the anvil or striking upon steel. Perfection make	\$1.50
R103—Anvil. Special steel tubing, 1 3/8 inches in diameter, full nickel, on hard wood frame, Perfection make.....	3.00

BIRD WHISTLES

No.	Each
R105—Perfection Bird Whistle. Always ready for use. Can be placed in any position without the cap on and water will not leak out. With cap on it can be carried in pocket and it is absolutely impossible for it to leak. Far the best bird whistle made. Must be seen to be appreciated. Finished in full nickel. (Postage, 1-lb. rate)	\$1.50

No.	Each
R11—Canary Bird Whistle, Duplex make. (Postage, 2 cts).....	\$0.20
R137—Clog Mallets, with jingles. Perfection make. (Postage, 1-lb. rate)	\$1.00



No. R11

CASTANETS

Leedy Make
Large Concert Size, Ebony Mounted on Hard Ebonized Wood Handles

No.	Each	Postage
R129—One pair	\$1.75	4 cts.
R131—Two pair	2.25	1-lb. rate
R132—Three pair	2.75	1-lb. rate

See page 96 for additional Castanets.



No. R137

CUCKOOS



No.	Each	Postage
R143—Wood, cylinder shape, can be tuned in any key.	\$0.65	4 cts.
R145—Wood, square shape, very loud, can be tuned in any key. Perfection make.....	1.50	1-lb. rate

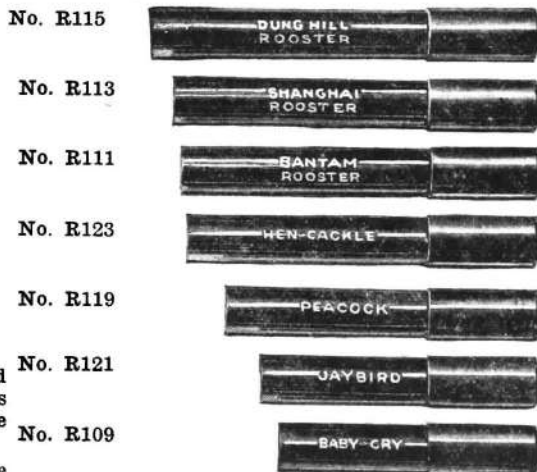

No. R107—Cow Bawl



No. R117—Bob White, with Cap Removed

DRUMMERS' TRAPS OR IMITATIONS

CYCLONE WHISTLE AND CYCLONE HORN

No.	Each	Postage
R149—The best wind whistle made; powerful and easy to blow. Can be taken apart and adjusted. Perfection make....	\$1.00	3 cts.
R197—Cyclone Horn, brass. Very powerful. The greatest of all instruments for windstorm effects.....	3.50	



No. R149

DOG BARK

No.	Each	Postage
R153—Dog Bark, Perfection make.....	\$0.90	1-lb. rate

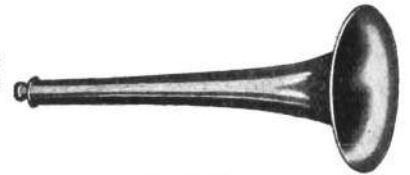

No. R197

DUCK AND CROW CALLS

No.	Each	Postage
R 6—Duck Quack—A perfect imitation. Duplex make.	\$0.90	4 cts.
R125—Olt Adjustable Duck and Crow Call. Constructed of the best hard rubber and equipped with adjustable tone slide by which the tone can be changed in a second for duck call, crow or other birds. Most natural duck and crow imitation made	1.25	4 cts.

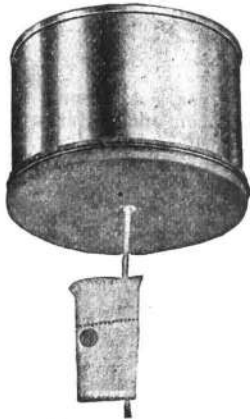

No. R153



No. R20



No. R6



No. R125

FROGS AND TOADS

No.	Each	Postage
R20—Toad, Duplex make.....	\$0.75	4 cts.
R46—Pond Frog, Duplex make.....	.90	1-lb. rate



No. R46

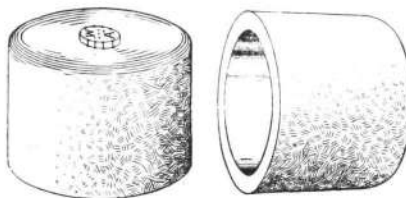

No. R167

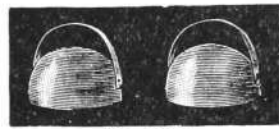

No. R34

HORSE HOOF IMITATIONS

No.	Per pair	Postage
R 34—Hard wood or cocoanut, with straps.....	\$1.10	1-lb. rate
R167—Hard wood, Perfection make.....	.60	1-lb. rate

INDIAN DRUM

No.	Each
R173—Indian Drum or Tom-Tom, Perfection make, without beater	\$2.50

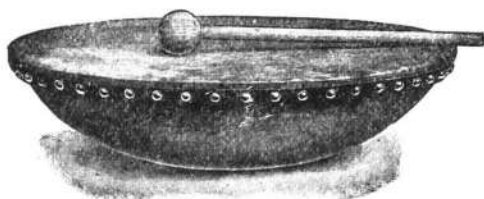

No. R173

LOCOMOTIVE BELL

No.	Each
R135—Nickel-plated tube, complete with fixture and hammer; a correct imitation. Perfection make.....	\$3.25

BELL PLATE

No.	Each
R133—Bell Plate, Perfection make. Single hammer gives correct imitation of church or fire bell; double hammer gives imitation of police patrol, fire engine or ambulance gongs	\$2.00

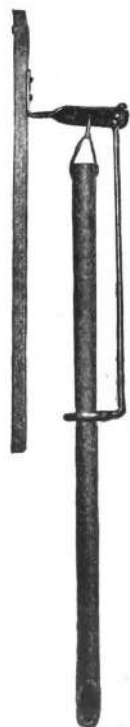

No. R135

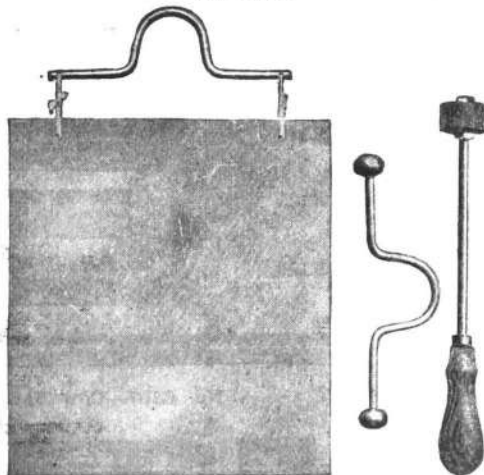

No. R133

LOCUST

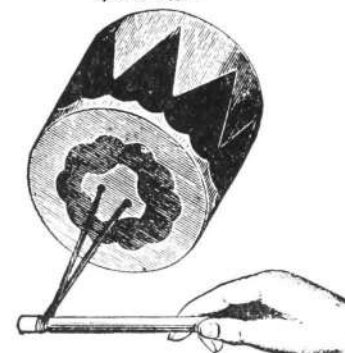

No. R161

No.	Each
R161—Locust or Frog Imitation; Duplex make. (Postage, 1-lb. rate)	\$1.00

DRUMMERS' TRAPS OR IMITATIONS



No. R183

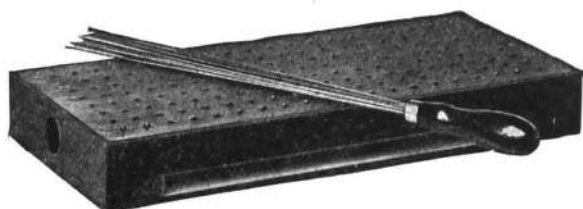

No. R185

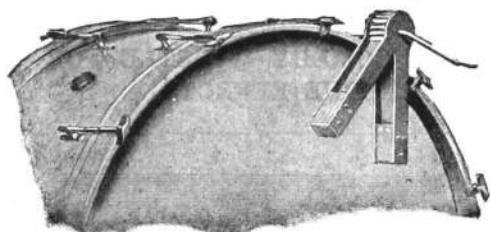

No. R182—Rattle Clamped to Drum Rim

POLICE RATTLE



Very strong and durable, all parts fastened with screws. Swings both ways, makes more noise than any other rattle.

No. R181—Police Rattle, Perfection make. (Postage, 1-lb rate)\$1.25

SLAPSTICK OR WHIP

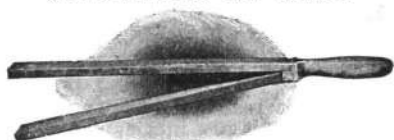

No. R187—Whip or Slapstick, to work with one hand; cracks like a pistol; very durable. Made of hardwood, nicely finished. Perfection make.....\$0.60

SQUAWKER AND SQUAWKER HOLDER

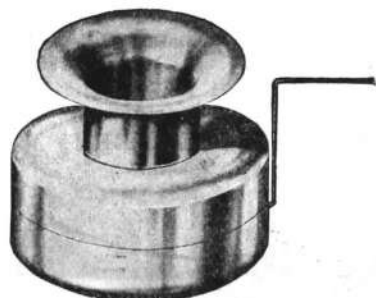

No. R 141



No. R 23
Each Postage

No. R141—Squawker, a noise maker. Imitates locust, frog, cricket, woodpecker, etc. Indispensable to every trap drummer.. \$0.15 1-lb. rate
R 23—Squawker Holder, nickel plated. Glamps to drum hoop. Perfection make..... .65 1-lb. rate

POPGUN

No. R183—Self-loading Popgun, sure fire every time. Absolutely impossible to break the cork, a feature found in no other Popgun. Perfection make\$2.25

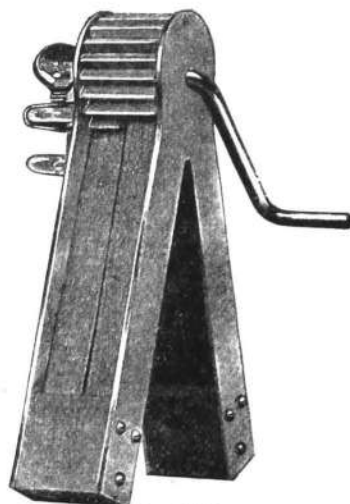

No. R182

RAILROAD TRAIN

No. R185—Imitates every sound ever made by a railroad engine. Operated with one hand, leaving the other free to use bell and whistle. Perfection make..... \$2.00

RATTLE

No. R182—Perfection Rattle. Made of pressed steel and rock maple. Four tongues, all working independently and striking at different intervals. Produces a perfect roll. Guaranteed to last a lifetime. Indispensable to the drummer who plays for pictures or vaudeville.....\$2.50

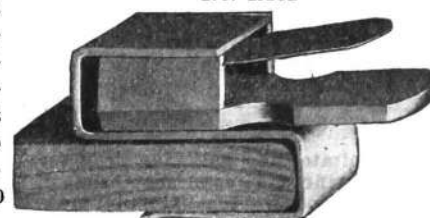

TELEGRAPH IMITATION

No. R127—Telegraph, Typewriter and Clock Tick Imitation, with holder. Fits any drum hoop. Perfection make. Complete.... \$0.35 3 cts.
R127½—Imitation alone, without holder..... .10 2 cts.

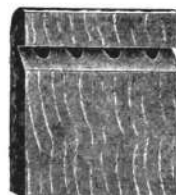

No. R26

ROBIN

No. R26—Robin, Duplex make \$1.00 3 cts.

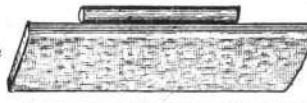

SAND JIG

No. R16—Sand Jig Imitator \$0.60 1-lb. rate

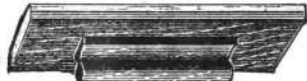

No. R16

SLEIGH BELLS

No. R189—Sleigh Bells, one dozen on strap.....\$2.00
R191—Sleigh Bells, two dozen on strap..... 3.00
R 24—Sleigh Bells, two rows on handle, Duplex make 2.00
R 33—Sleigh Bells, four rows on handle, Duplex make 3.25

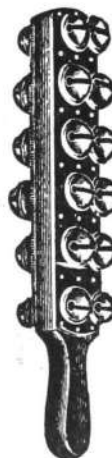

No. R33



No. R24

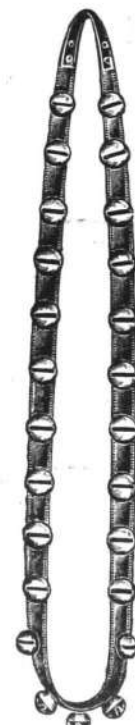

No. R189

DRUMMERS' TRAPS OR IMITATIONS

EFFECTS THAT ARE INDISPENSABLE TO THE MOVING PICTURE HOUSE DRUMMER

RAIN AND SURF EFFECT

An imitation that every picture show drummer must have. Properly handled, it gives a rain imitation and surf effect that cannot be surpassed. Made entirely of metal, nothing to wear out.

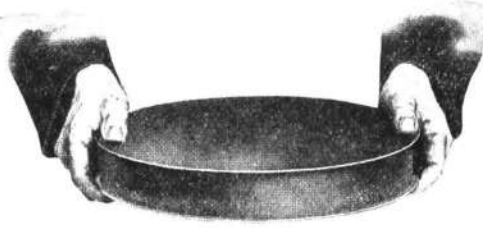

No. Each
R160—Rain, surf and wave effect.....\$3.00

PERFECTION COMBINATION SLAP PAD AND SAND BOARD

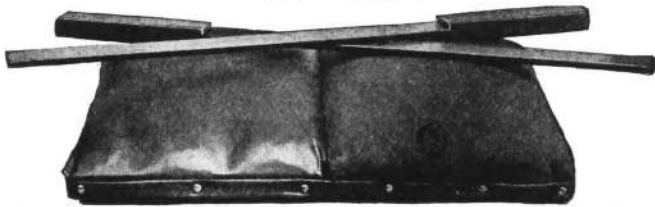

Imitates the galloping of horses on the sod or on hard pavement, rifle and pistol shots, slap in the face, etc., also surf effects and all others that are obtained with a sand board. Another trap that is indispensable in the picture business. Very substantially made. Combination pad, half canvas, half leather, on hardwood base.

No. Each
R168—Perfection Combination Slap Pad.....\$3.00
Parcel Post Shipping Weight, 5 lbs.

LION ROAR AND BEAR GROWL

This effective trap has become very popular for all jungle scenes in moving picture or descriptive work. Very powerful and durable, always ready for use, convenient to handle and pack

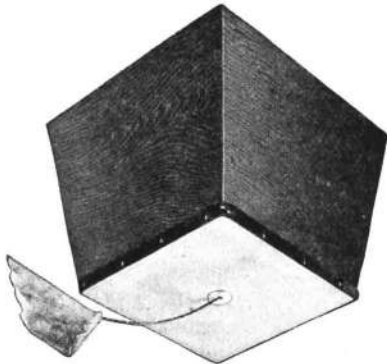

No. Each
R154—Lion Roar and Bear Growl.....\$2.25
Parcel Post Shipping Weight, 3 lbs.

COW BELL

No. Each
R188—About 5¼ inches high.....\$0.60
Parcel Post Shipping Weight, 2 lbs.



LUDWIG MOTOR CHUG IMITATION

This machine imitates the chug of a motor boat, cycle or automobile perfectly by simply turning a handle. Distant approaches can be accurately gauged by raising or lowering the small knob at the top. Durable and simple inside mechanism. Well finished oak case.

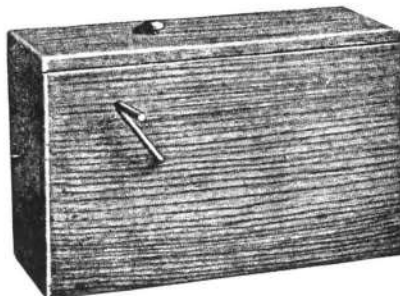

No. Each
R155—Ludwig Motor Chug Imitation.....\$3.00
Parcel Post Shipping Weight, 7 lbs.

COMBINATION RAILROAD WHISTLE AND CUCKOO



This is a valuable trap for various effects. Has a range of a full octave and is voiced to respond with equal strength to high or low notes. Imitates railroad whistles, air brake and cuckoo; can also be used for comedy effects. Heavily nickel plated brass tubing with leather non-corroding plunger; 8½ inches long, ¾ inch in diameter.

No. Each
R159—Metal slide whistle\$1.25
Parcel Post Shipping Weight, 1 lb.

PERFECTION COMEDY WHISTLE FOR BURLESQUE EFFECTS



An efficient wood whistle for comedy work at a low price; 15 inches long, 1¾ inches square. Has a range of one octave.

No. Each
R198—Perfection wooden comedy whistle.....\$1.25

AUTOMOBILE HORN

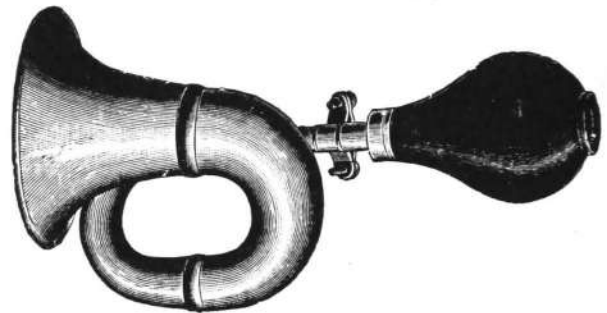

Not an imitation but a real horn just as used on automobiles. Gives a powerful honk. Heavily nickel plated.

No. Each
R156—Automobile Horn, bell 5 inches, length with rubber bulb, 13 inches\$3.00
Parcel Post Shipping Weight, 2 lbs.

AUTOMOBILE CHUG

No. Each
R158—Made of tin, filled with shot. Properly handled, gives very good imitation\$0.50
Parcel Post Shipping Weight, 1 lb.

SIGNAL HORN OR MOTORCYCLE SIREN

Two tones, nickel plated, 15 inches long, bulb included. Very powerful whistle for motorcycles, imitation of suburban electric train siren or motor boat.



No. Each
R157—Signal horn or motorcycle siren.....\$2.50
Parcel Post Shipping Weight, 2 lbs.

DRUMMERS' TRAPS OR IMITATIONS

WHISTLES



No. R14



No. R193



No. R27



No. R2



No. R194

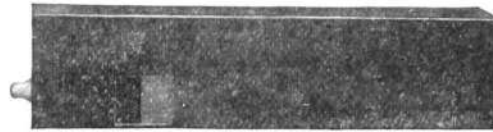

No. R195



No. R199

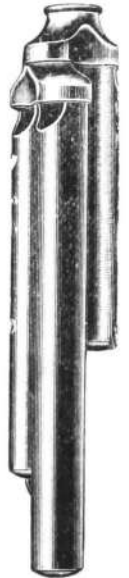

No. R196

No.	Each	Postage
R 2—Police Whistle, very loud, Duplex make.....	\$0.60	2 cts.
R196—Locomotive Whistle, nickel plated, 3 tones, loud and piercing75	4 cts.
R 27—Tugboat Whistle, 3 Japanned tin pipes, Duplex make.....	1.50	
R 14—Steamboat Whistle, 3 Japanned tin pipes, Duplex make.....	1.75	
R193—Locomotive Whistle, 3 tones, wood, Perfection make.....	2.25	
R194—Locomotive Whistle, 2 tones, wood, Perfection make.....	2.00	
R195—Steamboat Whistle, 1 very deep tone, Perfection make.....	2.00	
R199—Deagan Musical Push Pipe. Has a range of an octave and a half. Tone similar to a steamboat whistle. Just the thing for musical burlesque and a very handy drummer's trap	4.50	

CHINESE INSTRUMENTS

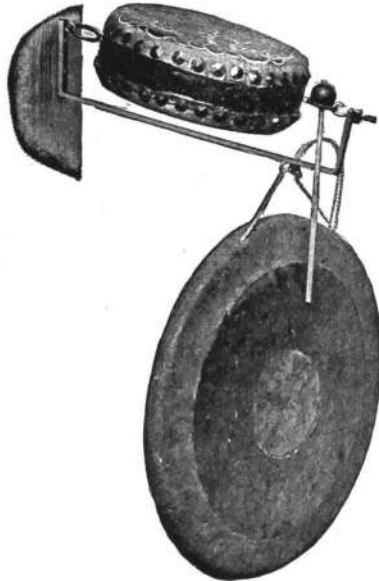

Nos. R175—R176



No. R177



No. R24

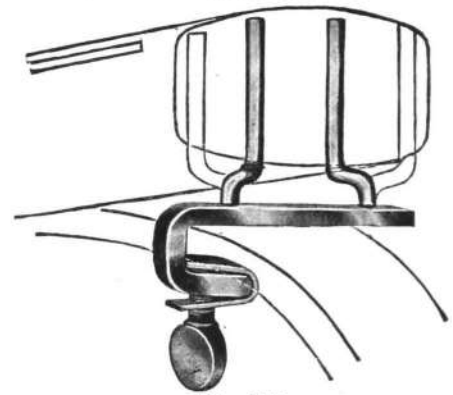

No. R22

No. R21

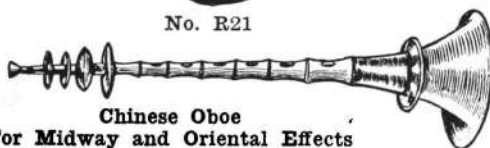

Chinese Oboe

For Midway and Oriental Effects

No.	Each
R175—Chinese Wood Drum, made from a solid block of ebony or teakwood, slotted. Produces powerful click. Very effective when used alternately with the tom tom. Can also be used for clogs or horsehoofs. Small size 2 3/4 x 6 3/4, for orchestra use	\$0.60
R176—Same, large size, 3 1/4 x 8 3/4, for band use.....	1.50
R177—Chinese Drum, skin, decorated top, 9 inches in diameter. Very effective on account of its peculiarity of tone.....	1.50
R 21—Chinese Tom Tom and Gong Holder. Nickel plated. For theatre orchestra drummers. Perfection make.....	1.25
R 22—Chinese Wood Block Holder. Nickel plated. Clamp fits any drum hoop. Perfection make.....	1.00
R 24—Chinese Wood Block and Squawker Holder. Nickel plated. Fits any drum hoop. Perfection make.....	1.25
R179—Chinese Oboe, small size, 12 inches long, including two reeds50
R180—Chinese Oboe, large size, 16 inches long, including two reeds75
R 1—Chinese Oboe Reeds30

See page 6 for shipping weights.

CYMBALS AND TRIANGLES

Single Cymbals at one-half the following prices

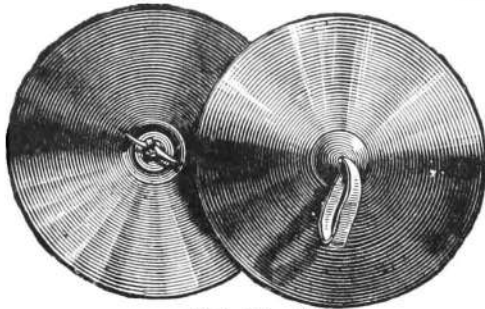

Nos. R1—R4

AMERICAN MAKE

No.		Per pair
R1	— 7-inch, brass, leather handles.....	\$1.00
R2	— 8-inch, brass, leather handles.....	1.25
R2½	— 10-inch, brass, leather handles.....	2.00
R3	— 12-inch, brass, leather handles.....	2.75
R4	— 13-inch, brass, leather handles.....	3.25

TURKISH (American Made)

No.		Per pair
R5	— 12-inch, composition metal, leather handles, fine tone.....	\$7.50
R6	— 13-inch, composition metal, leather handles, fine tone.....	9.00

GENUINE PERSIAN (Turkish Process)

No.		Per pair
R50	— 12-inch, hand hammered, finest quality, superb tone.....	\$12.50
R60	— 13-inch, hand hammered, finest quality, superb tone.....	15.00

GENUINE TURKISH, ZILDJIAN & CIE. MADE IN CONSTANTINOPLE

World renowned for centuries, matchless in euphonical beauty, sonority and power of sound, have been made since 1684, exclusively by members of one family, according to a strictly-guarded secret.

As signs of their genuineness, every Cymbal bears the following trade-marks:

On the outside, this stamp:



K. ZILDJIAN & C^o
CONSTANTINOPLE

No.		Per pair
R 8	— About 12 inches, with leather handles.....	\$20.00
R10	— About 14 inches, with leather handles.....	25.00
R12	— About 15 inches, with leather handles.....	27.50

And inside the shell, written by hand, their Armenian signature, as below:

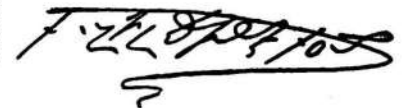

CHINESE CYMBALS—GENUINE

Finest quality, pure gong metal, hammered very thin. For crashes; particularly effective in rendering any character of Oriental music.

No.		Per pair
R11	— 10-inch	\$ 2.75
R13	— 12-inch	3.50
R15	— 13-inch	4.25
R17	— 15-inch	5.50
R19	— 18-inch	7.50
R21	— 20-inch	12.00
R23	— 21-inch	14.00

Single ones at half the above prices.

CHINESE GONGS—GENUINE

Made from pure brass gong metal. Give a soft, vibrating tone. Indispensable to the theatre orchestra drummer.

No.	(Beater included.)	Each
R35	— 18-inch	\$5.00
R37	— 20-inch	7.50
R39	— 23-inch	9.00

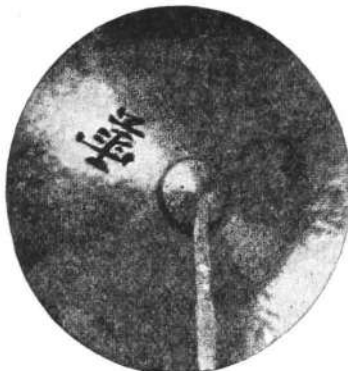

Nos. R11—R23
Chinese Cymbals—Genuine



Nos. R35—R39
Chinese Gong—Genuine

CYMBAL SACK

No.		Each
R8	— Heavy, black smooth leather, hand sewed and welted, with flap and shoulder strap, nicely embossed, nickel polished trimmings; for cymbals up to 13 inches	\$3.00



TRIANGLES

Heavy steel, nickel plated, best quality American make. Hammer included

No.		Each	Postage
R 4	— 4-inch	\$0.25	1-lb. rate
R 6	— 6-inch35	1-lb. rate
R 7	— 7-inch45	1-lb. rate
R 8	— 8-inch50	1-lb. rate
R10	— 10-inch75	2-lb. rate



FINE PROFESSIONAL TRIANGLE FOR TRAP DRUMMERS

No.		Each
R80	— 8-inch, extra heavy, special grade steel, nickel plated, with steel beater, Leedy make, beautiful tone. (Postage, 2-lb. rate)	\$1.50

See page 6 for shipping weights of Cymbals.

HAND CYMBAL BEATER

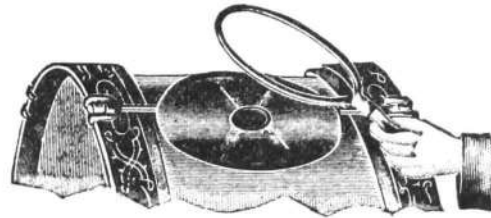

No.	Each	Postage
R4—Heavy Wire Circle, with wood handle.....	\$0.60	1-lb. rate

CYMBAL AND TRIANGLE HOLDERS

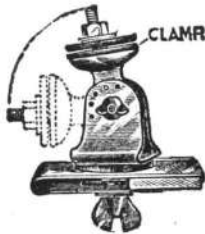

No. R12—Burt's Patent



No. R14—'Victor' Cymbal Holder

SIMPLICITY CRASH CYMBAL HOLDER

Suspends the cymbal over the bass drum where it is most convenient for use. Universally adjustable to any height or position. The clamp is rigid and does not mar the hoop. Will hold any size cymbals from 10 to 21 inches. Folds compactly for packing. Especially built for lightness and strength.

No. R15—Simplicity Crash Cymbal Holder

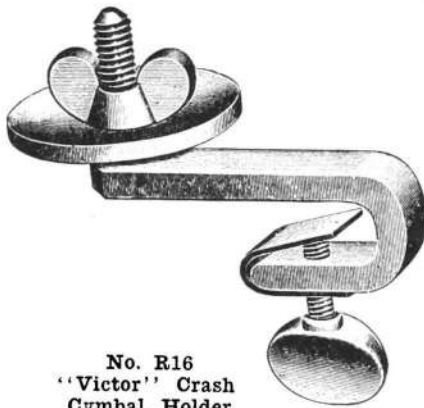
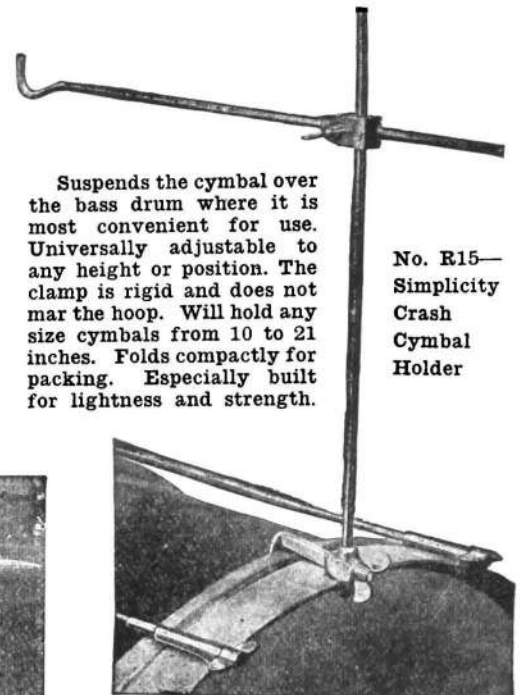

No. R16
'Victor' Crash Cymbal Holder

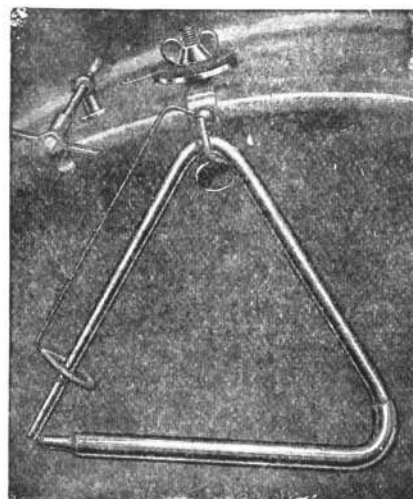

No. R18

'Victor' Crash Cymbal and Triangle Holder

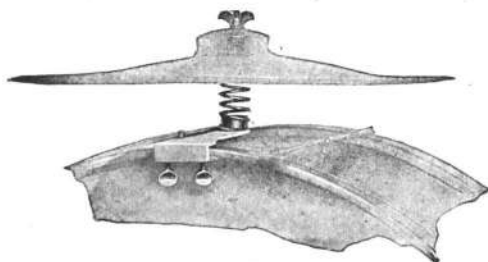

No. R19—Perfection Crash Cymbal Holder

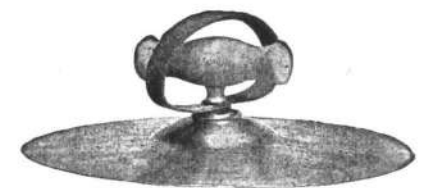

No. R20—Hand Cymbal Holder

No.	Each	Postage
R12—Cymbal Holder, Burt's patent. Attached to drum hoop by clamp. Perfectly solid. Can be used at any angle on the top of the drum, or by means of a clever device can be lowered so the player can use a side stroke; or for pedal use.....	\$1.50	1-lb. rate
R14—'Victor' Cymbal Holder, nickel plated; with double patent clamps	1.00	1-lb. rate
R16—'Victor' Crash Cymbal Holder, full nickel plate	1.25	1-lb. rate
R15—'Simplicity' Crash Cymbal Holder	1.60	1-lb. rate
R18—'Victor' Combination Crash Cymbal and Triangle Holder. Full nickel. The picture tells the story perfectly. Without triangle.....	1.50	1-lb. rate
R19—'Perfection' Crash Cymbal Holder. The best Cymbal Holder on the market. Allows all the vibrations of the cymbal and brings it into position for the next crash	2.25	2-lb. rate
R20—Hand Cymbal Holder. Perfect grip for hand with adjustable strap, which makes it impossible to drop the cymbal	1.25	1-lb. rate

TAMBOURINES, CASTANETS AND BONES

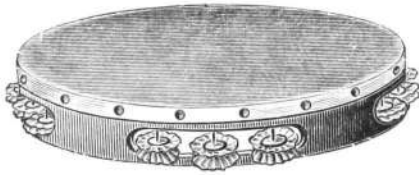

Nos. R2, R4, R5
Maple Rim—Plain

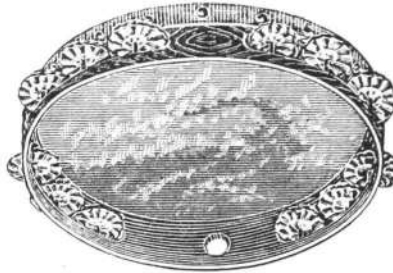

Nos. R8, R9
Maple Rim—Painted

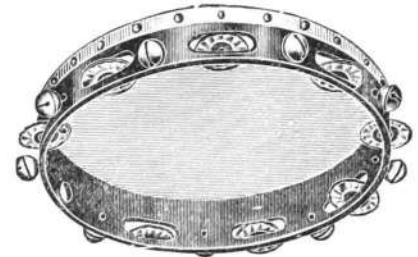

Nos. R14, R15—Maple Rim, Painted

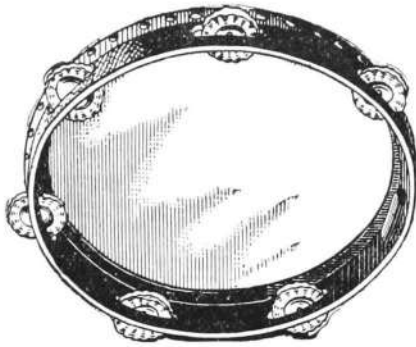

No. R910
Nickel Rim, Professional Model

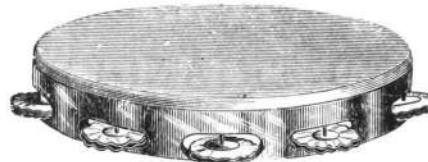

Nos. R10, R11—Nickel Rim



Nos. R514, R528
Salvation Army Model



No. R912—Professional

No.	Each	Postage
R 2—7-inch sheepskin, tack head, maple rim, plain, 6 sets jingles	\$0.35	1-lb. rate
R 4—8-inch sheepskin, tack head, maple rim, plain, 9 sets jingles	.50	1-lb. rate
R 5—10-inch sheepskin, tack head, maple rim, plain, 9 sets jingles	.60	1-lb. rate
R 8—8-inch calfskin, tack head, painted maple rim, 9 sets jingles	.65	1-lb. rate
R 9—10-inch calfskin, tack head, painted maple rim, 12 sets jingles	1.00	1-lb. rate
R 10—8-inch calfskin, tack head, nickel rim, 8 sets jingles	.90	1-lb. rate
R 11—10-inch calfskin, tack head, nickel rim, 8 sets jingles	1.50	1-lb. rate
R 14—8-inch calfskin, tack head, painted maple rim, 11 sets jingles and bells	1.25	1-lb. rate
R 15—10-inch calfskin, tack head, painted maple rim, 17 sets jingles and bells	1.75	1-lb. rate
R514—10-inch calfskin, tack head, 14 sets jingles	1.50	1-lb. rate
R528—10-inch calfskin, tack head, 28 sets jingles	2.25	2-lb. rate

FINE PROFESSIONAL TAMBOURINES FOR TRAP DRUMMERS

No.	Each
R910—10-inch calfskin, tack head, nickel-plated rim, professional, 1 3/4 inches total height of rim, 7 sets German silver jingles, inside hand-hold. (Postage, 1-lb. rate)	\$2.00
R912—10-inch hard maple rim, finished in dark rosewood. Finest professional orchestra tambourine. Rim 1 3/4 inches high. Best quality calf head, waterproofed, 12 sets heavy German silver jingles, rim reinforced by inner hoop, inside hand-hold. (Postage, 2-lb. rate)	2.75

CASTANETS

No.	Per set of 4	Postage
R50—Boxwood, small size	\$0.40	4 cts.
R55—Boxwood, large size	.50	4 cts.
R52—Ebony, small size	.65	4 cts.
R57—Ebony, large size	.75	1-lb. rate

Also see page 89 for "Leedy" make Professional Castanets



Nos. R6—R14

BONES AND CLAPPERS

No.	Per set of 4	Postage
R 6—Rosewood, 5 1/2 inches	\$0.20	1-lb. rate
R 7—Rosewood, 7 inches extra quality, fine model	.30	1-lb. rate
R10—Ebony, 5 1/2 inches	.40	1-lb. rate
R12—Ebony, 7 inches, extra quality, fine model	.60	1-lb. rate
R14—Ebony, 7 inches, finely polished, professional	.80	1-lb. rate

PATENT CLAPPERS

No.	Per pair	Postage
R13—Maple, steel and lead clappers on both sides	\$0.10	4 cts.

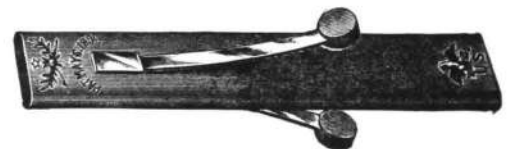

No. R13



Nos. R50—R57

TUBEPHONES AND XYLOPHONES

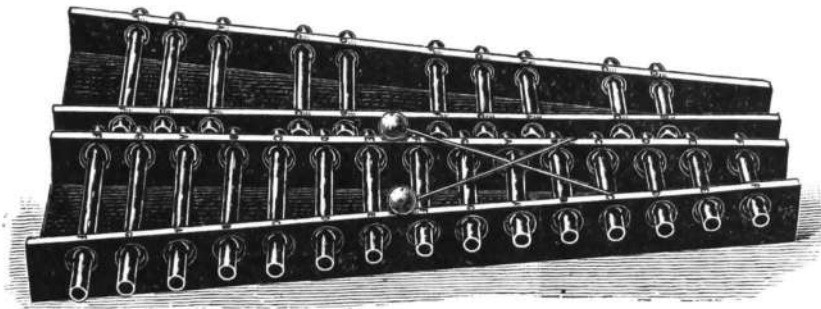

No. R4

TUBEPHONES

- | No. | Each |
|---|---------|
| R2—15 polished brass tubes on frame, 2 octaves, G to G, no semitones. Tubes ½ inch in diameter. Pair mallets included | \$ 1.75 |
| R4—25 polished brass tubes on frames, 2 octaves, A to A, full chromatic. Tubes ⅝ inch in diameter. Pair mallets included | 5.00 |
| R6—25 large, heavy brass tubes, finely nickel plated. Two octaves, A to A, full chromatic. Tubes ¾ inch in diameter; clear, powerful tone. In good case. Pair mallets included..... | 20.00 |

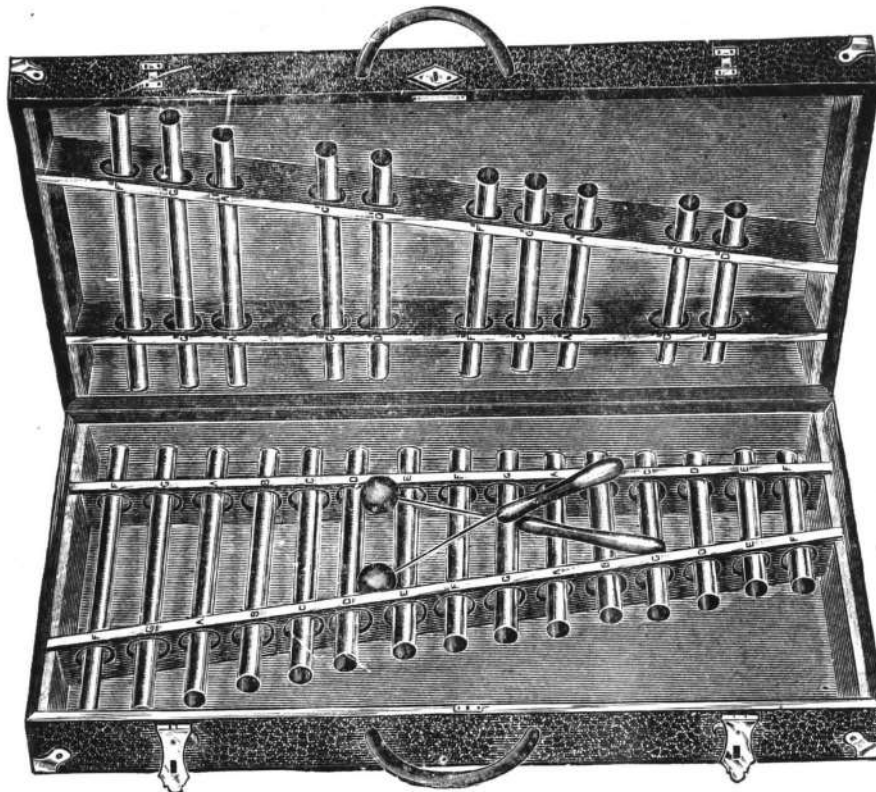

No. R6

XYLOPHONES

- | No. | Each |
|---|---------|
| R2—15 maple bars, 2 octaves, no semitones. Pair hammers included..... | \$ 1.50 |
| R5—29 maple bars, 2 octaves, full chromatic; in pasteboard box. Pair hammers included | 5.00 |
| R6—17 rosewood bars, 2 octaves, no semitones; in fine hardwood case. Pair hammers included | 15.00 |
| R7—29 rosewood bars, 2¼ octaves, full chromatic; in fine hardwood case. Pair hammers included | 20.00 |

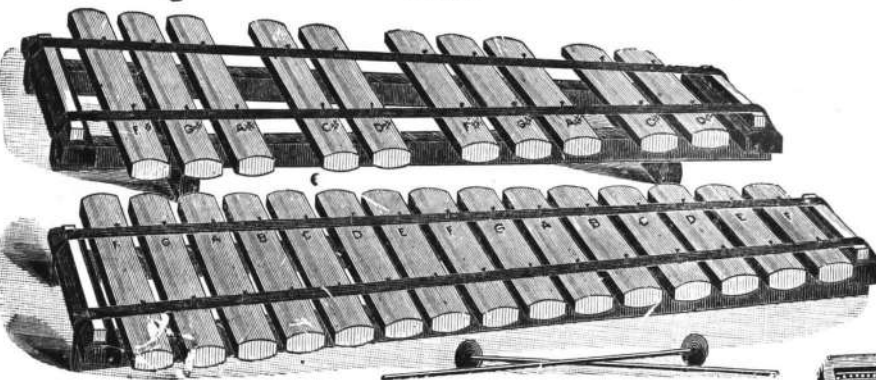

No. R5

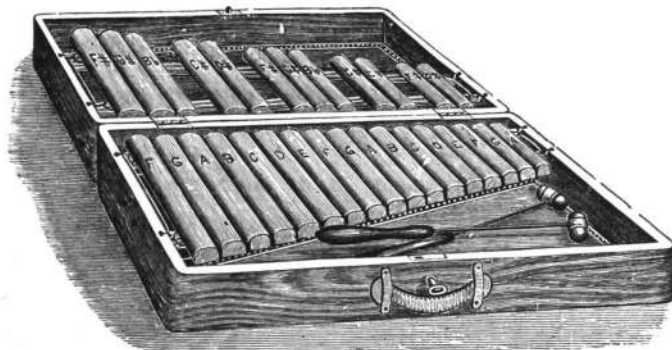

No. R7—Xylophone
Rosewood, in Fine Hardwood Case; Weight, 18 lbs.

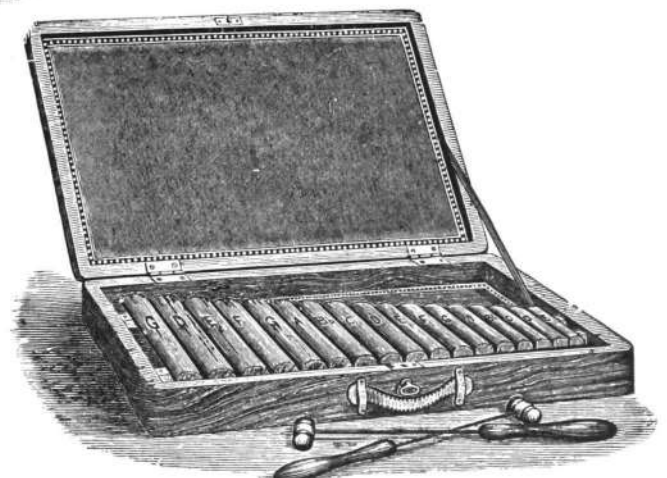

No. R6—Xylophone
Rosewood, in Fine Hardwood Case; Weight, 12 lbs.

FINE PROFESSIONAL XYLOPHONES

Manufactured by J. C. Deagan

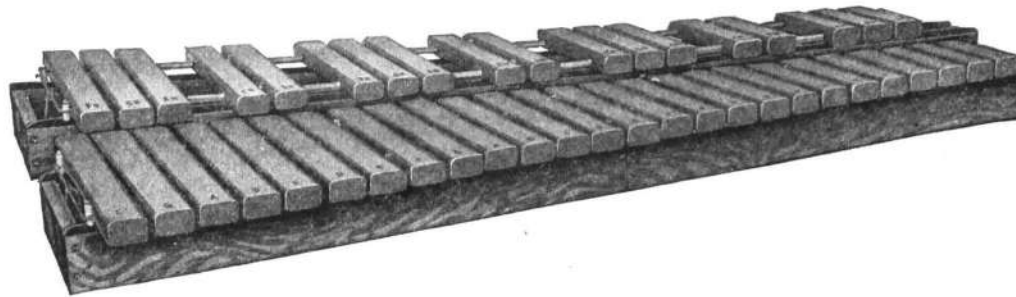

Made of the choicest, most select and thoroughly seasoned rosewood, which is recognized generally to be the best for tone. Mounted on specially designed sounding-board frames, each frame having a spruce sounding board (the same as a grand piano) which adds greatly to the tone quality of the instrument. The tuning of the Deagan Xylophones is perfection itself, while the workmanship and finish are the very best. Practically all leading artists throughout the world use Deagan Xylophones.

No.	Each
R14 —32 bars, 2½ octaves, bars 1½ x ⅞ inch; chromatic F to C, on frames, high pitch.....	\$22.00
R14½—Same as No. R14, but low pitch	22.00
R16 —37 bars, 3 octaves, bars 1½ x ⅞ inch; chromatic, C to C (deeper), on frames, high pitch.....	30.00
R16½—Same as No. R16, but low pitch.....	30.00

Prices Include 3 Pairs Assorted Mallets

Nos. R14, R14½, 38½ inches long; 24 inches wide; weight 22 lbs. Nos. R16, R16½, 42½ inches long; 27½ inches wide; weight, 24 lbs.

DEAGAN "DRUMMER'S SPECIAL" XYLOPHONE

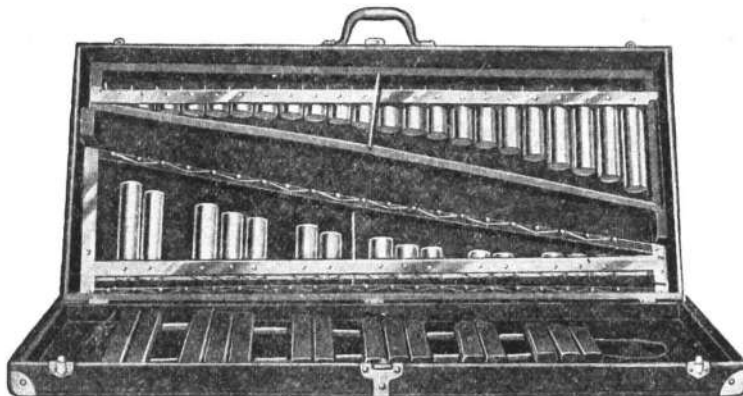

DEAGAN "DRUMMER'S SPECIAL" NAGAED XYLOPHONE
Packed in Hand Carrying Case

Note Resonators packed inside of frame, thus the entire instrument packs in the same space as a Xylophone without Resonators.

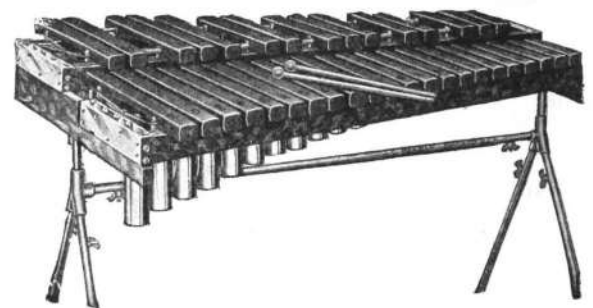

Xylophone Set Up Ready for Use
(One Minute)
Total Length of Instrument, 38 Inches

The finest little Xylophone on the market for the jobbing drummer. Of such size and weight that it can easily be transported about by hand, yet it possesses all the tonal advantages of the larger standard size instruments described on the following page. They are constructed of the very choicest Nagaed wood and so far as tone, tuning, carrying power and workmanship are concerned, are unsurpassed. The material is all specially made, combining the greatest strength with the least weight.

No.	Each
R117½—37 bars, 1¼ x ⅞ inch, with resonators, 3 octaves, chromatic C to C, Low Pitch; including floor rack, hand carrying case and five sets assorted mallets.....	\$75.00

DEAGAN PROFESSIONAL XYLOPHONES

The make used by vaudeville players and professional musicians practically to the exclusion of all others.

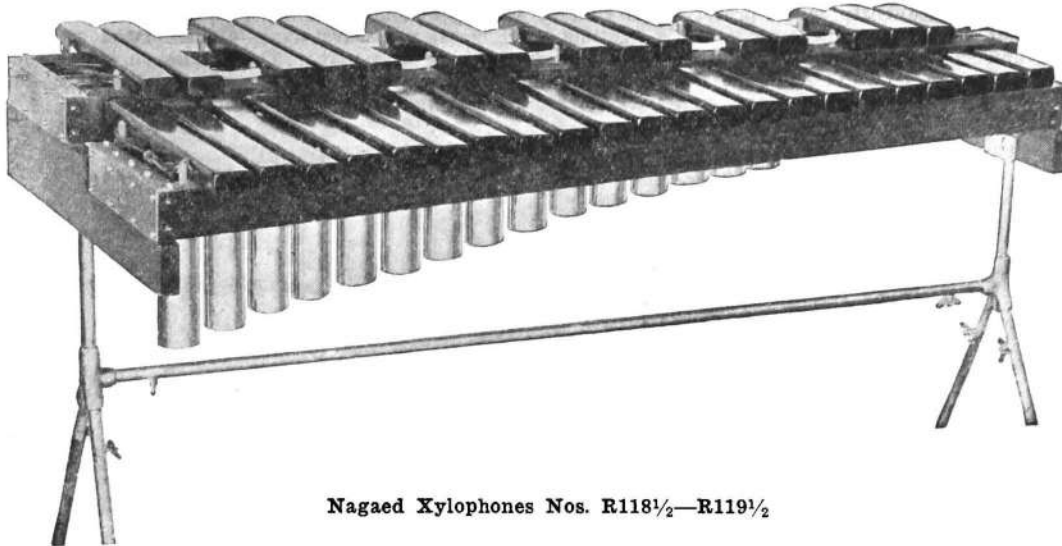

Nagaed Xylophones Nos. R118½—R119½

Constructed of thoroughly seasoned nagaed wood mounted on floor racks of triple-plated seamless steel tubing. A resonator on each bar materially increases the tone and carrying power. Six pairs assorted mallets included with each instrument.

No.	Each
R118½—37 bars, 1⅝ x 1⅜ inch; 3 octaves, chromatic, C to C Low Pitch, on floor rack.....	\$65.00
R119½—44 bars, 1⅝ x 1⅜ inch; 3½ octaves, chromatic, F to C Low Pitch, on floor rack.....	75.00
Total Length of No. R118½, 46 inches.	



Klyposerus Xylophones Nos. R120½—R121½

Constructed of klyposerus, the most durable and finest-toned wood in the world. Resonator for each bar. All Deagan Floor Racks are of slip joint type, pulling apart, without screws of any kind to get lost or out of order. Six pairs assorted mallets with each instrument.

No.	Each
R120½—44 bars, 1⅝ x ⅞ inch; 3½ octaves, chromatic F to C, Low Pitch, on floor rack.....	\$ 90.00
R121½—49 bars, 1⅝ x ⅞ inch; 4 octaves, chromatic C to C, Low Pitch, on floor rack.....	125.00
Total Length of No. R120½, 55 inches.	

The above instruments are all made especially to order. Three weeks time required.

Your old Xylophone taken in part payment if it is Low Pitch. Easy monthly payment terms on the balance.

DEAGAN MARIMBAPHONES

PLAYED WITH EITHER MALLETS OR BOWS

Marimbaphones are for two reasons daily coming into greater use in preference to the Xylophone. While the method of operation is similar to that of the Xylophone, the Marimbaphone is much easier to play as its tones are sufficiently sustained so that rapid execution and fine technique are not so necessary as with the Xylophone. Furthermore, the tone of the Marimbaphone is soft, sweet and mellow, and is consequently to be preferred to that of the Xylophone in many cases. Marimbaphones are played with soft mallets which do not injure the bars, so will last a lifetime. All metal parts are triple nickel plated and highly polished, and all wooden parts are finished in natural wood and highly polished, the same as a piano. The frames on which the bars are mounted are the very finest quarter-sawed white oak, the floor racks of finest seamless steel tubing and are of the slip-joint type, no screws to get lost or out of order. Can be taken down and packed or unpacked and set up in a minute's time.

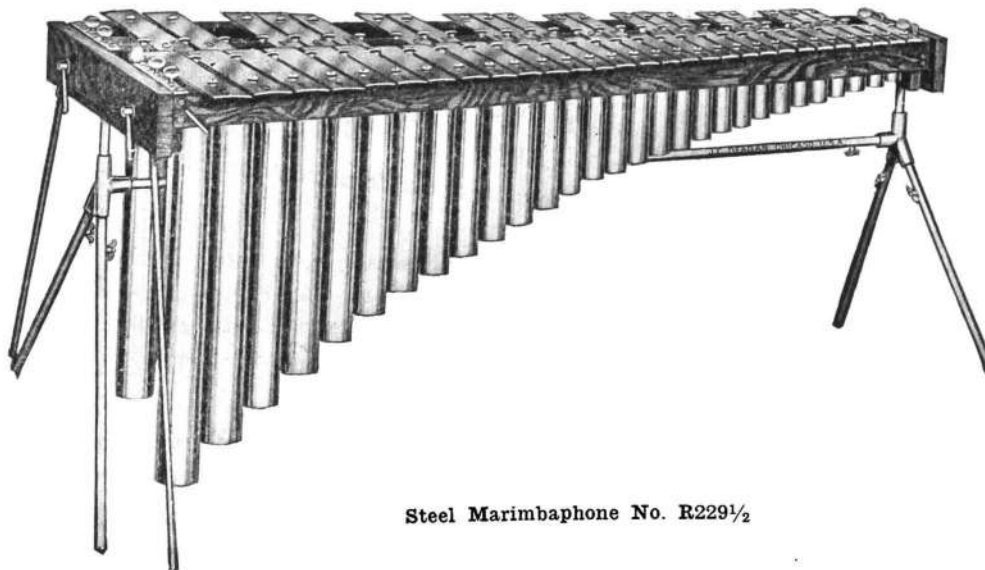

Steel Marimbaphone No. R229¹/₂

Special alloy steel bars, each equipped with a resonator of special design. The bars are set on frames which are in turn mounted on a substantial steel tube floor rack. Played with either bows or mallets, the change from bowing to mallet playing position being accomplished instantaneously by turning bolts conveniently located at the end of the instrument. In the bowing position the bars are turned from horizontal to perpendicular. Played with mallets, the tone is similar to that of the harp, with bows, like that of musical tumblers only much louder. Can be played by from one to four persons. Excellent for orchestra work or for home use. Total length, 57 inches.

No.	Each
R229 ¹ / ₂ —49 bars, 4 octaves, chromatic, C to C, Low Pitch, including 7 pairs assorted mallets	\$210.00

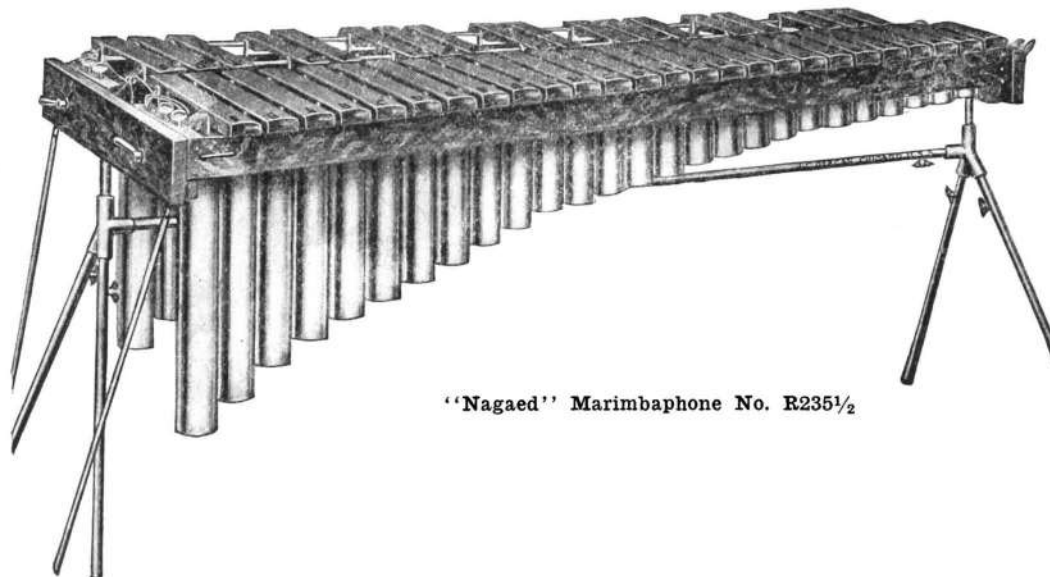

'Nagaed' Marimbaphone No. R235¹/₂

Nagaed wood bars mounted on frames, each bar equipped with a specially designed Deagan Patent Resonator. Played with either mallets or bows, the same as Steel Marimbaphone No. R229¹/₂. The Nagaed Marimbaphone tone is a revelation, being very deep, mellow and melodious. The tones in the lower register have a similarity to a fine tympany and when played with three or more mallets the tone resembles that of a pipe organ. Total length, 68 inches.

No.	Each
R235 ¹ / ₂ —44 bars, 2 x 1 3/8 inches; 3 1/2 octaves, chromatic, F to C, Low Pitch, including 8 pairs assorted mallets.....	\$220.00

The above instruments are made especially to order. Three weeks time required.
Your old Bells or Xylophone taken in part payment if built in Low Pitch. Easy monthly payment terms on the balance.

PROFESSIONAL BAND AND ORCHESTRA BELLS

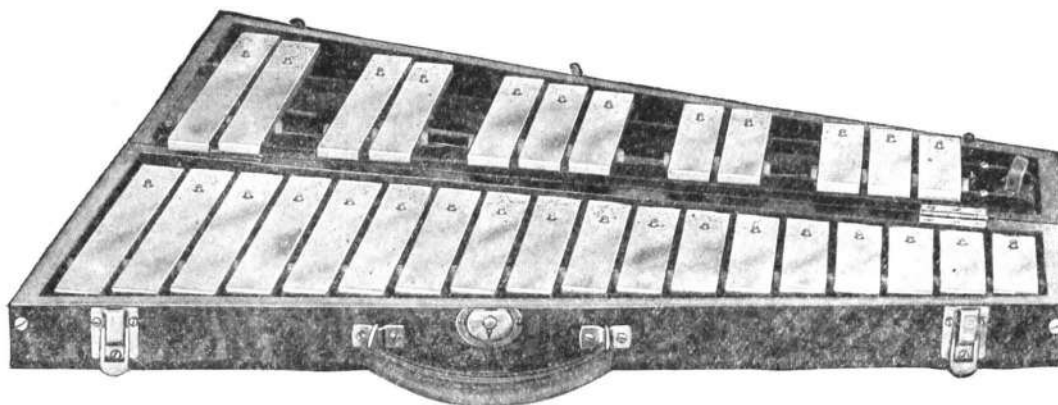

Deagan Special Bells No. R15 $\frac{1}{2}$. Flat Top; Length of Case, 28 $\frac{1}{2}$ Inches

SHERMAN, CLAY & CO. BELLS

These Bells are made especially for us by one of the leading orchestra bell manufacturers of the United States and have been produced for the purpose of meeting the demand for first-class, fine-toned, accurately tuned bells that will answer for exacting professional work and which shall at the same time be cheaper than those bearing the Deagan brand. The market affords no other orchestra bell which begins to compare with these in quality at similar prices. They are cheap only in price, being guaranteed perfect in pitch, accurately tuned, of splendid tone quality and substantial and satisfactory in every respect. Built in Low Pitch, interchangeable to High—an extra bar being provided for transposing.

No. R11 $\frac{1}{2}$ —2 $\frac{1}{2}$ octaves, chromatic, G to C; 30 bars, 1 $\frac{1}{8}$ x $\frac{1}{4}$ inches, triple nickel plated and highly polished. Low pitch, interchangeable to High. In mission-finished quarter-sawed oak case with handle, two heavy trunk fasteners and lock. Two pairs mallets included. \$20.00

DEAGAN SPECIAL BELLS

A first-class bell at a moderate price. The only difference between these Special Bells and the Standard Deagan Bells is that the steel from which the Special Bells are made is not so fine in quality while the tops of the bars are flat instead of convexed. They are mounted in the same cases as the more expensive Deagan Bells, are as finely made and as perfect in their tuning.

No. R13 $\frac{1}{2}$ —2 octaves, chromatic, C to C; 25 bars, $\frac{7}{8}$ x $\frac{3}{8}$ inch; **Low Pitch**; in folding case. Case 18 $\frac{3}{4}$ inches long, net weight 21 lbs., shipping weight 29 lbs. \$22.50
 R14 $\frac{1}{2}$ —2 $\frac{1}{2}$ octaves, chromatic, G to C; 30 bars, $\frac{7}{8}$ x $\frac{3}{8}$ inch; **Low Pitch**; in folding case. Case 21 $\frac{1}{2}$ inches long, net weight 26 lbs., shipping weight 33 $\frac{1}{2}$ lbs. 26.50
 R15 $\frac{1}{2}$ —2 $\frac{1}{2}$ octaves, chromatic, G to C; 30 bars, 1 $\frac{1}{4}$ x $\frac{3}{8}$ inch; **Low Pitch**; in folding case. Case 28 $\frac{1}{2}$ inches long, net weight 37 lbs., shipping weight 48 lbs. 30.00

Equipment with all Deagan Special Bells: 3 pairs Assorted Mallets, Extra Bar to Change Pitch from Low to High, Detachable Music Rack.

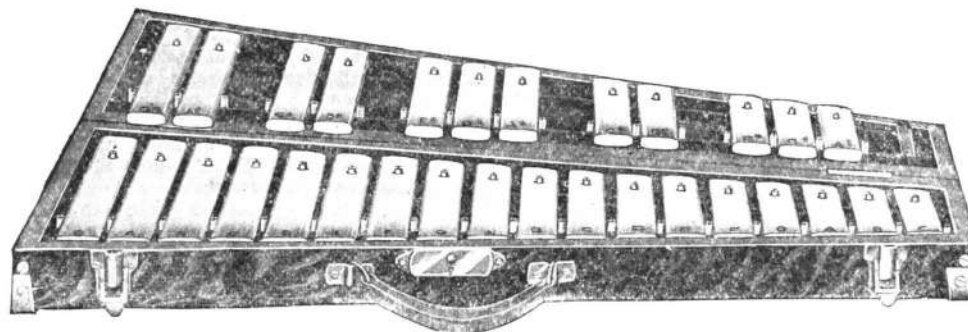

Deagan Round Top Bells No. R24 $\frac{1}{2}$. Length of Case, 28 $\frac{1}{2}$ Inches

DEAGAN ROUND TOP BELLS The Finest Bells Manufactured

Deagan Round Top Bells have the best tone of any bell in the world and are very much easier to play than Flat Top Bells, owing to the fact that the top being slightly convexed, the full tone of the bell is produced whether it is struck at an angle or squarely.

In Flat Top Bells it is necessary to strike the bars absolutely square to produce the full tone. The peculiar shape of the Round Top Bell also eliminates all overtones or counter harmonics—only the pure fundamental tone is heard. Furthermore, as the under side of the Round Top Bells is also convexed, there is less surface in contact with the supporting felt, leaving the bell more free to vibrate, resulting in a richer, better tone, of greater carrying power than that of the Flat Top Bells. The rounded top and upper edges also materially assist the playing of rapid passages.

No. R22 $\frac{1}{2}$ —2 $\frac{1}{2}$ octaves, chromatic, G to C; 30 bars, $\frac{7}{8}$ x $\frac{3}{8}$ inch, in fine oak folding case; **Low Pitch**; length of case 21 $\frac{1}{2}$ inches; net weight 23 $\frac{1}{2}$ lbs., shipping weight 31 lbs. \$35.00
 R23 $\frac{1}{2}$ —3 octaves, chromatic, C to C; 37 bars; 1 x $\frac{7}{8}$ inch, in fine oak folding case; **Low Pitch**; length of case 31 inches; net weight 46 lbs., shipping weight 58 lbs. 44.00
 R24 $\frac{1}{2}$ —2 $\frac{1}{2}$ octaves, chromatic, G to C; 30 bars, 1 $\frac{1}{4}$ x $\frac{3}{8}$ inch, in fine oak folding case; **Low Pitch**; length of case 28 $\frac{1}{2}$ inches; net weight 41 lbs., shipping weight 53 lbs. 46.50

Equipment with all Deagan Round Top Bells: 5 Pairs Assorted Mallets, Extra Bar to Change Pitch from Low to High, Detachable Music Rack, Shoulder Strap that snaps to handle loops for carrying.

DEAGAN PARSIFAL BELLS

For Band and Orchestra Use

Deagan "Round Top Parsifal Bells" are the latest and greatest improvement in Orchestra Bells. They are absolutely without over-tones or counter harmonics. You hear nothing but the pure tone of the Bell—no jingling or disagreeable over-tones. The patent resonator attached to each bar adds greatly to the volume and sweetness of tone. Parsifal Bells are loud enough for the largest band when played with ordinary hammers and when played with soft hammers they are an ideal accompaniment for songs, etc. The cases in which the Bells are mounted are the very finest five-ply veneer quarter-sawed oak, brass-bound and piano finished. The hardware is triple nickel plated.

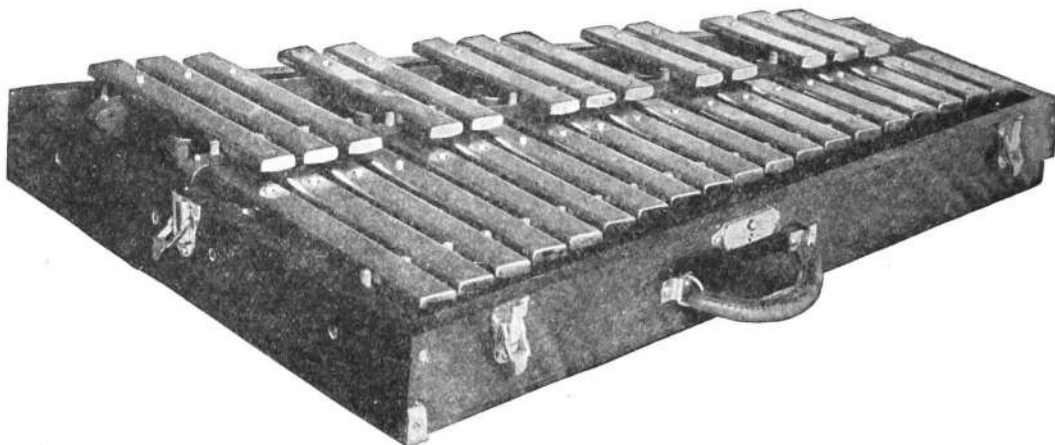

No. R29½—Parsifal Bells. Lid removed ready to play. Length of Case, 32 inches

No. R29½—2½ octaves, chromatic, F to C, 32 bars, 1¼ x 1⅞ inch, with Resonators, Low Pitch, in flat oak case, including 7 pairs assorted mallets, extra bar to change from Low to High Pitch, detachable music rack, shoulder strap that snaps to handle loops.....\$90.00

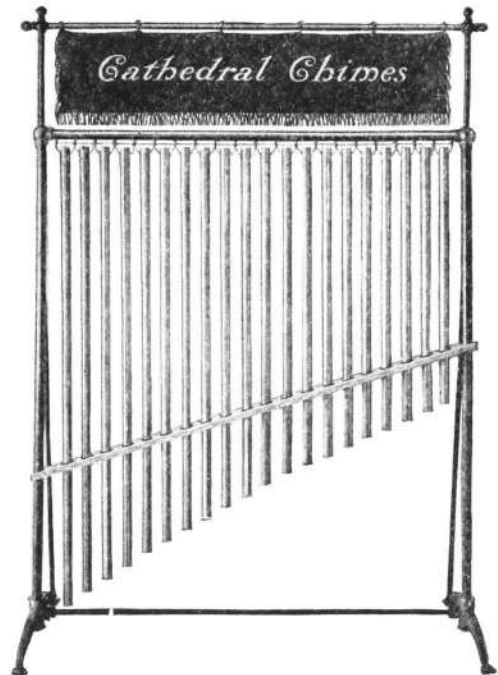

Prices on other sizes and ranges of Chimes quoted upon application.

DEAGAN CATHEDRAL CHIMES

Are a perfect imitation of church chimes. They are made of the choicest bell-metal and are so constructed that the counter harmonics are made to blend with the fundamental tone of the chimes, thus eliminating discords. In all Deagan Chimes the diatonic scale tubes are nickel plated and highly polished, the semi-tones copper plated. This greatly facilitates sight playing. Cathedral Chimes are daily coming into more universal use. Today the instrumentation of a musical organization is incomplete without them. In theatre orchestras and motion picture houses, situations are constantly arising where, if the scene is to be made impressive, they are indispensable.

The rack in which the Deagan Chimes are mounted is of telescopic metal tubing and the joints are machine fitted and so accurately made that the stand is perfectly firm when set up. It is the work of but a moment to set up or take down. No screws or other parts to get lost or out of order. The racks are triple nickel plated and highly polished and in the styles listed below are very low as the Chimes are intended to be played sitting down. A webbing separator through which the lower ends of the Chimes pass, prevents the tubes from swinging when played.

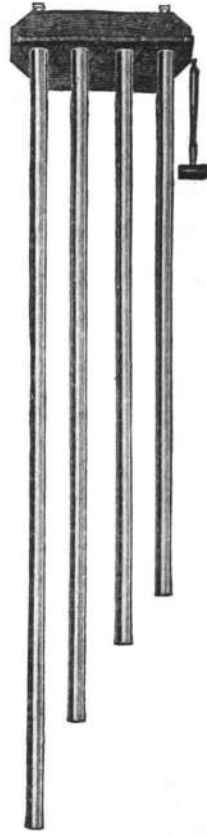

No.	Each
R102—13 Chimes, 1 inch in diameter, 1 octave chromatic, C to C, Low Pitch, including rack and 2 mallets	\$ 70.00
R104—20 Chimes, 1 inch in diameter, 1½ octaves chromatic, A to E, Low Pitch, including rack and 2 mallets	100.00
R203—3 Chimes, 1 inch in diameter, C, F, A, mounted on oak bracket, Low Pitch, mallet included.....	15.00
R205—5 chimes, 1 inch in diameter, C, F, A, C, F, mounted on oak bracket, Low Pitch, mallet included.....	22.50

Deagan's are the world's standard Chimes. The only ones perfectly tuned. The above instruments are made especially to order. Three weeks time required.

ORCHESTRA BELL FLOOR STAND "PERFECTION ECONOMIC" BELL STAND

Will hold any weight bells. Folds in one piece. Height, 18 inches. Finished in white nickel.

No. R13—"Perfection Economic" Bell Stand	Each \$3.00
--	-------------

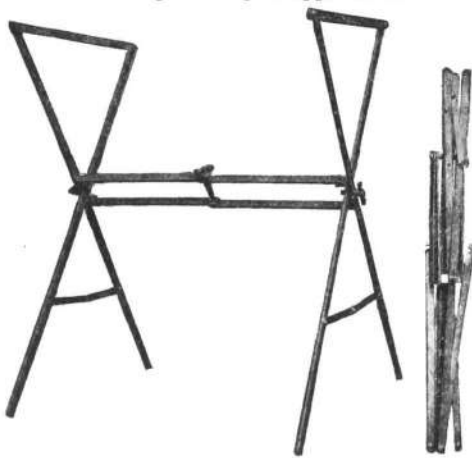

XYLOPHONE AND ORCHESTRA BELL STANDS

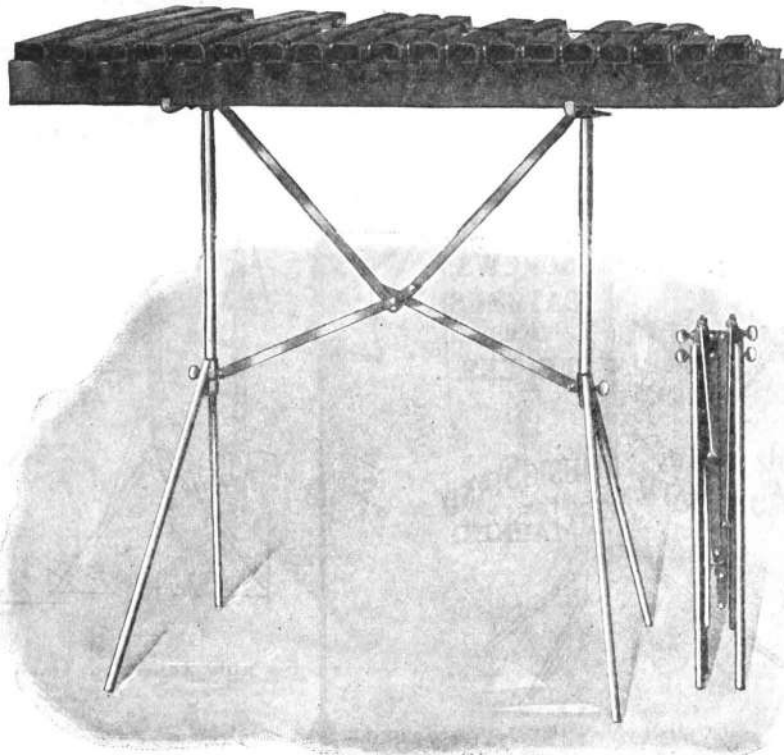

**“PERFECTION” FOLDING AND ADJUSTABLE
XYLOPHONE FLOOR STAND**

Adjustable to any height desired. Folds as shown in cut. Length when folded, 19 inches; weight, all complete, 4½ pounds. Will hold any style Xylophone. Finished in full nickel.

No. Each
R17—“Perfection” Folding and Adjustable Xylophone Floor Stand.....\$7.50

XYLOPHONE, ORCHESTRA BELL AND MARIMBAPHONE MALLETS

Length of handles, 10 inches

No.	Per pair
R2000—Small Bronze Nickel-plated Orchestra Bell Mallet.....	\$0.40
R2001—Large Bronze Nickel-plated Orchestra Bell Mallet.....	.50
R2002—1 inch Soft Rubber Xylophone and Orchestra Bell Mallet.....	.50
R2003—1 inch Half Hard Rubber Xylophone and Orchestra Bell Mallet.....	.50
R2004—1 inch Hard Rubber Xylophone and Orchestra Bell Mallet.....	.50
R2005—1½-inch Soft Rubber Xylophone and Orchestra Bell Mallet.....	.60
R2006—1½-inch Quarter Hard Rubber Xylophone and Orchestra Bell Mallet..	.60
R2007—1½-inch Half Hard Rubber Xylophone and Orchestra Bell Mallet.....	.60
R2008—1½-inch Three-quarter Hard Rubber Xylophone and Orchestra Bell Mallet60
R2009—1½-inch Hard Rubber Xylophone and Orchestra Bell Mallet.....	.60
R2010—1¼-inch Soft Rubber Xylophone and Orchestra Bell Mallet.....	.75
R2011—1¼-inch Hard Rubber Xylophone and Orchestra Bell Mallet.....	.75
R2012—1½-inch Oval Hard Rubber Xylophone and Orchestra Bell Mallet....	.50
R2013—1 inch Pear-shaped Hard Rubber Xylophone and Orchestra Bell Mallet	.60
R2014—Hard Wound Xylophone, Orchestra Bell or Marimba Solo Mallets.....	.50
R2015—Medium Wound Xylophone, Orchestra Bell or Marimba Solo Mallets.	.50
R2016—Soft Wound Xylophone, Orchestra Bell, or Marimba Solo Mallets.....	.50
R2017—Combination Wood and Leather Tip Orchestra Bell and Xylophone Mallet50
R2018—Hard Wound Marimba Accompaniment Mallets.....	.60
R2019—Medium Wound Marimba Accompaniment Mallets.....	.75
R2020—Soft Wound Marimba Accompaniment Mallets90
R2021—Soft Wound Marimba Bass Mallets	1.25
R2022—Soft Wound Marimba Contra Bass Mallets	2.00

Postage 4 cts. per pair.

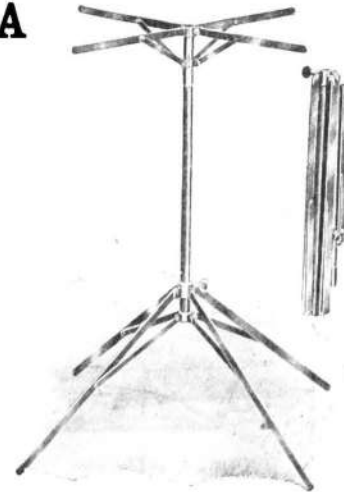

“NEW PERFECTION” BELL STAND

Lightest—Strongest

Weight, 47 ounces. Length folded, 14½ inches. Height adjustable from 18 to 28 inches. Will sustain weight of 200 pounds. Finished in full nickel.

No. Each
R15—“New Perfection” Bell Stand.....\$5.00

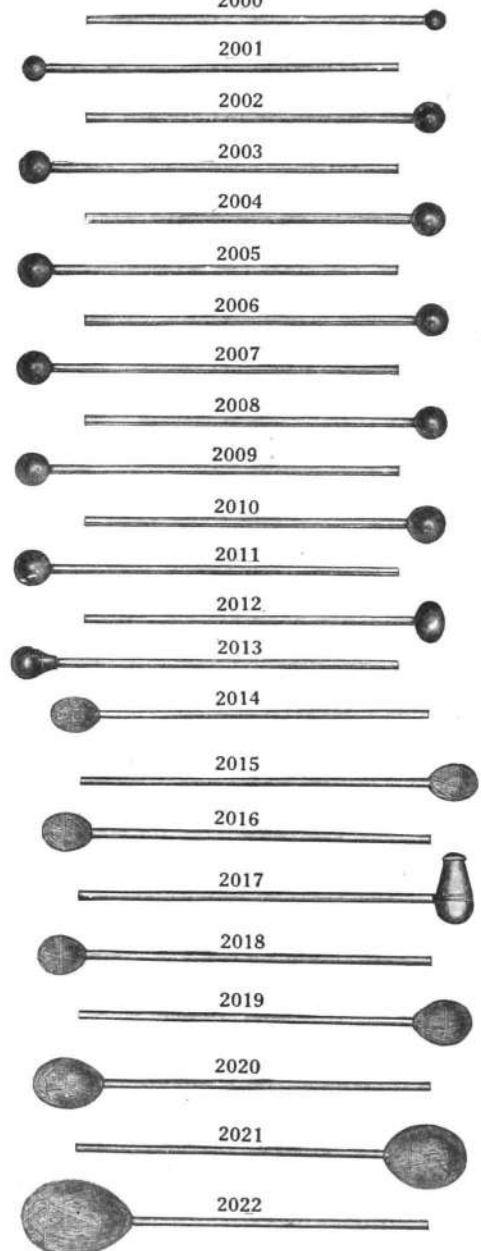

MUSIC STANDS

THE "VICTOR" AUTOMATIC

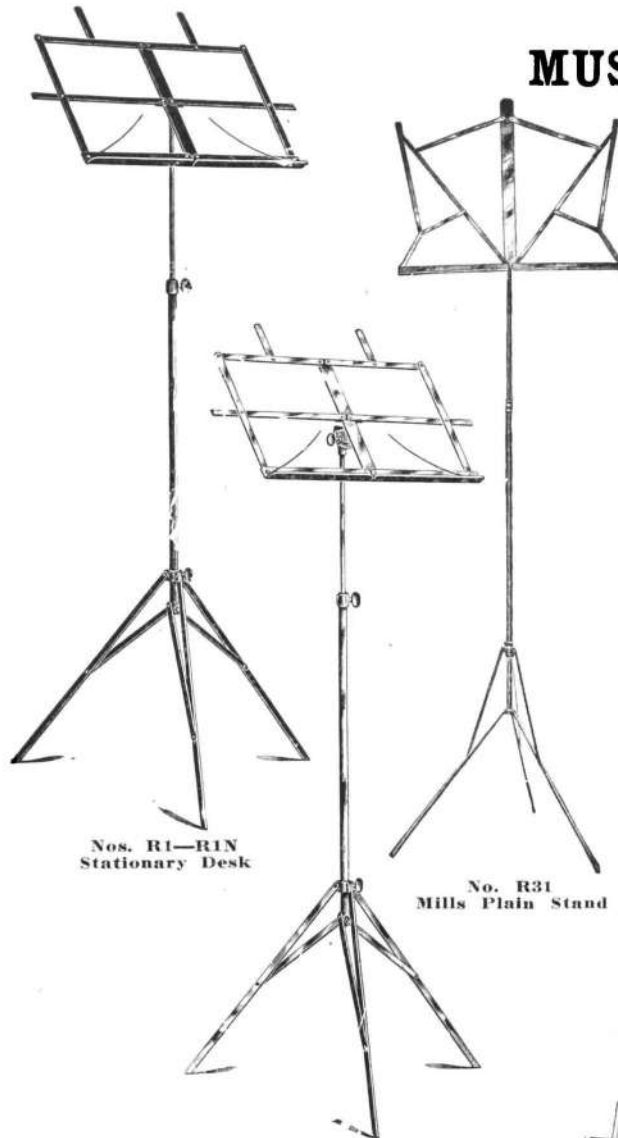

Nos. R1—R1N
Stationary Desk

No. R31
Mills Plain Stand

Nos. R3—R3N
Adjustable Desk



**NO
THUMB
SCREWS,
CATCHES
...OR...
LEVERS.**

The
Only Strictly
AUTOMATIC MUSIC STAND
on the
MARKET

No. R6N
Friction Adjustment

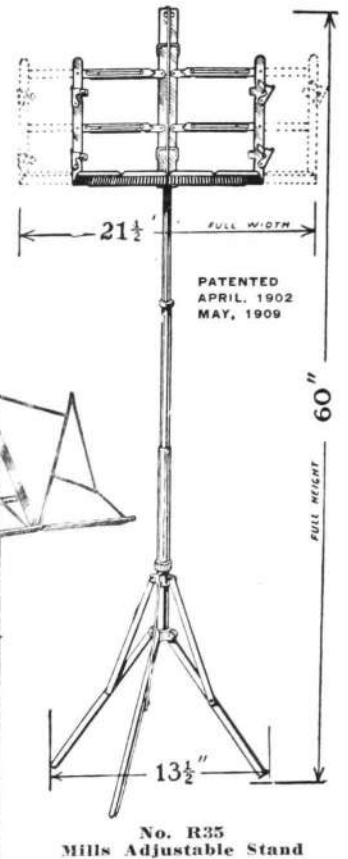

No. R35
Mills Adjustable Stand

Nos. R33—R14
Mills Combination Stands

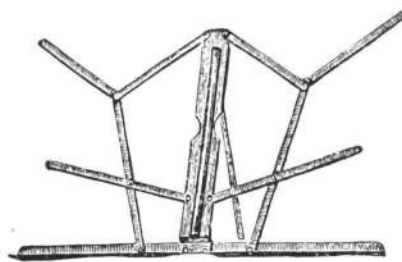

No. RX
Music Desk

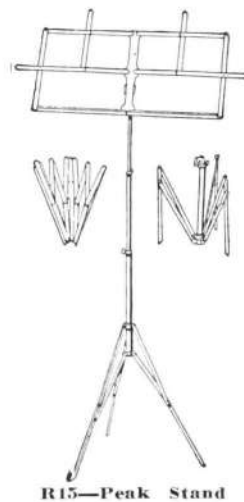

R15—Peak Stand

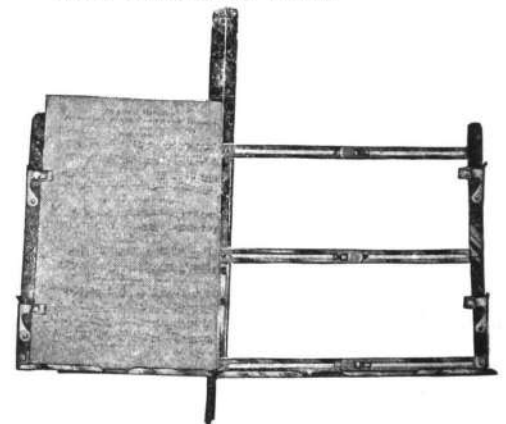

Desk of No. R35 Stand with one side extended. Adjusted to any size in a moment

No.	Description	Each	Not less than 1 doz.
R1	"Victor" Umbrella Stand, black japan finish, solid steel legs and braces.....	\$0.50	\$ 5.50
R1N	Same as No. R1, heavily nickel plated.....	1.00	11.00
R3	"Victor Adjustable," desk adjustable to various angles, black japan finish, well made, quickly adjusted.....	.65	7.00
R3N	Same as No. R3, heavily nickel plated.....	1.25	13.50
R6N	The "Victor Automatic," our highest grade, finely nickel plated, friction adjustment, weight 34 ounces. This stand is opened and closed with more speed than any other stand made, is well braced both top and bottom, will hold all-sized books or sheet music. Very carefully made.....	1.40	15.25

No.	Description	Each	Not less than 1 doz.
R15	Peak Stand, nickel plated, with oxidized legs. Wide desk. For use only when seated. Length, closed, 8 1/2 inches.....	\$2.00
RX	Music Desk, iron, bronzed; folds very compactly. Table or zither desk.....	.35
R31	Mills Plain Top Stand, nickel plated.....	1.50	\$16.50
R33	Mills Combination Stand, desk adjustable to any angle, nickel plated.....	1.75	18.00
R14	Mills Short Telescopic Combination Stand, nickel plated, desk adjustable to any angle. The same as No. R33, but shorter. Designed for portability and closes to a length of 12 inches.....	1.75	19.00
R35	Mills Adjustable Stand, desk adjustable to any size music, nickel plated.....	2.25	24.00

See page 6 for shipping weights

MUSIC STANDS AND CASES

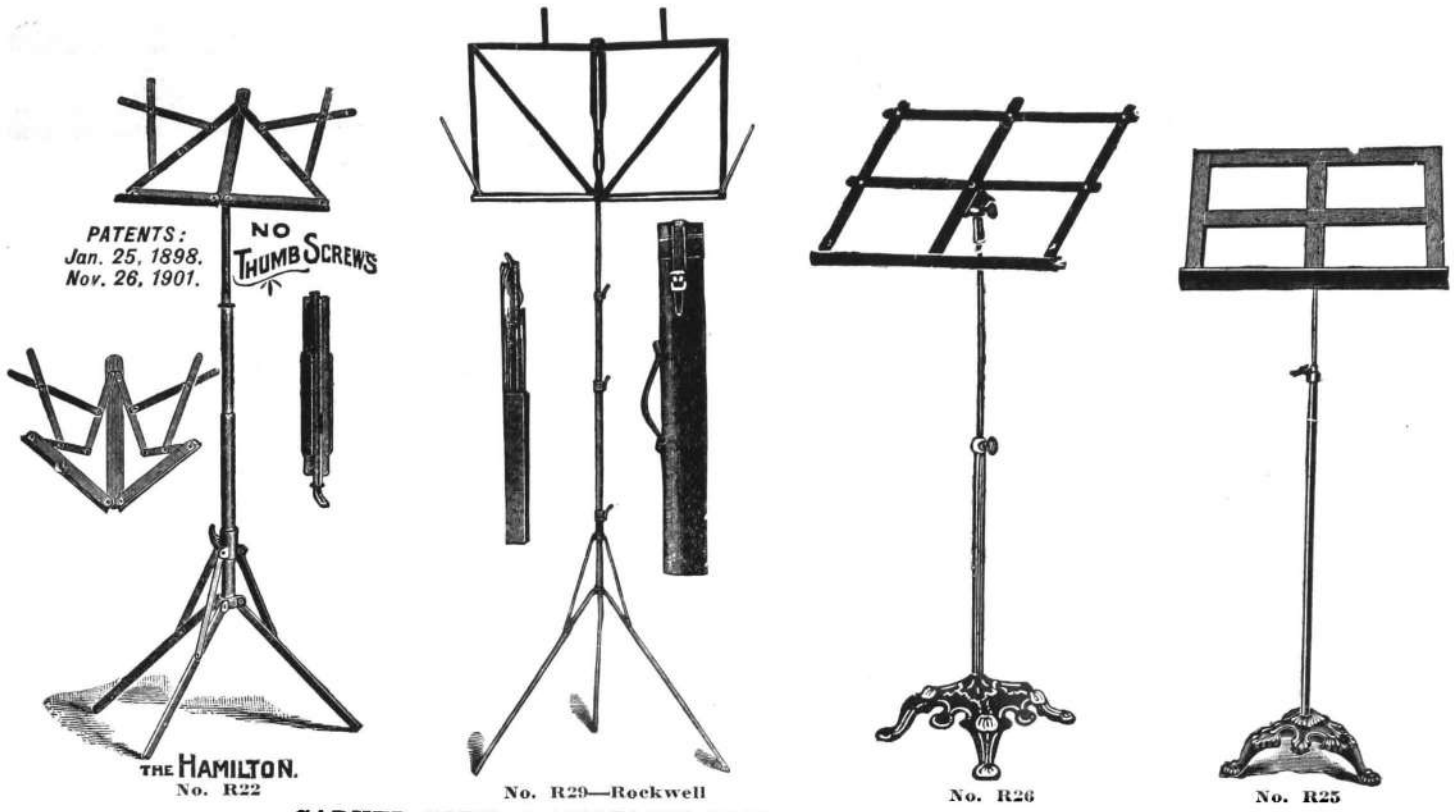

CARVED SOLID MAHOGANY STANDS

MUSIC STAND CASES



No. R 22—"Hamilton," nickel plated, no thumb screws.....	Each	\$1.50	Not less than 1 doz.	\$16.50
R 20—"Rockwell," telescopic, improved and patented clincher joints, length 15 inches, weight 41 ounces.....	Each	1.75		19.00
R 25—"Orchestral," heavy bronzed iron pedestal, oak desk.....	Each	2.75		30.00
R 26—"Orchestral," heavy iron pedestal, japanned steel desk, adjustable desk.....	Each	2.50		27.00
R410—Solid Mahogany, Brass Rod, Stationary Desk.....	Each	9.00		
R420—Solid Mahogany, Brass Rod, same as No. R410, but with desk adjustable to any angle.....	Each	11.50		
R430—Solid Mahogany, Brass Rod, classic style, adjustable desk.....	Each	18.00		
R440—Solid Mahogany, dark finish, brass rod, fancy American style, adjustable desk.....	Each	22.50		

MUSIC STAND CASES

No. R 1—Black or tan smooth grained leather, nicely embossed, leather handle, nickel plated trimmings, rings to attach shoulder straps, for regular stand, size 23x2¼.....	Each	\$1.10	Not less than 1 doz.	\$12.25
R 4—Same as No. R1, for Victor Automatic, Mills, Hamilton or Rockwell stands, size 17x1¾.....	Each	1.00		11.25
R24—Black or tan smooth grained leather, oval, professional model, for Victor Automatic, Mills, Hamilton or Rockwell stands, 17 inches long.....	Each	1.25		13.75

SHOULDER STRAPS FOR MUSIC STAND CASES

No. R 3—Leather, black or russet, with snap at each end and adjustable buckle (postage 4 cents).....	Each	\$0.40	Not less than 1 doz.	\$4.40
--	------	--------	----------------------	--------

MUSIC CLIPS

To fasten music on stand. Hold like a vise and will not wear out

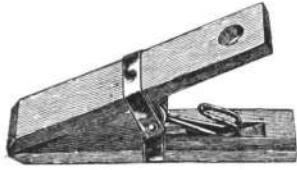

No. R1



No. R4

No.	Description	Each	Dozen	Postage	
				Each	Dozen
R1	Maple brass spring	\$0.10	\$1.00	2 cts.	1 lb. rate
R4	Maple, with long narrow flexible brass rod, fits between staves so music is not obscured	.25	2.50	3 cts.	2 lb. rate
R6	Finley patent clip, made of spring brass, nickel plated, 10 1/2 inches long. No spring to get out of order	.20	2.20	2 cts.	1 lb. rate

MUSIC PAPER

Standard Quality
Large Size, 10 1/4 x 13 1/4

AMERICAN

A Thoroughly Good Paper
Medium Size, 9 1/2 x 12 1/2

No.	Description	Per quire	Postage	No.	Description	Per quire	Postage
R1	12 Staves, upright	.50	2 lb. rate	R13	14 Staves, upright	.40	2 lb. rate
R3	12 Staves, upright, vocal and piano	.50	2 lb. rate	Standard Orchestra Size, 6 3/4 x 10 1/2			
R4	14 Staves, upright	.50	2 lb. rate	R22	12 Staves, upright	.35	1 lb. rate
R6	16 Staves, upright	.50	2 lb. rate				
R20	20 Staves, oblong	.50	2 lb. rate				

IMPORTED—WATERPROOF

Absolutely the finest paper manufactured. Cream Color—Restful to the eyes.

Ink does not run; and it always presents an even hard surface, even when erasures have been made. The pen never catches the fiber of the paper.

Large Size, 10 3/4 x 14

Medium Size, 7 1/2 x 10 3/4

No.	Description	Per quire	Postage	No.	Description	Per quire	Postage
R51	12 Staves, upright	.60	2 lb. rate	R513	14 Staves, upright	.45	1 lb. rate
R53	12 Staves, upright, vocal and piano	.60	2 lb. rate	Standard Orchestra Size, 6 3/4 x 10 3/4			
R54	14 Staves, upright	.60	2 lb. rate	R520	12 Staves, upright	.40	1 lb. rate
R56	16 Staves, upright	.60	2 lb. rate				
R120	20 Staves, oblong, score	.60	2 lb. rate				

Special prices quoted on music paper in ream lots.

MUSIC BLANK BOOKS AND MUSIC CARDS

No.	Description	Each	Per doz.	Postage	
				Each	Dozen
R79	8 Staves, 40 pages, heavy manila cover, oblong, size 6 7/8 x 8 1/4. The "Mozart," especially for schools	\$0.08	\$0.80	3 cts.	3 lb. rate
R83	8 Staves, 24 pages, cloth back, paper sides, flexible cover, oblong, size 7 1/2 x 9 1/2	.10	1.10	4 cts.	3 lb. rate
R80	6 Staves, 40 pages, cloth back, paper sides, flexible cover, oblong, size 7 1/2 x 9 1/2	.15	1.65	1 lb. rate	5 lb. rate
R81	8 Staves, 64 pages, cloth back, paper sides, flexible cover, oblong, size 7 1/2 x 9 1/2	.20	2.20	1 lb. rate	8 lb. rate
R82	8 Staves, 40 pages, cloth back, paper sides, flexible cover, oblong, size 7 1/2 x 9 1/2	.15	1.65	1 lb. rate	5 lb. rate
R94	12 Staves, 80 pages, leather back and corners, black cloth sides, stiff cover, medium, size 9 x 11 3/4	.75	8.00	1 lb. rate	
R99	14 Staves, 80 pages, leather back and corners, black cloth sides, stiff cover, large, size 10 3/4 x 13 1/2	1.00	10.50	2 lb. rate	
R96	9 Staves, 64 pages, glazed cloth, flexible cover, oblong, size 5 1/4 x 6 3/4, for Bands	.15	1.50	1 lb. rate	4 lb. rate
R29	Music cards, size 5 x 7, 8 staves, oblong, for quickstep books, finest imported paper. Ink will not run	1.25			per 100, 1 lb. rate

ADHESIVE PAPER AND LINEN FOR MENDING TORN MUSIC

No.	Description	Each	Per doz.	Postage	
				Each	Dozen
R1	Gummed transparent paper, French, on Spools	\$0.10	\$0.80	1 ct.	1 lb. rate
R2	Gummed transparent linen, "Multum in Parvo," in rolls, 10 yards, 3/4-inch wide	.15	1.50	2 cts.	1 lb. rate
R3	Gummed linen, "Multum in Parvo," in rolls, 10 yards, 2 inches wide, transparent, white, red, blue or green	.50		4 cts.	

HINGED GUMMED LINEN FOR BINDING LOOSE LEAVES IN SHEET MUSIC OR BOOKS

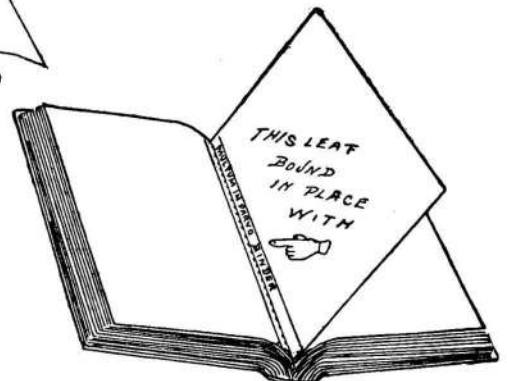
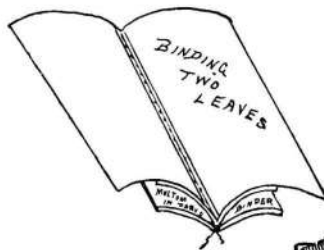

No.	Description	Each	Postage
R4	"Multum in Parvo" Binders, transparent linen, in rolls, 5 yards long, 3/4-inch wide, for binding inside pages in sheet music or in books	\$0.25	2 cts.

BAND STUBS OR FOLIOS

No.		Each	Per dozen, net
R118	"Eagle Folios," 24 muslin stubs, cloth, stiff cover, oblong, size 5½ x 7	\$0.15	\$1.80
R119	"Eagle Folios," 24 muslin stubs, cloth, stiff cover, octavo, size 7½ x 11 inches	.25	1.75
R120	Folio without stubs, cloth, stiff cover, 11 x 14 inches, Sheet Music size, for leaders, teachers, stage performers..	.50	4.25

FALES' AND ELMWOOD ADJUSTABLE BAND FOLIOS

With Adhesive Bindings* to which the music is attached by moisture in an instant. The Fales' Bindings have metal backs and each holds two pieces of music. Each Elmwood Linen Binding holds four pieces of music. The Fales' Bindings are held in the covers by tapes; the Elmwood by metal fasteners.

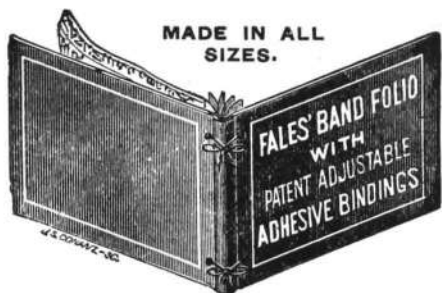

No.		Each	Per dozen, net
R101	Elmwood, Quickstep size, 5½ x 7 inches	\$0.20	\$1.50
R103	Elmwood, Selection size, 7 x 11 inches	.35	3.00

No.		Per dozen	Per gross, net	Postage per doz.
R111	Elmwood extra bindings, Quickstep size, 5½-inch	\$0.15	\$1.20	1 ct.
R113	Elmwood extra bindings, Selection size, 7 -inch	.25	1.80	1 ct.

8 Bindings (capacity 32 pieces of music) are included with each Elmwood Adjustable Folio

No.		Each	Per dozen, net	Postage per doz.
R 1	Fales' Quickstep size, 5½ x 7 inches, with 4½-inch bindings...	\$0.25	\$2.25	1 ct.
R 2	Fales' Selection size, 7½ x 11 inches, with 9 -inch bindings...	.45	3.75	1 ct.
R 2½	Fales' N. Y. Theatre Orchestra size, 9¾ x 12½ inches, with 10½-inch bindings	.60	5.25	1 ct.
R 3	Fales' Concert Edition, sheet music, size 11¼ x 14½ inches, with 12½-inch bindings	.75	6.75	1 ct.

No.		Per dozen	Per gross, net	Postage per doz.
R11	Fales' extra bindings, Quickstep size, 4½-inch	\$0.20	\$1.60	1 ct.
R12	Fales' extra bindings, Selection size, 9 -inch	.30	2.25	2 cts.
R12½	Fales' extra bindings, N. Y. Theatre Orchestra size, 10½-inch	.40	3.00	2 cts.
R13	Fales' extra bindings, Sheet Music size, 12½-inch	.50	3.50	3 cts.

12 Bindings (capacity 24 pieces of music) are included with each Fales' Adjustable Folio

PROGRAM NUMBERS

Numbers and Letters 5 inches high, large enough to be plainly seen in any size hall. 7 x 11 best white cardboard with brass eyelets. 1 TO 20 NUMBERS, EXTRA, WALTZ, TWO-STEP, LANCERS, SCHOTTISCHE, BY REQUEST, THREE-STEP, BARN DANCE, Etc.

No.		Per set
R1	Set complete, including hook for hanging cards on music stand (postage, 1-lb. rate)	\$.60

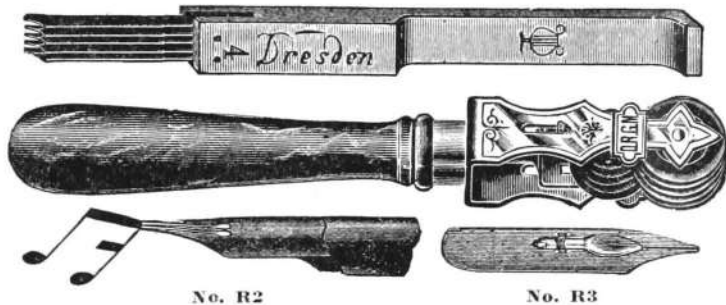

MUSIC RULING AND WRITING PENS

No.		Per doz.	Postage
R2	Steel Pens, for writing music, 3 points...	\$0.25	1 ct.
R3	Steel Pens, Vienna patent, with bulb-shaped ink retainer	.35	1 ct.
R1	Ruling Pens, for ruling staff	.10	1 ct.
R4	Roller Ruling Pens, for ruling staff, with attached pad	1.00	4 cts.

BLACK BOARD LINER

For Drawing Music Staff on School Blackboard

No.		Each
R5	The Rapid Blackboard Staff Liner (postage, 1-lb. rate)	\$.60

OCARINAS

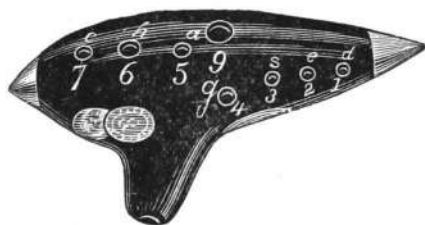

Nos. R1-R21

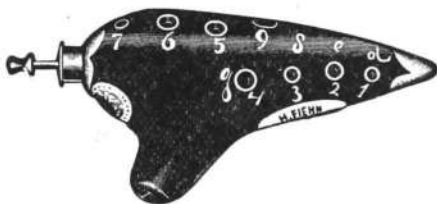

No. R6½

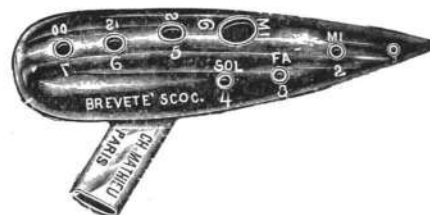

Nos. R101-R106

H. FIEHN, VIENNA

No.		Each	Postage	No.		Each	Postage
R1	Soprano, Key of C	\$0.25	1-lb. rate	R10	Alto, Key of F	\$0.65	2-lb. rate
R2	Soprano, Key of Bb	.25	1-lb. rate	R11½	Alto, Key of Eb	1.00	2-lb. rate
R3	Soprano, Key of G	.30	1-lb. rate	R13	Bass, Key of C	1.25	3-lb. rate
R4	Soprano, Key of F	.30	1-lb. rate	R14	Bass, Key of Bb	1.75	4-lb. rate
R4½	Soprano, Key of Eb	.30	1-lb. rate	R17	Bass, Key of G	2.25	5-lb. rate
R6	Alto, Key of C	.40	1-lb. rate	R18	Contra Bass, Key of F	2.50	6-lb. rate
R6½	Alto, Key of C, with tuning slide, Concert Ocarina	2.00	2-lb. rate	R20	Contra Bass, Key of D	3.25	8-lb. rate
R7	Alto, Key of Bb	.45	2-lb. rate	R21	Contra Bass, Key of C	3.50	9-lb. rate
R9	Alto, Key of G	.50	2-lb. rate				

CH. MATHIEU, PARIS

No.		Each	Postage	No.		Each	Postage
R101	Soprano, Key of C, metal, nickel plated	\$0.25	4 cts.	R105	Baritone, Key of C, metal, nickel plated	\$0.60	1-lb. rate
R102	Soprano, Key of A, metal, nickel plated	.30	1-lb. rate	R106	Baritone, Key of A, metal, nickel plated	.75	1-lb. rate
R103	Alto, Key of F, metal, nickel plated	.40	1-lb. rate	R107	Baritone, Key of C, metal, nickel plated, with tuning slide	1.00	1-lb. rate
R104	Tenor, Key of D, metal, nickel plated	.50	1-lb. rate				

THE "BIG BEN" MUSIC BINDER

A NEW, SIMPLE AND VERY PRACTICAL DEVICE FOR BINDING MUSIC IN BOOK FORM, PERMANENTLY OR TEMPORARILY

THE "BIG BEN" fills a long-felt want for a Music Binder in which the pieces can be quickly inserted or removed, and which at the same time will open perfectly flat on the piano or music rack. It protects and preserves your music in handy form and is really indispensable to the musician and student for keeping each class of music together, etc.

No punching of holes or lacing of string necessary, only the moistening of two gummed linen tie clips which are fastened to the inner sheet or sheets, two penknife slits in the fold of the outer sheet, and the music is ready to insert in the binder, where one motion locks it in place. The illustrations show the extreme simplicity of construction and operation.

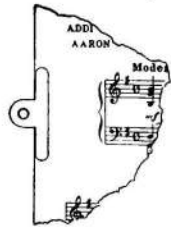

Showing the linen tie clip attached to the center sheet

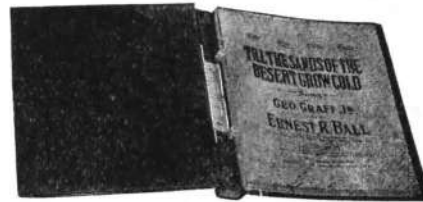

Showing the music all in place with the linen clips strung on the binding rods. The binding rods are fastened into place by merely pushing the locking rod and the book of music is then ready to play from. The Binder opens as flat on the piano desk or music stand as a piece of sheet music.

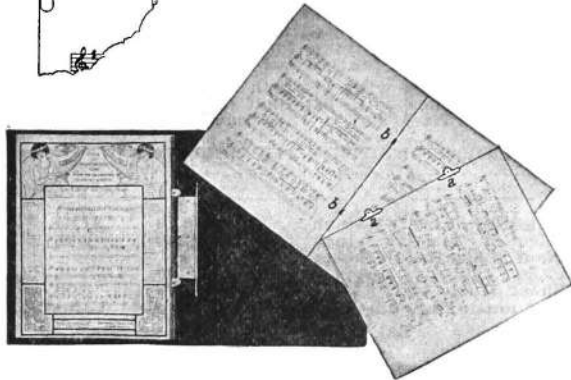

The Binder open with several pieces already in it and one piece spread open ready to be put in. The letters "a" "a" show the linen tie clips attached to the inside sheet ready to insert through the penknife slits "b" "b" in the folded outside sheets.

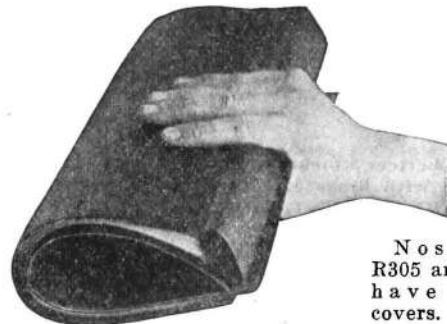

Nos. R301, R305 and R308 have flexible covers.

No.	Standard Music Size: 14 x 11. Capacity: 25 Selections	Each
R301	—Vellum, black, very light weight, semi-flexible covers (for orchestra leaders)	\$1.50
R303	—Library buckram, blue, green or maroon, stiff board covers	2.00
R305	—Imitation leather (black seal grain) flexible covers	2.50
R308	—Genuine leather (black seal grain cowhide), leather lined, flexible covers	5.00
	Extra gummed linen Tie Clips	Per 100, .25

The "Big Ben" Binder can be used year after year by simply taking out the copies one has become tired of and inserting the new ones. Or it can be used as a permanent binding to keep different classes of music together, a valuable feature in the music room.

SPRING BACK MUSIC FOLIOS

FLAT FOLIOS WITH TAPES

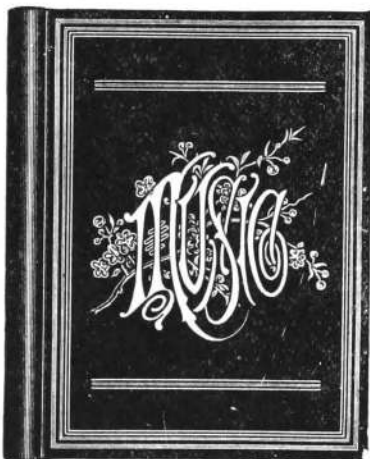

No. R201



No. R227

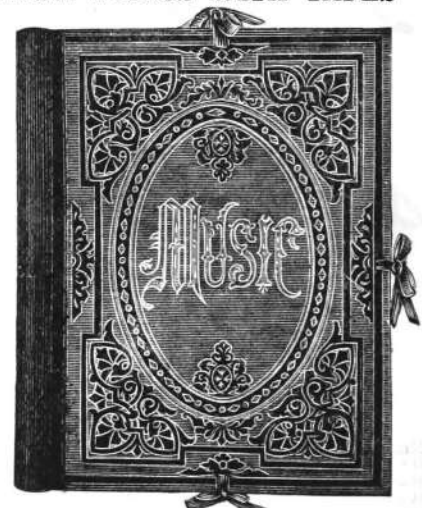

No. R30 1/2

No.		Each
R201	—Cloth back, morocco paper sides, embossed black, "Music" in gilt	\$0.75
R215	—Cloth back, morocco paper sides, embossed gilt flowers and leaves, "Music Folio" in gilt	1.00
R238	—Seal finish leather back and corners, cloth sides, "Music" in gilt and black	1.50
R227	—Imitation alligator back and corners, fancy cloth sides, silver fillets, heavy nickel monogram "Music"	2.50

FLAT FOLIOS—WITH TAPES FOR TYING

No.		Each	Dozen
R30 1/2	—Cloth back, morocco paper sides, front embossed fancy design and "Music" in gilt	\$0.50	\$5.50
R31	—Leather back, morocco paper sides, front embossed fancy design and "Music" in gilt	.75	8.00
R50	—Leather back, morocco cloth sides, black and gilt, with handles	1.00	10.50

MUSIC SATCHELS AND CASES



Nos. R1464, R1466, R1484



No. R1488



No. R1476



No. R1497—Size, 14 $\frac{3}{4}$ x 11 x 2 $\frac{5}{8}$
 No. R1499—Size, 13 x 9 $\frac{1}{2}$ x 2 $\frac{1}{4}$

No.	Each
R1464—Seal grain keratol, lined with moreen and bound with keratol around the edges, leather strap and two leather handles which go around the bottom of the case. Colors, black, brown, wine	\$2.00
R1466—Walrus grain leather, lined with leatherette, leather strap and two leather handles which go around the bottom of the case. Black only	3.50
R1476—Fine quality ooze cowhide, self-lined, with handsomely embossed flap, leather strap and two leather handles which go around the bottom of the case. Colors, brown, gray, orange, tan	5.00
R1484—Smooth calf finished cowhide, self-lined, with leather strap and two leather handles which go around the bottom of the case. Black only	5.00
R1488—Superior quality seal grain leather, leather lined and with turned in edges, leather strap to match, and two leather handles. A substantial and very rich appearing case. Black only	7.50
R1497—Heavy smooth sole leather in black or orange, box shape, lined with flannel, rings for shoulder strap. Suitable for carrying books, periodicals, etc., as well as music. For piano sheet, size 14 $\frac{3}{4}$ x 11 x 2 $\frac{5}{8}$ inches.....	4.00
R1499—Same description as No. R1497, but for orchestra sheet, size 13 x 9 $\frac{1}{2}$ x 2 $\frac{1}{4}$ inches	4.00
R 3—Shoulder strap, black or russet leather with snap at each end and adjustable buckle, for Nos. R1497 and R1499 Music Cases. (Postage, 4 cts.)40

Write for General Catalogue showing our extensive line of Music Rolls, Bags and Folds. Nearly 50 different patterns to choose from.

See page 6 for Shipping Weights

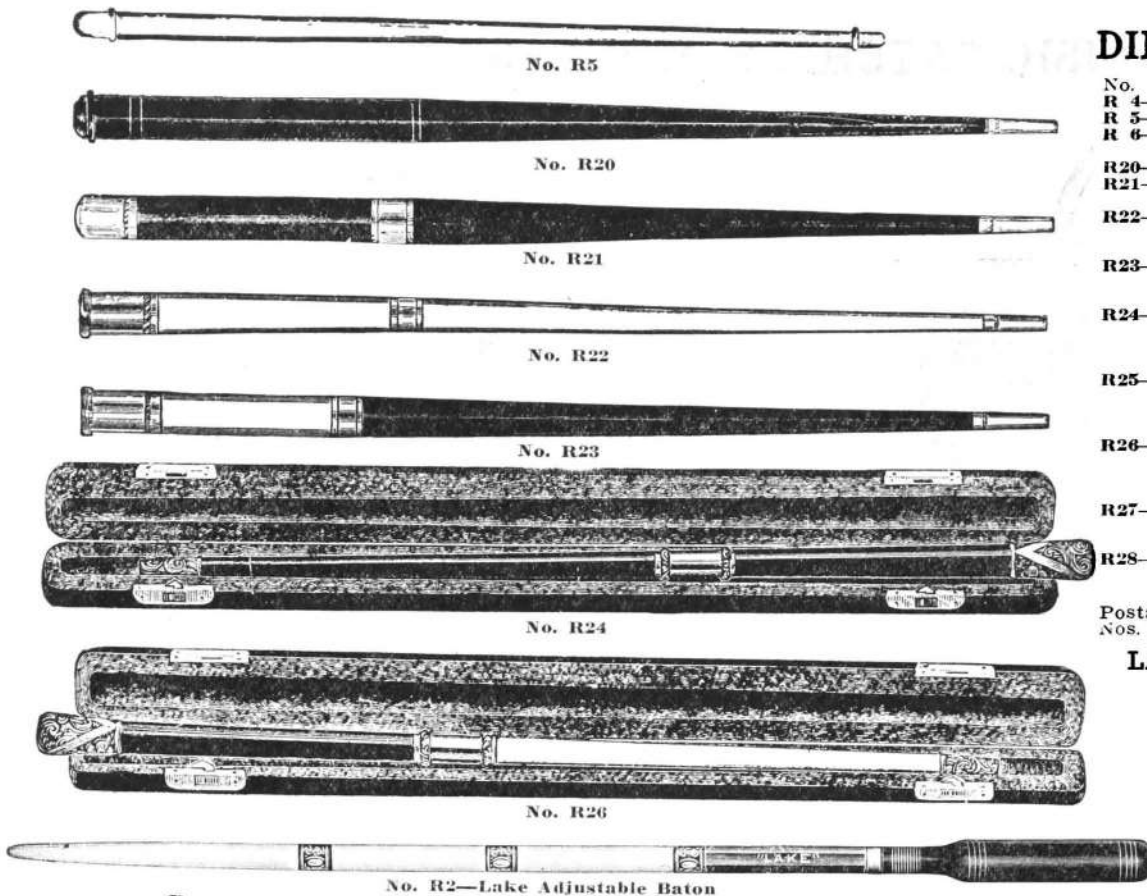

DIRECTORS' BATONS

No.	Each
R 4—White holly, plain.....	\$0.20
R 5—White holly, tapering40
R 6—Ebony, straight, German silver bands, short models....	.60
R20—Ebony, tapered, nickel tip..	1.00
R21—Ebony, tapered, two parts, nickel tips and ring.....	1.50
R22—White holly, tapered, two parts, German silver tips and ring	2.50
R23—Ebony, ivory handle, tapered, German silver tips and ring	5.00
R24—Ebony, highly polished, engraved pure silver mountings, in silk plush lined leather case	10.00
R25—Ebony, highly polished, ivory handle, engraved pure silver mountings, in silk plush lined leather case.....	12.50
R26—Ivory, highly polished, ebony handle, engraved pure silver mountings, in silk plush lined leather case.....	15.00
R27—Ivory, engraved pure silver mountings, in silk plush lined leather case	20.00
R28—Ivory, engraved rolled gold mountings, in silk plush lined leather case	25.00

Postage: Nos. R4 and R5, 4 cts. each; Nos. R6 to R28, 1-lb. rate.

LAKE ADJUSTABLE BATON

THE MOST CONVENIENT, PRACTICAL AND PERFECTLY BALANCED BATON MADE

In five joints, which are quickly unscrewed or readjusted. Full length, 18 inches, or by eliminating joints, they can be made either 15 or 12 inches. Can be carried in vest pocket. Finest quality hard rubber and ivory, superbly finished and gold mounted. Each in neat box.

No.	Each	Postage
R1—Black hard rubber, with white ivory tip, 4 gold bands.....	\$4.00	1-lb. rate
R2—Artist's Favorite, 2 joints of hard rubber, 3 of white ivory, extra mounted	4.50	1-lb. rate
R3—Patriotic, red, white and blue ivory, very handsome.....	5.50	1-lb. rate
R4—Combination Artist's Favorite and Patriotic. This consists of No. R2 with the red, white and blue ivory joints of No. R3. Cost of Nos. R2 and R3, purchased separately, \$10.00. Special price for Combination	6.50	1-lb. rate

No. R4 Combination is Endorsed by Santleman, Director of the U. S. Marine Band

TUNING FORKS AND TUNING PIPES

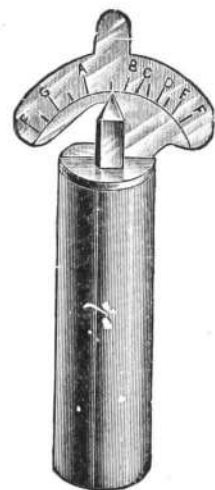

Nos. R9, R9 1/2

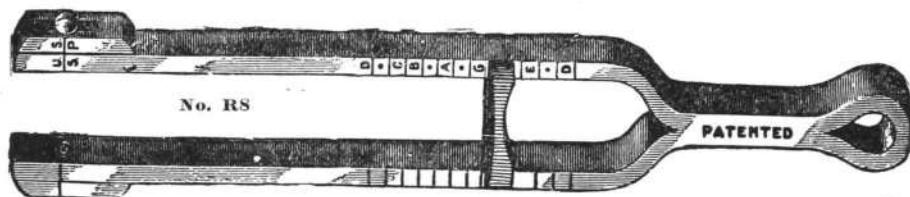

No. R8

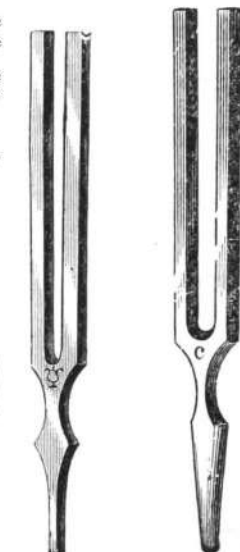

Nos. R0—R10 1/2 Nos. R1—R6 1/2



No. R16 1/2



Nos. R6, R6 1/2, R7, R7 1/2, R8, R8 1/2

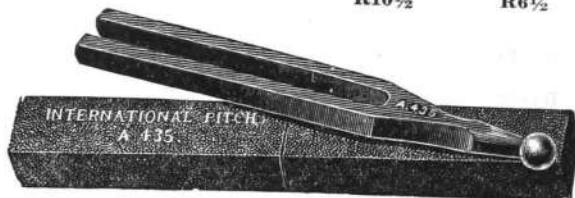

Nos. R12, R13

TUNING FORKS

High Pitch	Low Pitch	No.	Each	Postage
R0	R10	—A, blued steel	\$0.10	1 ct.
R0 1/2	R10 1/2	—C, blued steel10	1 ct.
R1	R 1 1/2	—A, best steel, good quality15	2 cts.
R2	R 2 1/2	—C, best steel, good quality15	2 cts.
R5	R 5 1/2	—A, blued steel, extra size and quality35	2 cts.
R6	R 6 1/2	—C, blued steel, extra size and quality35	2 cts.
	R12	—A, blued steel, fine, in box60	3 cts.
	R13	—C, blued steel, fine, in box60	3 cts.
	R 8	—Chromatic, steel, nickel plated	1.25	4 cts.

TUNING PIPES

High Pitch	Low Pitch	No.	Each	Postage
R6	R 6 1/2	—A, nickel plated, in nickel box	\$0.10	2 cts.
R7	R 7 1/2	—C, nickel plated, in nickel box10	2 cts.
R8	R 8 1/2	—A and C, nickel plated, in nickel box15	2 cts.
	R16 1/2	—Chromatic, nickel covers, Congdon pattern.....	.30	3 cts.
R9	R 9 1/2	—Chromatic scale, nickel plated75	2 cts.

ZOBOS AND SONOPHONES

BURLESQUE BAND INSTRUMENTS

Played by the Voice

Each in a Box With Directions

No Instruction Necessary

SOLID METAL, BRASS FINISH (except No. R59 Zobo-phone), HIGHLY POLISHED

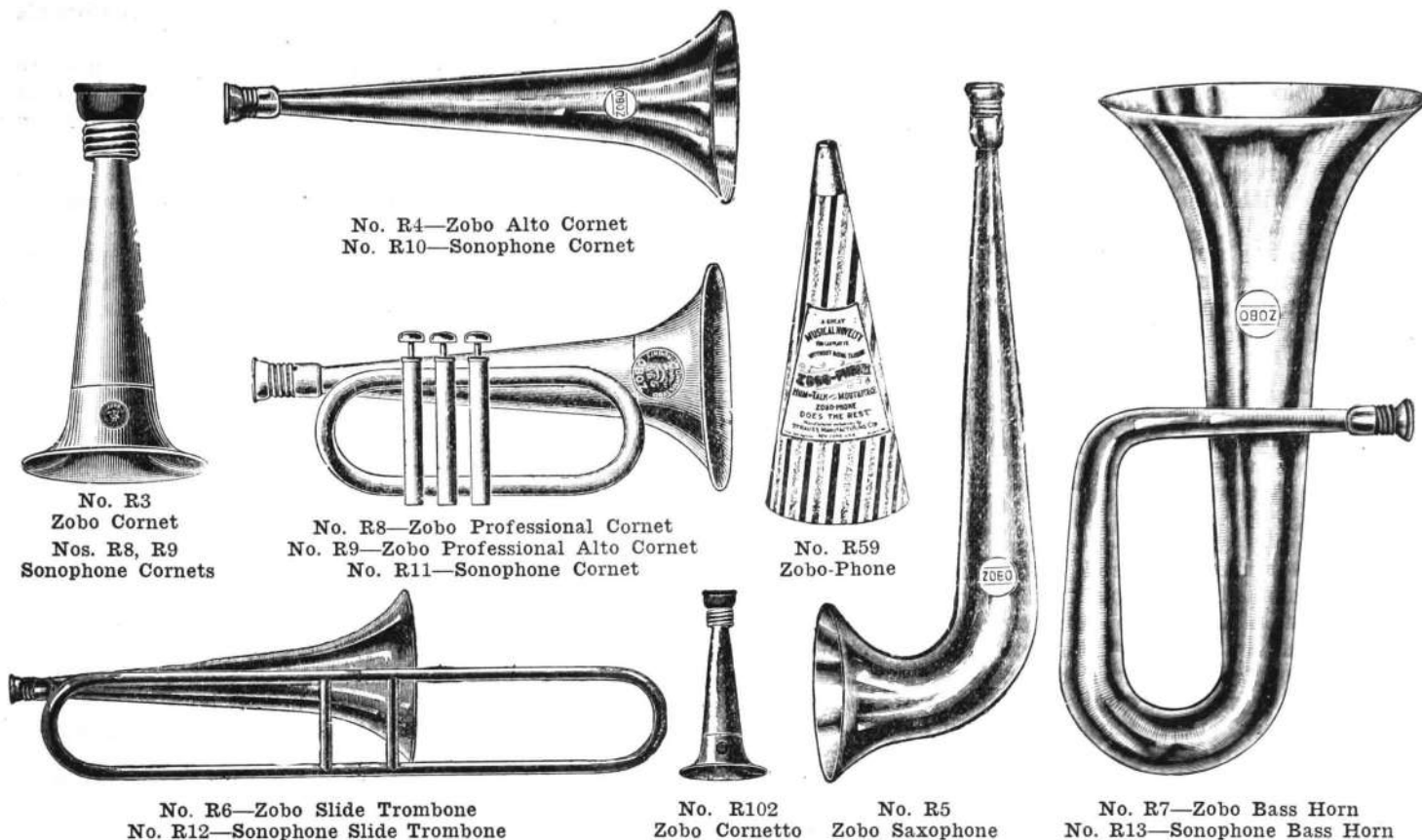

No. R4—Zobo Alto Cornet
No. R10—Sonophone Cornet

No. R3
Zobo Cornet
Nos. R8, R9
Sonophone Cornets

No. R8—Zobo Professional Cornet
No. R9—Zobo Professional Alto Cornet
No. R11—Sonophone Cornet

No. R59
Zobo-Phone

No. R6—Zobo Slide Trombone
No. R12—Sonophone Slide Trombone

No. R102
Zobo Cornetto No. R5
Zobo Saxophone

No. R7—Zobo Bass Horn
No. R13—Sonophone Bass Horn

ZOBOS

No.	Each
R 59—Zobo-phone, extra heavy cardboard, covered with red, white and blue striped paper; smooth finish, nickel-plated safety metal mouthpiece	\$0.05
R102—Zobo Cornetto, solid metal, brass finish.	.25
R 3—Zobo Cornet, solid metal, brass finish. Plays first part or highest voice (Soprano or Tenor) in Zobo band, orchestra, quartet or club	1.00
R 4—Zobo Alto Cornet, solid metal, brass finish. Plays second part (Alto or Second Tenor)	1.25
R 5—Zobo Saxophone, solid metal, brass finish. Plays first bass in quartet or Zobo band.	1.75
R 6—Zobo Slide Trombone with working slide, solid metal, brass finish. Plays baritone in quartet or Zobo band.	4.00
R 7—Zobo Bass Horn, solid metal, brass finish. For bass voice in solo, quartet or band.	4.00
R 8—Zobo Professional Cornet, solid metal, brass finish. For solo or leading voice in quartet or band. Has three working plungers—looks like genuine cornet	2.00
R 9—Zobo Professional Alto Cornet, same as No. R8, but larger. Plays second part, alto or second tenor in quartet or band.	2.50
R205—Zobo Repair Package. Box containing 3 Zobo mouthpiece buttons, each with vibrator attached. (Postage, 1 ct.) Per box	.05

DIMENSIONS OF ZOBOS

R 59—Zobo-phone, 7 inches long.	R6—Zobo Slide Trombone, 27 inches long, 7-inch bell.
R102—Zobo Cornetto, 5 inches long, 2½-inch bell.	34 inches long with slide fully extended.
R 3—Zobo Cornet, 11 inches long, 5½-inch bell.	R7—Zobo Bass Horn, 21 inches high, 9-inch bell.
R 4—Zobo Alto Cornet, 14 inches long, 6-inch bell.	R8—Zobo Professional Cornet, 11 inches long, 5½-inch bell.
R 5—Zobo Saxophone, 21 inches long, 6-inch bell.	R9—Zobo Professional Alto Cornet, 14 inches long, 6-inch bell.

SONOPHONES

No.	Each
R 8—Sonophone Cornet, solid metal, brass finish, 7½ inches long, 3¾-inch bell	\$0.25
R 9—Sonophone Cornet, solid metal, brass finish, 9 inches long, 4¾-inch bell	.50
R10—Sonophone Cornet, solid metal, brass finish, 12 inches long, 6 inch bell	.75
R11—Sonophone Professional Cornet, solid metal, brass finish, 9 inches long, 4¾-inch bell	1.00
R12—Sonophone Slide Trombone, with working slide, solid metal, brass finish, 12 inches long, 4¾-inch bell, slide 24 inches open, 20 inches closed	1.50
R13—Sonophone Bass Horn, solid metal, brass finish, 12 inches high, 6-inch bell	2.00
R15—Sonophone Repair Package, containing 12 vibrators. (Postage, 1 ct.)	Per package, .05

See page 6 for Shipping Weights

SHERMAN, CLAY & CO.'S REPAIR DEPARTMENT

Our equipment and facilities for the repair of musical instruments of every description are greatly superior to those of any other house on the Pacific Coast, and our Band Instrument shops are our special pride. They are under the supervision of a very competent maker who has been in our employ for a number of years and who received his training in the large brass band instrument factories of Germany and Bohemia. We are consequently in a position to guarantee artistic and thoroughly satisfactory workmanship while our charges are as reasonable as they can be made for first-class work.

When sending horns to us for repairs, be explicit as to the work that is to be done and be careful also to mark the box or package plainly with your name and address. Our repair business is large, many instruments being received daily, and even though a letter may be written us at the same time, it is not always possible to identify instruments unless your name is on the package. Send only the bare instrument, without mouthpieces, set pieces, crooks, etc., as they are unnecessary (unless work is to be done upon them), and are liable to be lost, mixed with others or overlooked when the horn is returned, occasioning inconvenience and perhaps unnecessary expense.

Our abilities and facilities cover practically everything in the line of band and orchestra instrument repairing, adjusting and remodeling. We make crooks, set pieces, valve caps, finger buttons, water keys, new valves of every character and design; remove leaks, take out dents, repolish and replate, repad and readjust clarinets, flutes, piccolos, saxophones—in short, everything in the way of refitting and conditioning.

ESTIMATES

It is difficult to even approximate the cost of repairs without examining an instrument, but if you will send it to us, we will immediately upon its receipt, tell you the exact cost and then await your instructions before proceeding with the work.

SECOND HAND INSTRUMENTS

Our assortment of used band instruments is always quite an extensive one and as it is of course constantly changing, monthly bulletins are issued. If interested, write for our latest list. While as a rule the purchase of a new instrument is to be recommended in preference to an old one, we are at all times able to offer used standard grade instruments at most attractive reductions on the new prices and as all such horns are placed in as perfect condition as possible before being sold, from the standpoint of economy they are desirable. A high grade instrument that has been carefully used for a reasonable length of time is frequently a much better purchase than a cheap new one. Used horns sent anywhere on 3 days' trial, all transportation charges at customer's expense. Remittance to cover these charges must accompany the order. Used instruments priced at \$20.00 upward sold on monthly payments at an increase in the price of 5 per cent. Terms, one-quarter cash down, the balance in 6 monthly payments if under \$35.00; 7 payments if the amount is between \$35.00 and \$50.00; 8 payments if over \$50.00. As a rule we are unable to accept old instruments in part payment for used instruments. We price such horns at exactly what we allow for them, plus only the repair cost and the advertising and selling expense, being content with the profit we have made on the new instrument against which the old one was received. Inasmuch, therefore, as we sell used instruments practically at cost it is obvious that we must receive the cash for them.

BAND INSTRUMENT PLATING

Our facilities for plating all kinds of brass instruments are the best. All our plating is the best triple plate and is guaranteed to be such, and superior to that commonly furnished by other dealers. None but skilled workmen are employed in this work.

Instrument	Nickel Plating	Triple Silver Plating Satin Finish	Triple Silver Plating Sand Blast or Burnished Finish	Triple Silver Plating Sand Blast or Burnished Finish With Burnished Gold Bell
Cornets, Eb, Bb or C.....	\$2.00	\$6.50	\$8.00	\$11.00
Altos, any pattern.....	3.50	8.50	11.00	15.00
Mellophones or Concert Horns.....	4.50	10.00	12.50	17.50
Alto Valve Trombones.....	3.50	8.50	11.00	15.00
Tenor Valve Trombones.....	5.00	11.00	14.00	18.00
Tenor Slide Trombones.....	3.00	7.50	10.00	14.00
Tenors, any pattern.....	4.50	10.00	12.50	17.50
Baritones, any pattern.....	5.00	12.50	16.50	21.50
Bb Basses.....	6.00	17.50	22.50	28.50
Eb Basses, medium size.....	7.50	20.00	26.00	34.00
Eb Basses, large size.....	10.00	22.50	28.50	37.00
Eb Helicon Basses, medium size.....	7.50	20.00	26.00	34.00
Eb Helicon Basses, large size.....	10.00	22.50	28.50	37.00
BBb Basses.....	12.50	25.00	32.50	45.00
Bugles and Trumpets.....	1.25	3.50	4.50	7.00
Soprano Saxophones, straight shape.....			17.50	21.00
Alto Saxophone (also Alto shape Soprano Saxophone).....			21.00	25.25
Tenor Saxophones.....			22.50	27.50
Baritone Saxophones.....			27.50	33.00

NOTE—The prices quoted above are for new instruments only. A reasonable charge is made covering no more than the actual time used to put old or used instruments in condition for plating. Estimates for any kind of plating on any kind of instrument furnished upon request.

WE CARRY THE LARGEST AND MOST COMPLETE STOCK OF BAND AND ORCHESTRA MUSIC ON THE PACIFIC COAST

A postal brings by return mail sample cornet or first violin parts to all the standard and popular music of the day, including hundreds of new issues.

A COMPLETE LINE OF INSTRUCTORS FOR ALL INSTRUMENTS

Your particular attention is called to the following list of Orchestra Collections which can be used with any combination of instruments from Violin and Piano up.

<p>“Gems of the Ball Room,” Nos. 1 to 10. “Beauties of the Ball Room,” Nos. 1 to 3. “Echoes of the Ball Room,” Nos. 1 to 4. “Pride of the Ball Room,” Nos. 1 to 3. “Imperial Orchestra Folio.” “Bay State Dance Collection.” “Root’s Beginners’ Orchestra.”</p>	<p>“Root’s Concert and Parlor Gems.” “Angelus Collection for Orchestra.” “Jacobs’ Grand Orchestra Folio,” Nos. 1, 2, 3 and 4. “Peerless Dance Folio,” Nos. 1 to 6. “Gems from the Opera.”</p>	<p>Southwell’s “Parlor,” “Model,” “Banner,” “Crown” and “Premium” Collections. “Social Dance Album.” “Jewels of the Ball Room.” “Gems of Sacred Melody.” “Gems of Gospel Hymns.”</p>
---	---	--

THE FOLLOWING ARE PARTICULARLY DESIRABLE FOR PROFESSIONAL USE, BEING ALL STANDARD ARRANGEMENTS

“Standard March Folio.”
 “Album of Waltzes,” Vols. I, II and III.

Prices: Small Orchestra (11 parts and Piano), \$3.25; Full Orchestra and Piano, \$4.50; Piano part, \$0.50; all other single parts, \$0.30

“Album of Overtures,” Vols. I and II.
 “Concert Folio,” Vols. I and II.
 “Album of Operatic Selections.”

Prices: Small Orchestra (11 parts and Piano), \$5.00; Full Orchestra and Piano, \$7.00; Piano part, \$0.75; all other single parts, \$0.50

“Favorite Concert Album.”

Prices: 10 parts, \$3.25; 14 parts, \$4.50; Full Orchestra, \$5.50; Piano part, \$0.60 extra; all other single parts, \$0.40. There is also an Organ part with this Album; price, \$0.40

We also carry a large stock of Band Books. The titles of the most popular numbers are given below. Samples sent for selection

CARL FISCHER’S

“Olympic,” “Monarch,” “Majestic.”
 “Elite,” “20th Century,” “Maseot.”
 “Album of 38 National Anthems,” etc.
 “Airs of All Nations,” “Memorial.”
 “Leader’s Delight.”
 “Album of Favorite Waltzes.”
 “Operatic Band Book.”
 “Encore Band Book.”
 “R. B. H. Band Book.”

GEORGE SOUTHWELL’S

“New Beginner’s,” “Delight,”
 “Royal,” “Next,” “Standard.”
 “Suitall,” “Medley.”

JOHN CHURCH CO.’S

“Triumph,” “Ideal,” “U. T. D.”
 “Veribest,” “Verifirst,” “Sousa.”

E. T. ROOT & SONS’

“Professional,” “Gem.”

OLIVER DITSON CO.’S

“Leader’s Joy,” “Constellation.”

MISCELLANEOUS

“Dress Parade,” “Unique.”
 “Hall’s Marches.”
 “Jenkins Advanced,” “32 War Songs.”

The following are for new bands, just starting in and are indispensable, having scales and exercises, for concerted playing:

“Great Prize Amateur”	“First Grade”	“American Band Instructor”
“Jenkin’s Beginner’s”	“Ideal Brass Band School”	“Marsh’s Beginner’s”

We will gladly send the First Violin part of any of the above Orchestra Books, or the Solo B_b Cornet part of Band Books for inspection.

THE PACIFIC COAST HEADQUARTERS

OF THE CELEBRATED

Holton Band Instruments

Write for Special Catalogue

ALSO COAST DISTRIBUTORS OF

The Renowned
Moya Solo Violins
"With the Golden Voice"

Arnold Voigt
Artist Violins

Ernst Heinrich Roth
Artist Copy Violins

Neuner & Hornsteiner
Violins, Cellos and Double
Basses

Matthias Albani
Artist Violins

William C. Stahl
Flat Back Mandolins
and Mandolas

Columbia
Guitars and Mandolins

Washburn
Guitars, Banjos, Mandolins
and Banjo-Mandolins

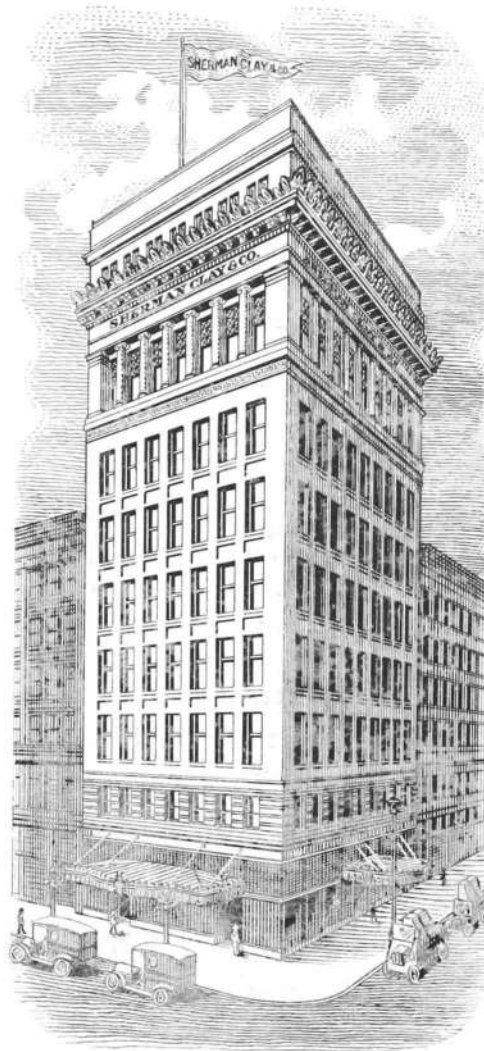

Sherman, Clay & Co.'s magnificent eleven story and basement building, devoted entirely and solely to musical instruments and music

Victrolas
and Victor Talking Machines

**Steinway and
Weber Pianos**
Pianos of all Grades

Pianolas

Aeolian Player Pianos

Aeolian Pipe Organs

Orchestrelles

Complete Catalogues of
Fischer, Church and Ditson
Publications for Band and
Orchestra

**All Popular Sheet and
Band Music**

Sherman, Clay & Co.

KEARNY AND SUTTER STREETS

SAN FRANCISCO, CAL.